



ATO-LCDA630



Servo Driver User Manual





Safety precautions (please read carefully before use)





When receiving inspection, installation, wiring, operation, maintenance and inspection, you should pay attention to the following safety precautions at all times:

Regarding ignoring the contents of the manual and using this product incorrectly, the degree of harm and damage that may be caused is distinguished and explained as shown in the following table.

 Danger	This mark indicates the content of “accidents that may cause injury or property damage”
 Notes	This mark indicates the content of “accidents that may cause injury or property damage”



Use the following graphic signs to explain the matters that should be observed:

	This graphic shows the contents of the prohibited items.
	This graphic shows the "mandatory" content that must be implemented.

 Danger		
About installation and wiring		
	Never connect the motor directly to a commercial power source.	Otherwise, it may cause fire and malfunction.
	Do not place flammable materials around the motor and driver.	Otherwise, it may cause a fire accident.
	The drive must be protected by an outer box. When installing the protective outer box, the outer box wall, other Keep the distance specified in the instruction manual between the machine and the drive.	Otherwise, it may cause electric shock, fire, and malfunction
	It should be installed in a place with less dust and no contact with water, oil, etc.	Otherwise, it may cause a fire accident
	The motor and driver are installed on non-combustible materials such as metal.	Otherwise, it may cause electric shock.
	Be sure to have a professional electrician perform the wiring work.	Otherwise, it may cause electric shock.
	The FG terminal of the motor and driver must be grounded.	Otherwise, it may cause electric shock, injury malfunction, or damage.
	The upper circuit breaker must be cut off in advance and the correct wiring must be performed.	Otherwise, it may cause a fire accident
	The cable should be properly connected and the energized parts must be insulated with insulators.	Otherwise, it may cause electric shock, fire, and malfunction.
About operation and operation		
	Do not touch the inside of the drive.	Otherwise, it may cause fire and malfunction.
	Do not let the cable be damaged, subjected to excessive external force, heavy pressure, or pinched.	Otherwise, it may cause a fire accident.
	Do not touch the rotating part of the motor during operation.	Otherwise, it may cause electric shock, fire, and malfunction
	Do not use it in a place with water, in an environment with corrosive, flammable gas, or near combustible materials.	Otherwise, it may cause a fire accident
	Do not use it in places subject to intense vibration or shock.	Otherwise, it may cause electric shock.
	Do not immerse the cable in oil and water for use.	Otherwise, it may cause electric shock.
	Do not connect and operate with wet hands.	Otherwise, it may cause electric shock, injury malfunction, or damage.
	When using a motor with a keyway on the shaft end, do not touch the keyway with your bare hands.	Otherwise, it may cause a fire accident
	The temperature of the motor, driver, and radiator will rise, please do not touch them.	Otherwise, it may cause electric shock, fire, and malfunction.
	Do not use external power to drive the motor.	Otherwise, it may cause fire and malfunction.

Notes on other use		
!	Be sure to confirm relevant safety after the earthquake.	Otherwise, it may cause a fire accident
	In order to prevent fires and personal accidents in the event of an earthquake, the installation and installation should be carried out properly.	Otherwise, it may cause electric shock, fire, and malfunction.
	An emergency stop circuit must be installed externally to ensure that the operation can be stopped and the power supply can be cut off in time in an emergency.	Otherwise, it may cause fire and malfunction.
About maintenance and inspection		
!	The drive has dangerous high voltage parts. When wiring and inspection work, you must cut off the power supply and leave it to discharge (more than 5 minutes). And, it is absolutely not allowed to decompose it.	Otherwise, it may cause fire and malfunction.

⚠ Notes		
About installation and wiring		
!	The motor and driver must be combined as specified.	Otherwise, it may cause electric shock.
	Do not touch the connector terminals directly.	Otherwise, it may cause electric shock, injury malfunction, or damage.
!	Note that the vents must not be blocked or foreign objects enter.	Otherwise, it may cause a fire accident
	The test run must be carried out with the motor fixed and separated from other mechanical systems.	Otherwise, it may cause electric shock, fire, and malfunction.
	After confirming the action, install it on the mechanical system.	Otherwise, it may cause fire and malfunction.
	Observe the specified installation method and installation direction. Install properly according to the weight of the equipment and the rated output of the product.	Otherwise, it may cause electric shock.
About operation and operation		
⊘	Do not stand on the product or place heavy objects on the product.	Otherwise, it may cause fire and malfunction.
	Prohibition of extreme gain adjustments and changes will cause unstable operation.	Otherwise, it may cause a fire accident.
	Do not use it in places exposed to direct sunlight.	Otherwise, it may cause electric shock, fire, and malfunction
	Do not subject the motor and motor shaft to strong impact.	Otherwise, it may cause a fire accident
	The function of the built-in brake of the motor is to keep the brake, and it is prohibited to use it for normal braking.	Otherwise, it may cause electric shock.
!	When the power supply is restored after a power failure, it may start suddenly, so please do not approach the machine. Make sure to set up the machine to ensure personal safety even after restarting.	Otherwise, it may cause electric shock.
	Do not use faulty or damaged motors and drives.	Otherwise, it may cause electric shock, injury malfunction, or damage.
	Please confirm whether the power supply specifications are normal.	Otherwise, it may cause a fire accident
	The holding brake is not a stopping device to ensure mechanical safety. Install a stop device to ensure safety on the machine side.	Otherwise, it may cause electric shock, fire, and malfunction.
	When alarming, remove the cause of the fault and ensure safety, then clear the alarm and restart.	Otherwise, it may cause fire and malfunction.
	The brake relay and the emergency stop circuit breaker relay must be connected in series.	Otherwise, it may cause a fire accident.
About maintenance and inspection		
⊘	Do not store in places where rain or water splashes, or where there are toxic gases and liquids.	Otherwise, it may cause electric shock.
	When carrying, do not hold the cable or the motor shaft.	Otherwise, it may cause a fire accident
!	Avoid falling or tipping when carrying or installing.	Otherwise, it may cause electric shock, fire, and malfunction.
	If long-term storage is required, please consult the contact method described in this manual.	Otherwise, it may cause fire and malfunction.

	Please keep it in a storage place that complies with the storage environment specified in this manual.	Otherwise, it may cause a fire accident.
Notes on other use		
	When disposing of batteries, please insulate them with tape, etc., and dispose of them in accordance with the regulations of the relevant authorities.	
	Please dispose of it as industrial waste.	
About maintenance and inspection		
	Do not carry out disassembly and repair work except our company.	Otherwise, it may cause fire and malfunction.
	Do not open and close the main circuit power switch frequently.	Otherwise, it may cause a fire accident.
	During power-on or within a certain period of time after the power is cut off, the motor, the radiator of the driver, and the regenerative resistor may be in a high temperature state. Do not touch it.	Otherwise, it may cause electric shock.
	When the drive fails, please cut off the control power supply and the main circuit power supply.	Otherwise, it may cause a fire accident.
	Be sure to cut off the main power supply when not in use for a long time.	Otherwise, it may cause electric shock.
About maintenance and inspection		
<p><Warranty Period></p> <ul style="list-style-type: none"> ◆ The warranty period of the product is 18 months from the month of manufacture of the company. However, for motors with brakes, the number of acceleration and deceleration of the shaft does not exceed the life span. 		
<p><Guaranteed Content></p> <ul style="list-style-type: none"> ◆ According to the normal use of this manual, within the warranty period, it will be repaired free of charge in case of failure. However, even if the following failure occurs during the warranty period, it is a paid repair. <ol style="list-style-type: none"> ① Wrong use, and inappropriate repair and modification. ② When it is dropped after purchase, and the cause of damage during transportation. ③ The reason for using the product beyond the product specifications. ④ Fire, earthquake, thunderstorm, wind and flood, salt damage, abnormal voltage and other natural disasters. ⑤ When water, oil, metal pieces, or other foreign matter invades. ◆ The scope of guarantee is the main body of the deliverable. If the damage is caused by the failure of the deliverable, it is judged to be outside the scope of compensation. 		

Content

Chapter 1 Product description and system selection	5
1.1 Model Type	5
1.2 The name of each part of the drive	5
Chapter 2 Product specifications	7
2.1 Servo drive specifications	7
Chapter 3 Servo Motor and Drive Installation and Dimensions	10
3.1 Install environment	10
3.2 Installation concentricity	10
3.3 Servo drive installation size	10
Chapter 4 Servo motor and driver wiring instructions	12
4.1 System wiring diagram example	12
5.1 Position mode wiring	13
Chapter 5 Wiring	13
5.2 Speed/torque mode wiring	14
5.3 Detailed description of user I/O connector terminal arrangement	14
Appendix	16
Chapter 6 Parameter summary	17
P00 Group Servo motor datasheet	17
P01 Group Servo Drive datasheet	18
P02 Group Basic control parameters	18
P03 Group Terminal input parameters	20
P04 Group Terminal output parameters	22
P05 Group Position control parameters	24
P06 Group Speed control parameters	28
P08 Group Gain class parameters	30
P0A Group Fault and Protection Parameters	33
P0C Group Communication parameters	36
P0F Group Full closed-loop functional parameters	37
P12 Group Multi-segment speed parameter	43
P17 Group Virtual DIDO parameters	47
P31GroupCommunication gives servo-related variables	50
DIDO Function definition	50
Chapter 7 Trouble shooting	55
7.1 Fault and warning handling at startup	55
7.2 Runtime failures and warning handling	60

Chapter 1 Product description and system selection

1.1 Model Type

LCDA	55		15		R23		M15		34		P	
①	②		③		④		⑤		⑥		⑦	
Serial Number	Power rating		Current		Encoder		Speed		Voltage		Product Category	
	logo	Power	logo	Current	logo	Spec	logo	Spec	logo	Spec	logo	Spec
	55	5.5KW	17	17A	C17	SPC-17bit	M15	1500R	32	3P-220V	P	pulse
	75	7.5KW	25	25A	R17	APC-17bit	M17	1700R	34	3P-380V	C	CAN open
	110	11KW	32	32A	C23	SPC-23bit	M20	2000R			N	Ether CAT
	130	13KW	45	45A	R23	APC-23bit	M25	2500R				
	180	18KW	60	60A								

1.2 The name of each part of the drive

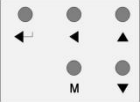
Model	Specification
Digital tube display	The 5-digit 7-segment LED digital tube is used to display the running status and parameter setting of the servo.
Key operator	 <p> : Set key. Press this key to display the setting and setting value of each parameter, and enter the parameter setting state (long press the parameter to confirm); ◀: DATA key. Press this key to move the selected digit (the decimal point of the digit flashes) to the left; : UP key. The set value can be increased as a forward start key when the auxiliary function mode JOG is running; M: MODE key. Switch basic mode: status display, auxiliary function, parameter setting, monitoring; : DOWN key. It can reduce the set value and act as the reverse start key during the auxiliary function mode JOG operation. </p>
CHARGE Bus voltage indicator	Used to indicate that the bus capacitor is in a charged state. When the indicator light is on, even if the main circuit power supply is OFF, the internal capacitor of the servo unit may still be charged. Therefore, do not touch the power terminals when the light is on to avoid electric shock.
L1、L2、L3	Three phase AC200V-240V, -15%~10%, 50/60Hz; Or three phase AC380V-440V, -15%~10%, 50/60Hz.
L1C、L2C Control power terminal	Single phase AC200V-240V, -15%~10%, 50/60Hz. (380V Without this terminal)
01、02 (Empty feet)	1: BusbarN; 2: Empty feet
B1/⊕、B2、B3 Braking resistor terminal	When using an external braking resistor, connect a braking resistor between B1/⊕ and B2; when using an internal braking resistor, short-circuit B2 and B3 (B2 and B3 have been short-circuited before leaving the factory).
U、V、W、⊕ Motor power terminal and ground terminal	It must correspond to the UVW terminals of the motor one by one.

CN1 Motor encoder terminal	Note the terminal definition
CN2 Input and output terminals	Note the terminal definition.
CN3、CN4 Communication terminal	Internal parallel connection, connected with RS-232, RS-485, Canopen communication command device.

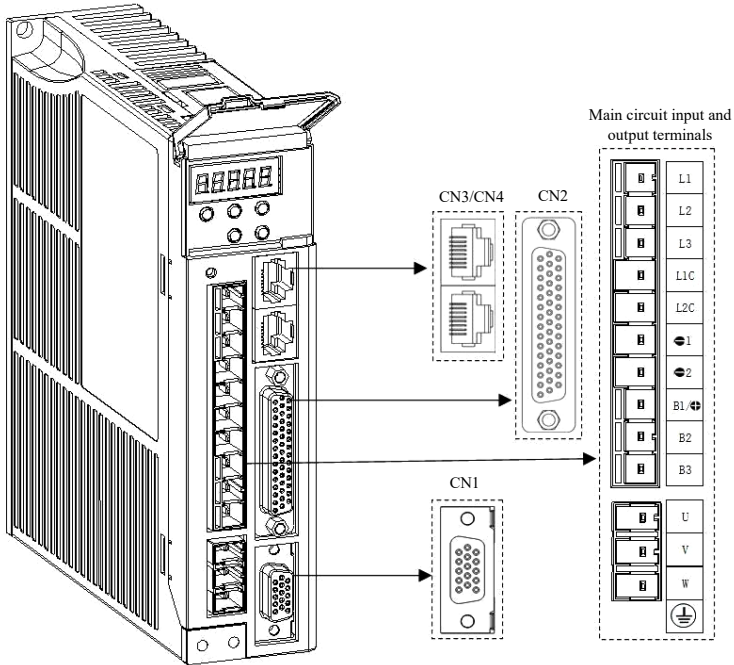

Chapter 2 Product specifications

2.1 Servo drive specifications

Item		Specifications		
Model Type LCDA630P		5.5KW-7.5KW(220V)		
Outlook	W(mm)	110		
	H(mm)	222		
	D(mm)	201		
	Weight(kg)	4.0		
	Input Power	Three phase AC200V-240V,-15%~10%, 50/60Hz		
Model Type LCDA630P		5.5KW-18KW(380V)		
Outlook	W(mm)	110	206	224
	H(mm)	222	368	463
	D(mm)	201	215	215
	Weight(kg)	4.0	8.3	12
	Input Power	Three phase AC380V-440V, -15%~10%, 50/60Hz		
Environment	°C	Use environment humidity	0~55°C	
		Storage environment humidity	-20~65°C	
	Humidity	Use environment humidity	20~85% RH below (No condensation)	
		Storage environment humidity	20~85% RH below (No condensation)	
	Use to preserve ambient air		indoor (no sunshine), No corrosive gas, flammable gas, oil mist, dust	
	altitude		Below 1000m	

Item		Specifications		
	vibration	5.8m/s ² (0.6G) below 10~60Hz (Can not be used continuously at resonance frequency)		
	Insulation withstand voltage	Basic—FG between AC1500V 1min		
	Control way	Three-phase PWM converter sine wave drive		
	Encoder feedback	1: Provincial line 2500 line 2: 17bit (after adding a battery, it can be used as a multi-turn absolute encoder)		
	Control signal	Input	9 inputs (DC24V optocoupler isolation) switch according to the control mode function	
		Output	5 output (DC24V optocoupler isolation, open collector output) switch according to the control mode function	
	Pulse signal	Input	2 inputs (optocoupler isolation, RS-422 differential, open collector output)	
		Output	4 outputs (A/B/Z phase RS-422 differential; Z phase open collector output)	
	Communication function	RS232	For PC communication (for "Servostudio" connection)	
		RS-485	For upper remote control communication (1:n)	
		CAN	CANOPEN bus communication	
	Regeneration function	Optional regenerative resistor, external regenerative resistor. Pay attention to modify internal parameters		
	Dynamic brake	YES		
Control model	6 control modes: speed control, position control, torque control, torque/speed control, speed/position control, torque/position, torque/speed/position hybrid control			
Function	Control input	Alarm reset, proportional action switching, zero fixed function enable, forward drive prohibited, reverse drive prohibited, external torque limit for forward rotation, external torque limit for reverse rotation, forward jog, reverse jog, forward Reset switch, reverse reset switch, origin switch, emergency stop, servo enable, gain switch		
	Control output	Servo ready, motor rotating, zero speed signal, speed reached, position reached, positioning approach signal, torque limit, speed limit, brake output, warning, servo failure, alarm code (3-digit output)		
	Position cont	Pulse input	Maximum command pulse frequency	Differential input: high-speed maximum 4Mpps, pulse width cannot be less than 0.125μs The maximum low speed is 500Kpps, and the pulse width cannot be less than 1μs Open collector: maximum 200Kpps, pulse width cannot be less than 2.5μs
			Input pulse signal form	Differential input; open collector
			Input pulse signal method	Pulse + direction, right angle phase difference (A phase + B phase), CW + CCW pulse
		Command pulse division/multiplication (Electronic gear ratio setting)	0.1048576 < B/A < 419430.4	
		Command filter	Smoothing filter, FIR filter	
		Pulse output	Output pulse form	Phase A, Phase B: Differential output Z phase: differential output or open collector output
	Frequency division ratio		Arbitrary frequency division	
	Output pulse function		Encoder position pulse and position pulse command (can be set)	
	Speed control	Control input	Servo ON, alarm reset, speed command reverse, zero speed clamp, internal command selection input 1, internal command selection input 2, internal command selection input 3, internal command selection input 4, forward rotation external torque limit input, reverse rotation External torque limit input, emergency stop	
		Control output	Alarm status, servo preparation, brake release, torque limit output, speed limit output speed reached, speed consistent, motor rotation output, zero-speed signal output	

Item		Specifications	
	Torque control	Control input	Servo ON, alarm reset, torque command reverse, zero speed clamp
		Control output	Alarm status, servo preparation, brake release, torque limit, speed limit output, emergency stop
		Torque command input	(Factory default setting, the range can be set by function code)
		Speed limit function	Positive and negative internal speed limit P03.27, P03.28
	Common	Speed observer function	YES
		Damping control function	YES
		Adaptive notch filter	YES
		Automatic adjustment function	YES
		Encoder output frequency division	YES
		Internal location planning function	YES
Adjustment/function setting	Use the host computer setting software "Servostudio" to adjust		
Protection	Over voltage, abnormal power supply, overcurrent, overload, abnormal encoder, overspeed, excessive position deviation, abnormal parameters, etc.		

Chapter 3 Servo Motor and Drive Installation and Dimensions

3.1 Install environment

Regarding environmental conditions, please be sure to comply with the specifications set by our company. If you need to use it outside the specified environmental conditions, please consult our company in advance.

- ① Install in a place that will not be directly exposed to sunlight.
- ② The driver must be installed in the control box
- ③ Install it in a place where it will not be immersed by water or oil (cutting oil, oil mist) and without moisture.
- ④ Keep away from corrosive atmospheres such as explosive and flammable gas, sulfide gas, chlorinated gas, ammonia, etc., acid/alkali and salt.
- ⑤ A place that will not be disturbed by dust, iron powder, cutting powder, etc.
- ⑥ Keep away from high temperature places, places with continuous vibration and excessive shock.

3.2 Installation concentricity

When connecting with machinery, use flexible couplings as much as possible, and keep the axis of the servo motor and the axis of the mechanical load in a straight line. When installing the servo motor, it should meet the concentricity tolerance requirements in the figure below.

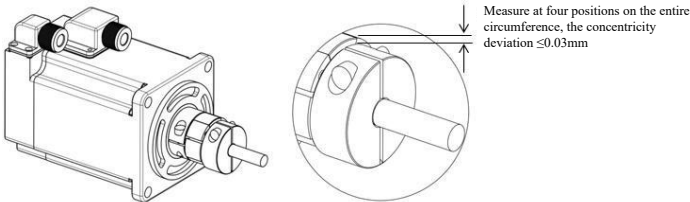

Measured at quarters of a circle, the difference between the largest and smallest is less than 0.03mm. (Rotate with the coupling)

3.3 Servo drive installation size

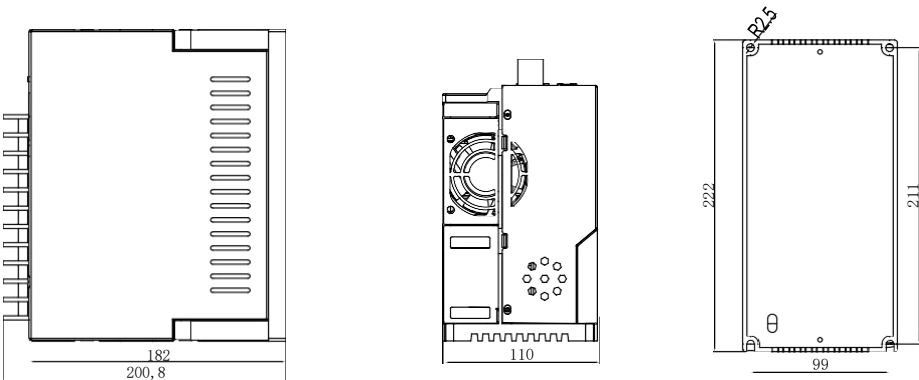

3.4 Driver installation direction and interval

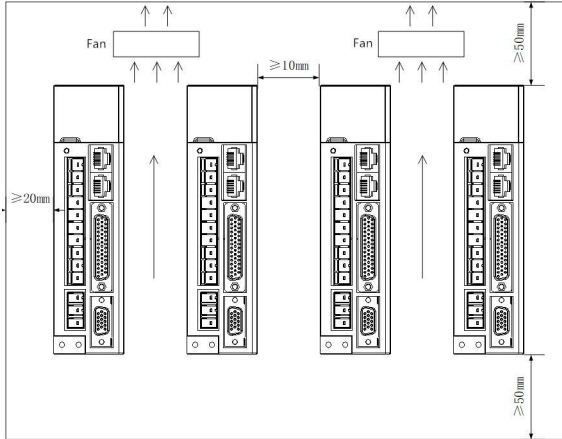

When setting up the drive, in order to ensure the heat dissipation and heat convection in the protection box or the control box, sufficient space should be left around.

For the driver, install it in the vertical direction. When installing the driver, please use two M4 screws to fix it.

When installed in a sealed box such as a control box, in order to ensure that the surrounding temperature of the internal boards does not exceed 55°C, it is necessary to install a fan or cooler for cooling.

The surface of the heat sink will be 30°C higher than the surrounding temperature.

Use heat-resistant materials for wiring materials, and isolate them from devices and wiring that are easily affected by temperature.

The service life of the servo drive depends on the temperature around the internal electrolytic capacitor. When the electrolytic capacitor reaches the end of its service life, the electrostatic capacitance decreases and the internal resistance increases. Due to the above reasons, please be aware that it will cause overvoltage alarms, malfunctions caused by noise, and damage to various components. The life of an electrolytic capacitor is about 5 to 6 years under the conditions of "an average of 30°C per year, a load rate of 80%, and an average of 20 hours a day."

Chapter 4 Servo motor and driver wiring instructions

4.1 System wiring diagram example

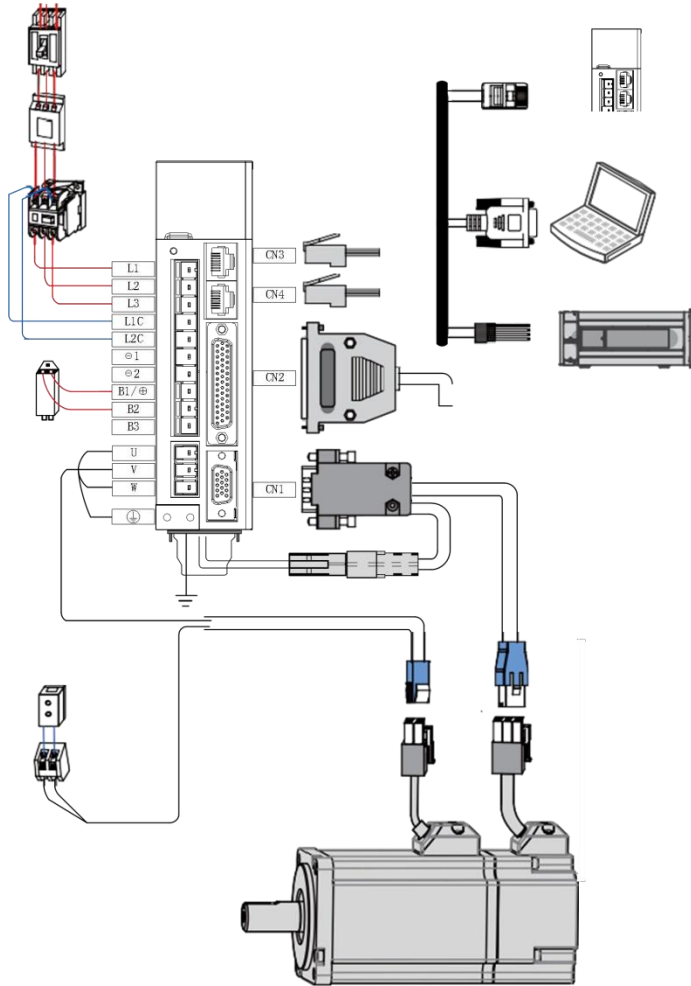

Please pay attention to the power capacity when connecting external control power supply or 24Vdc power supply, especially when supplying power to several drives or multiple brakes at the same time. Insufficient power capacity will result in insufficient power supply current and failure of the drive or brake. The brake power supply is a 24V DC voltage source, and the power needs to refer to the motor model and meet the brake power requirements.

Precautions for system wiring:

1. When connecting an external braking resistor, disconnect the short wiring between terminals B2 and B3 of the servo drive before connecting. Pay attention to modify internal parameters.

- CN3 and CN4 are two pin definitions exactly the same communication interface, you can choose between them.
- In single-phase 220V wiring, the main circuit terminals are L1 and L2. Do not connect the reserved terminals.

Chapter 5 Wiring

5.1 Position mode wiring

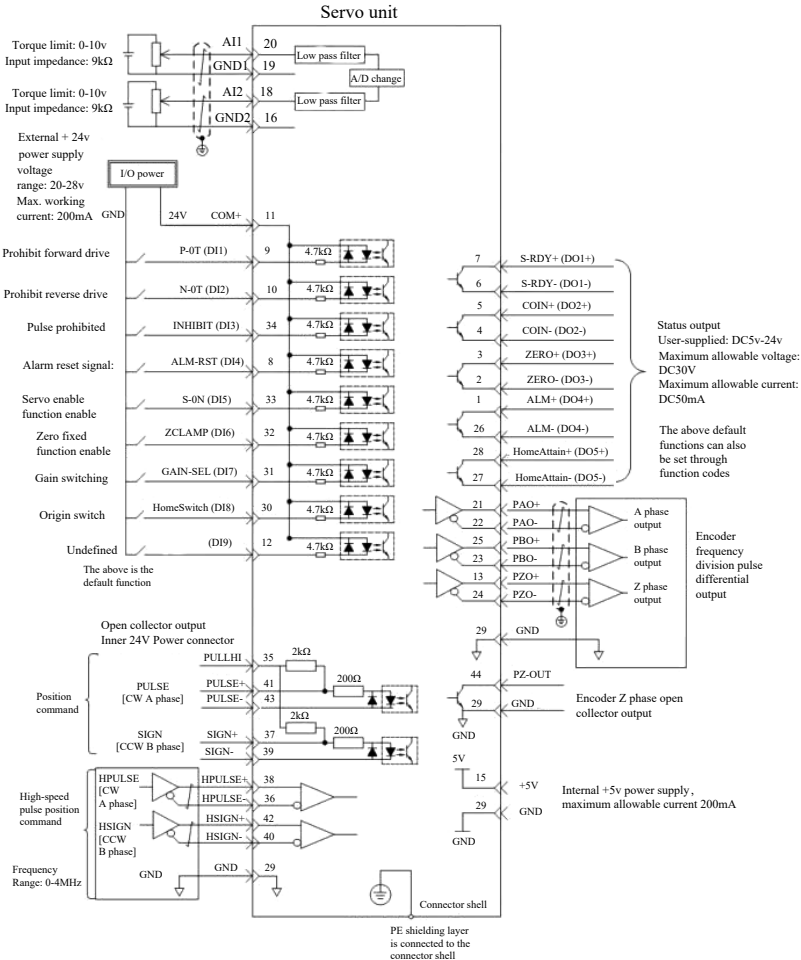

5.2 Speed/torque mode wiring

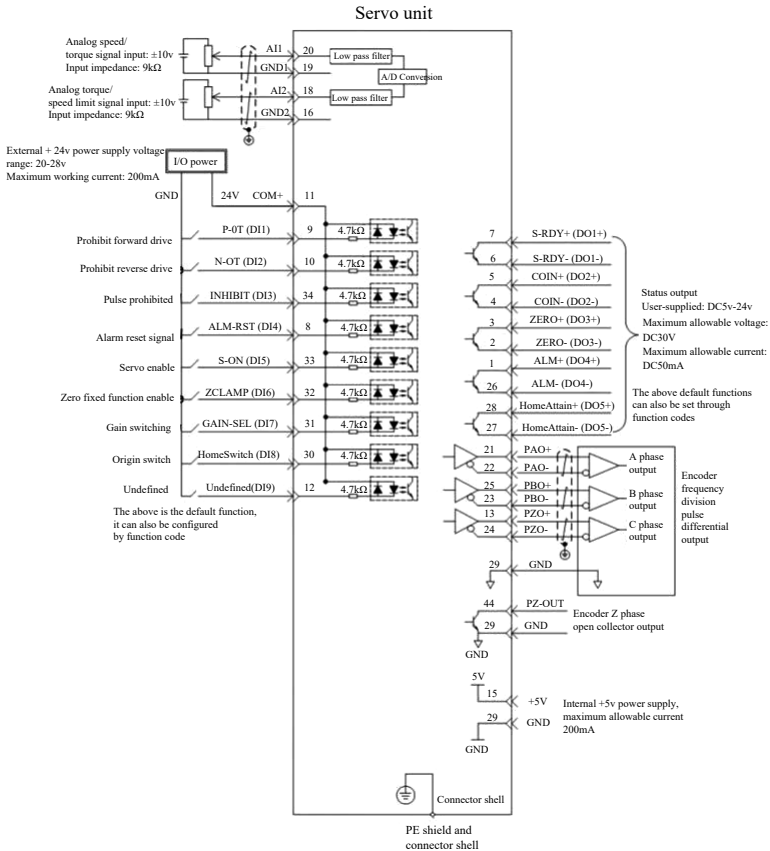

Notes:

- Signal cables and power cables must be routed separately, at least 30cm apart;
- When the signal cable is not long enough to connect the cable, the shielding layer must be reliably connected to ensure reliable shielding and grounding;
- + 5V is referenced to GND. Do not exceed the maximum allowable current, otherwise the drive will not work normally.

5.3 Detailed description of user I/O connector terminal arrangement

5.3.1 CN2 Illustration of terminal arrangement

15 +5V	14 COM-	13 PZO+	12 DI9	11 COM+	10 DI2	9 DI1	8 DI4	7 DO1+	6 DO1-	5 DO2+	4 DO2-	3 DO3+	2 DO3-	1 DO4+
30 DI8	29 GND	28 DO5+	27 DO5-	26 DO4-	25 PBO+	24 PZO-	23 PBO-	22 PAO-	21 PAO+	20 AI1	19 GND1	18 AI2	17 +24V	16 GND2
44 PZ-OUT	43 PULSE-	42 HSIGN+	41 PULSE+	40 HSIGN-	39 SIGN-	38 HPULSE+	37 SIGN+	36 HPULSE-	35 PULLHI	34 DI3	33 DI5	32 DI6	31 DI7	

Note: ■ When the power supply voltage is 380VAC, the terminal arrangement is shown in the figure above; when the power supply voltage is 220VAC, pins 14/17 are defined as empty pins.

Connector pattern diagram

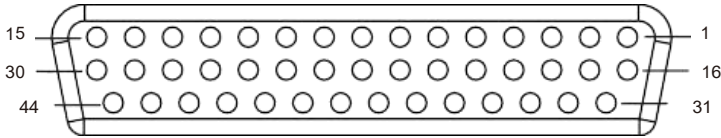

5.3.2 CN1 Illustration of terminal arrangement

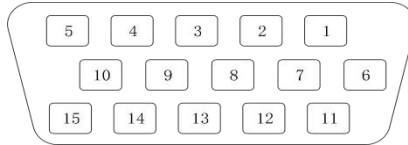

Terminal No.	2500 lines/absolutevalue signal lead name		Terminal No.	2500 lines/absolutevalue signal lead name	
	Name	Function		Name	Function
2	A+	PG input A+ phase	15	Z-	PG input Z-phase
3	A-	PG input A- phase	6	PG5V	PG power +5V
4	B+	PG input B+ phase	12	PS+	Bus type communication signal+
5	B-	PG input B- phase	7	PS-	Bus type communication signal-
10	Z+	PG input Z+ phase	1	GND	Signal ground

5.3.3 CN3、CN4 Illustration of terminal arrangement

Pin number	Definition	Description	Terminal pin distribution
1	CANH	CAN communication port	
2	CANL		
3	GND	CAN communication ground	
4	RS485+	RS485 communication port	
5	RS485-		
6	RS232-TXD	RS232 sending end, connected with the receiving end of the host computer	
7	RS232-RXD	RS232 receiving end, connected with the sending end of the host computer	
8	GND	Ground	
Shell	PE	shield	

Appendix

➤ Recommended cables and wires

Cables	AWG	UL	Heat resistant	Notes
Motor power (<750W)	18	2517	105°C	
Motor power (>1kW)	14 ¹⁾	2501	105°C	
AC220V input (<750W) ※include FG cable	18	1015 quite	105°C	
AC220V input (>1kW) ※ include FG cable	14 ¹⁾	1015 quite	105°C	
Encoder	Power: 22 Signal: 24	20276	80°C	5P (10 core) shielded wire maximum 20m (When using shielded twisted pair cable)
User I/O	26	1007 quite	80°C	Shielded twisted pair cable Recommended length below 50cm
Regenerative resistor connection	18	1015	105°C	
Resistor	18	2517	105°C	1P (2 cores)
Communication between drives ²⁾	28	20539quite	80°C	Ribbon cable 10-core Accessories (2.54mm pitch)

Note: ■ Cable length should be determined according to actual usage conditions.

- 1) 1kW servo motor can use AWG16 wire.
- 2) For multi-axis drives.

⇒ Wiring instructions for servo drive power connector (L1C/ L2C, L1/ L2/ L3, U/ V/ W)

Use the included spudger when wiring.
Cable connection steps:

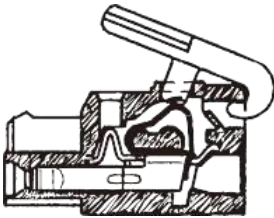

1) The wiring rod is installed on the bracket.
(Free loading and unloading)

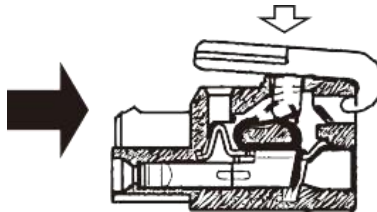

2) Depress the wiring rod in the direction of the arrow

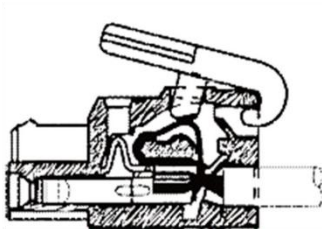

4) Loosen the wiring rod.

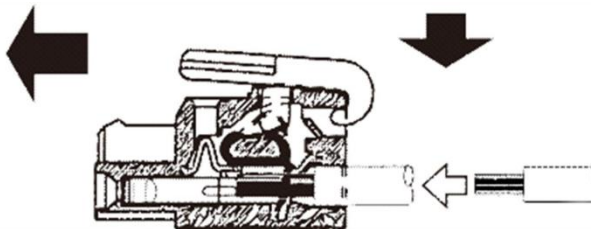

3) Press the terminal bar and insert the cable in the direction of the arrow.

Chapter 6 Parameter summary

Function code	Data specifications	Function code	Data specifications
P00 group	Servo motor parameters	P0A group	Fault and protection parameters
P01 group	Drive parameters	P0B group	Monitoring parameters
P02 group	Basic control parameters	P0C group	Communication parameters
P03 group	Terminal input parameters	P0D group	Auxiliary function parameters
P04 group	Terminal output parameters	P0F group	Full closed loop function parameters
P05 group	Position control parameters	P11 group	Multi-segment position function parameters
P06 group	Speed control parameters	P12 group	Multi-stage speed parameters
P07 group	Torque control parameters	P17 group	Virtual DIDO parameters
P08 group	Gain parameters	P30 group	Communication read servo related variables
P09 group	Self-tuning parameters	P31 group	Communication given servo related variables

P00 Group Servo motor datasheet

Function code	Name	Setting range	Unit	Factory setting	Effective way	Setting way	Related patterns
P00	00 Motor number	14130: Domochuan absolute encoder motor 22□□□: 220V Class Incremental Encoder Motor 38□□□: 380V Class Incremental Encoder Motor	-	14130	Re-energize	Stop setting	ALL
P00	02 Non-standard	-	-	-	-	Display	-
P00	04 Encoder version number	-	-	-	-	Display	-
P00	05 Bus Motor Number	-	-	-	-	Display	-
P00	08 Absolute Encoder Type	14100: Multi-loop absolute encoder Other: Single-loop absolute encoder	-	-	Re-energize	Stop setting	ALL
P00	09 Rated voltage	0-220 1-380	V	-	Re-energize	Stop setting	-
P00	10 Rated power	0.01~655.35	kW	-	Re-energize	Stop setting	-
P00	11 Rated current	0.01~655.35	A	-	Re-energize	Stop setting	-
P00	12 Rated torque	0.01~655.35	Nm	-	Re-energize	Stop setting	-
P00	13 Max torque	0.10~655.35	Nm	-	Power up again	Stop setting	-
P00	14 Rated speed	100~6000	rpm	-	Power up again	Stop setting	-
P00	15 Max speed	100~6000	rpm	-	Power up again	Stop setting	-
P00	16 rotary inertia Jm	0.01~655.35	kgcm ²	-	Power up again	Stop setting	-
P00	17 Permanent magnet synchronous motor pole logarithm	2~360	Opposite	-	Power up again	Stop setting	-
P00	18 stator resistance	0.001~65.535	Ω	-	Power up again	Stop setting	-

Function code	Name	Setting range	Unit	Factory setting	Effective way	Setting way	Related patterns	
P00	19	Stator Inductance Lq	0.01~655.35	mH	-	Power up again	Stop setting	-
P00	20	Stator Inductance Ld	0.01~655.35	mH	-	Power up again	Stop setting	-
P00	21	Line back EMF coefficient	0.01~655.35	mV/rpm	-	Power up again	Stop setting	-
P00	22	Moment coefficient Kt	0.01~655.35	Nm/Arms	-	Power up again	Stop setting	-
P00	23	Electrical constant Te	0.01~655.35	ms	-	Power up again	Stop setting	-
P00	24	Mechanical constant Tm	0.01~655.35	ms	-	Power up again	Stop setting	-
P00	28	Absolute dial position bias	0~1073741824	P/r	-	Power up again	Stop setting	-
P00	30	Encoder Selection (HEX)	0 x000- Ordinary incremental encoder (UVW-ABZ) 0 x013-17bit Bus incremental encoder	1	0x013	Power up again	Stop setting	-
P00	31	Encoder Line Number	0~1073741824	P/r	1048576	Power up again	Stop setting	-
P00	33	Z Signal correspondence angle	0.0~360	°	180	Power up again	Stop setting	-
P00	34	U rise along the corresponding angle	0.0~360	°	180	Power up again	Stop setting	-

P01 Group Servo Drive datasheet

Function code	Name	Setting range	Unit	Factory setting	Effective way	Setting way	Related patterns	
P01	00	MCU Software Version Number	0~65535	-	-	Display	-	
P01	01	FPGA Software Version Number	0~65535	-	-	Display	-	
P01	02	Servo Driver Number	0~65535	-	-	Power up again	Stop setting	-

P02 Group Basic control parameters

Function code	Name	Setting range	Unit	Factory setting	Effective way	Setting way	Related patterns	
P02	00	Control Mode Selection	0: Speed mode 1: position mode 2: Torque mode 3: Torque mode↔speed mode 4: Speed mode↔Position mode 5: Torque mode↔Position mode 6: Torque mode↔speed↔position hybrid mode	-	1	Effective immediately	Stop setting	-
P02	01	Absolute value system selection	0: Incremental Location Mode 1: Absolute Position Linear Mode 2: Absolute position rotation mode	-	0	Power up again	Stop setting	ALL
P02	02	Direction of rotation	0: take the CCW direction as the positive direction (A lead B) 1: in CW direction (reversal mode, A lag B)	-	0	Power up again	Stop setting	PST
P02	03	Output pulse phase	0: take the CCW direction as the positive direction (A lead B) 1: in CW direction (reversal mode, A lag B)	-	0	Power up again	Stop setting	PST

Function code	Name	Setting range	Unit	Factory setting	Effective way	Setting way	Related patterns
P02	05 Servo enable OFF downtime option	0: free shutdown, maintain free running state 1: zero speed shutdown, maintain free running state	-	0	Effective immediately	Stop setting	PST
P02	06 Fault No.2 Stop Mode Selection	0: free shutdown, maintain free running state 1: zero speed shutdown, maintain free running state	-	0	Effective immediately	Stop setting	PST
P02	07 Choice of Overhaul Mode	0: free shutdown, maintain free running state 1: zero speed shutdown, position locked 2: zero speed shutdown, maintain free running state	-	1	Effective immediately	Stop setting	PST
P02	08 Fault No.1 Stop Mode Selection	0~ Free shutdown, free running	-	0	Effective immediately	Stop setting	PST
P02	09 Hold gate output ON to receive instruction delay	0~500	ms	250	Effective immediately	Run settings	PS
P02	10 Static state, lock output OFF to motor no power delay	1~1000	ms	150	Effective immediately	Run settings	PS
P02	11 Rotating state, speed threshold when output OFF	0~3000	rpm	30	Effective immediately	Run settings	PS
P02	12 Rotate state, motor does not power to lock output OFF delay	1~1000	ms	500	Effective immediately	Run settings	PS
P02	15 LED Warning Display Select	0: immediately output warning messages 1: do not output warning messages	-	0	Effective immediately	Stop setting	PST
P02	18 Servo Enable (S-ON) Filter time constant	0~64	ms	0	Effective immediately	Stop setting	PST
P02	21 Brake resistance minimum allowed by driver	-	Ω	-	-	Display	PST
P02	22 Built-in Brake Resistance Power	-	W	-	-	Display	PST
P02	23 Built-in brake resistance	-	Ω	-	-	Display	PST
P02	24 Resistance heat dissipation factor	10~100	%	30	Effective immediately	Stop setting	PST
P02	25 Brake resistance settings	0: Use Built-in Brake Resistance 1: external brake resistance, natural cooling 2: use external brake resistor to force air cooling 3: does not use brake resistance, all rely on capacitance absorption	-	0	Effective immediately	Stop setting	PST
P02	26 External brake resistance power	1~65535	W	-	Effective immediately	Stop setting	PST
P02	27 External brake resistance resistance	1~1000	Ω	-	Effective immediately	Stop setting	PST
P02	30 User password	0~65535	-	0	Power up again	Stop setting	PST

Function code	Name	Setting range	Unit	Factory setting	Effective way	Setting way	Related patterns
P02 31	System parameter initialization	0: no operation 1: Recovery of factory setting (except P00/P01 sets of parameters) 2: troubleshooting records	-	0	Effective immediately	Stop setting	PST
P02 32	Panel Default Display	0~99	-	50	Effective immediately	Run settings	-
P02 33	EtherCAT Software Version Number	-	-	-	-	Display	-
P02 34	CAN Software Version Number	-	-	-	-	Display	-
P02 38	Fault short circuit braking time	0~30000	ms	5000	Effective immediately	Run settings	PST
P02 39	Fault Short Circuit Brake Threshold	0-3000	0.1%	1000	Effective immediately	Run settings	PST

P03 Group Terminal input parameters

Function code	Name	Setting range	Unit	Factory setting	Effective way	Setting method	Related patterns
P03 00	Effective DI function distribution 1	0~0xFFFF Bit0: correspond FunIN.1 Bit1: correspond FunIN.2 Bit15: correspond FunIN.16	-	0	Power up again	Run settings	-
P03 01	Effective DI function distribution 2	0~0xFFFF Bit0: correspond FunIN.17 Bit1: correspond FunIN.18 Bit15: correspond FunIN.32	-	0	Power up again	Run settings	-
P03 02	DI1 Terminal function selection	0~37	-	14	Outage takes effect	Run settings	-
P03 03	DI1 Terminal logic selection	Input polarity :0~4 0: means low level valid 1: indicates high level of efficiency 2: indicates that the rising edge is effective 3: indicates that the decline is effective 4: indicates that the rising and falling edges are effective	-	0	Outage takes effect	Run settings	-
P03 04	DI2 Terminal function selection	0~37	-	15	Outage takes effect	Run settings	-
P03 05	DI2 Terminal logic selection	Input polarity :0~4 0: means low level valid 1: indicates high level of efficiency 2: indicates that the rising edge is effective 3: indicates that the decline is effective 4: indicates that the rising and falling edges are effective	-	0	Outage takes effect	Run settings	-
P03 06	DI3 Terminal function selection	0~37	-	13	Outage takes effect	Run settings	-

Function code	Name	Setting range	Unit	Factory setting	Effective way	Setting method	Related patterns
P03 07	DI3 Terminal logic selection	Input polarity :0~4 0: means low level valid 1: indicates high level of efficiency 2: indicates that the rising edge is effective 3: indicates that the decline is effective 4: indicates that the rising and falling edges are effective	-	0	Outage takes effect	Run settings	-
P03 08	DI4 Terminal function selection	0~37	-	2	Outage takes effect	Run settings	-
P03 09	DI4 Terminal logic selection	Input polarity :0~4 0: means low level valid 1: indicates high level of efficiency 2: indicates that the rising edge is effective 3: indicates that the decline is effective 4: indicates that the rising and falling edges are effective	-	0	Outage takes effect	Run settings	-
P03 10	DI5 Terminal function selection	0~37	-	1	Outage takes effect	Run settings	-
P03 11	DI5 Terminal logic selection	Input polarity :0~4 0: means low level valid 1: indicates high level of efficiency 2: indicates that the rising edge is effective 3: indicates that the decline is effective 4: indicates that the rising and falling edges are effective	-	0	Outage takes effect	Run settings	-
P03 12	DI6 Terminal function selection	0~37	-	12	Outage takes effect	Run settings	-
P03 13	DI6 Terminal logic selection	Input polarity :0~4 0: means low level valid 1: indicates high level of efficiency 2: indicates that the rising edge is effective 3: indicates that the decline is effective 4: indicates that the rising and falling edges are effective	-	0	Outage takes effect	Run settings	-
P03 14	DI7 Terminal function selection	0~37	-	3	Outage takes effect	Run settings	-
P03 15	DI7 Terminal logic selection	Input polarity :0~4 0: means low level valid 1: indicates high level of efficiency 2: indicates that the rising edge is effective 3: indicates that the decline is effective 4: indicates that the rising and falling edges are effective	-	0	Outage takes effect	Run settings	-
P03 16	DI8 Terminal function selection	0~37	-	31	Outage takes effect	Run settings	-

Function code	Name	Setting range	Unit	Factory setting	Effective way	Setting method	Related patterns
P03	17 DI8 Terminal logic selection	Input polarity :0~4 0: means low level valid 1: indicates high level of efficiency 2: indicates that the rising edge is effective 3: indicates that the decline is effective 4: indicates that the rising and falling edges are effective	-	0	Outage takes effect	Run settings	-
P03	18 DI9 Terminal function selection	0~37	-	0	Outage takes effect	Run settings	-
P03	19 DI9 Terminal logic selection	Input polarity :0~4 0: means low level valid 1: indicates high level of efficiency 2: indicates that the rising edge is effective 3: indicates that the decline is effective 4: indicates that the rising and falling edges are effective	-	0	Outage takes effect	Run settings	-
P03	34 Effective DI Function Distribution 3	0~0xFFFF Bit0: corresponding FunIN.33 Bit1: corresponding FunIN.34 Bit15: corresponding FunIN.48	-	0	Power up again	Run settings	-
P03	35 Effective DI Function Distribution 4	0~0xFFFF Bit0: corresponding FunIN.49 Bit1: corresponding FunIN.50 Bit15: corresponding FunIN.64	-	0	Power up again	Run settings	-
P03	50 AI1 offset	-5000~5000	mV	0	Effective immediately	Run settings	-
P03	51 AI1 Input filter time constant	0~655.35	ms	2.00	Effective immediately	Run settings	-
P03	53 AI1 blind spot	0~1000.0	mV	10.0	Effective immediately	Run settings	-
P03	54 AI1 drift	-500.0~500.0	mV	0.0	Effective immediately	Run settings	-
P03	55 AI2 offset	-5000~5000	mV	0	Effective immediately	Run settings	-
P03	56 AI2 Input filter time constant	0~655.35	ms	2.00	Effective immediately	Run settings	-
P03	58 AI2 blind spot	0~1000.0	mV	10.0	Effective immediately	Run settings	-
P03	59 AI2 drift	-500.0~500.0	mV	0.0	Effective immediately	Run settings	-
P03	80 Analog 10 V corresponding velocity	0rpm~9000rpm	1rpm	3000rpm	Effective immediately	Stop setting	-
P03	81 Analog 10 V corresponding torque	1.00 times ~8.00 times rated torque	1.00 times rated torque	1.00 times rated torque	Effective immediately	Stop setting	-

P04 Group Terminal output parameters

Function code	Name	Setting range	Unit	Factory setting	Effective way	Setting method	Related patterns
---------------	------	---------------	------	-----------------	---------------	----------------	------------------

Function code	Name	Setting range	Unit	Factory setting	Effective way	Setting method	Related patterns
P04 00	DO1 Terminal function selection	0~22	-	1	Outage takes effect	Run settings	-
P04 01	DO1 Terminal logic selection	Output polarity reversal settings :0~1 The output L low level when 0: indicates valid (optocoupler conduction) 1: output H high level when valid (optocoupler off)	-	0	Outage takes effect	Run settings	-
P04 02	DO2 Terminal function selection	0~22	-	5	Outage takes effect	Run settings	-
P04 03	DO2 Terminal logic selection	Output polarity reversal settings :0~1 The output L low level when 0: indicates valid (optocoupler conduction) 1: output H high level when valid (optocoupler off)	-	0	Outage takes effect	Run settings	-
P04 04	DO3 Terminal function selection	0~22	-	3	Outage takes effect	Run settings	-
P04 05	DO3 Terminal logic selection	Output polarity reversal settings :0~1 The output L low level when 0: indicates valid(optocoupler conduction) 1: output H high level when valid (optocoupler off)	-	0	Outage takes effect	Run settings	-
P04 06	DO4 Terminal function selection	0~22	-	11	Outage takes effect	Run settings	-
P04 07	DO4 Terminal logic selection	Output polarity reversal settings :0~1 The output L low level when 0: indicates valid (optocoupler conduction) 1: output H high level when valid (optocoupler off)	-	0	Outage takes effect	Run settings	-
P04 08	DO5 Terminal function selection	0~22	-	16	Outage takes effect	Run settings	-
P04 09	DO5 Terminal logic selection	Output polarity reversal settings :0~1 The output L low level when 0: indicates valid (optocoupler conduction) 1: output H high level when valid (optocoupler off)	-	0	Outage takes effect	Run settings	-
P04 22	DO original selection	0~31	-	0	Effective immediately	Stop setting	-
P04 50	AO1 Signal selection	00: motor speed V/1000rpm 01: speed instruction (1 V/1000rpm) 02: torque instruction (1 V/100%) 03: position deviation (0.05 V/ instruction unit) 04: position deviation (0.05 V/ encoder unit)05: position instruction speed (1 V/1000rpm) 06: Positioning Completion Instruction (Location completed :5 V Location not completed :0 V) 07: speed feedforward (1 V/1000rpm) 08: AI1 voltage 09: AI2 voltage	-	0	Effective immediately	Run settings	-

Function code	Name	Setting range	Unit	Factory setting	Effective way	Setting method	Related patterns
P04 51	AO1 offset voltage	-10000~10000	mV	5000	Effective immediately	Run settings	-
P04 52	AO1 multiplying power	-99.99 ~99.99	Times	1.00	Effective immediately	Run settings	-
P04 53	AO2 Signal selection	00: motor speed (1V/1000rpm) 01: speed instruction (1 V/1000rpm) 02: torque instruction (1 V/100%) 03: position deviation (0.05 V/instruction unit) 04: position deviation (0.05 V/encoder unit) 05: position instruction speed (1 V/1000rpm) 06: Positioning Completion Instruction (Location completed: 5 V Location not completed : 0 V) 07: speed feedforward (1 V/1000rpm) 08: AI1 voltage 09: AI2 voltage	-	0	Effective immediately	Run settings	-
P04 54	AO2 offset voltage	-10000~10000	mV	5000	Effective immediately	Run settings	-
P04 55	AO2 multiplying power	-99.99 ~99.99	Times	1.00	Effective immediately	Run settings	-

P05 Group Position control parameters

Function code	Name	Setting range	Unit	Factory setting	Effective way	Setting method	Related patterns
P05 00	Location instruction source	0: Pulse Instruction 1: step given 2: multi-segment position instruction given	-	0	Effective immediately	Stop setting	P
P05 01	Pulse instruction input terminal selection	0: low speed 1: High Speed	-	0	Effective immediately	Stop setting	P
P05 02	Number of position instructions per rotation of motor	0 ~1048576	P/r	0	Power up again	Stop setting	P
P05 04	First-order low-pass filter time constant	0~6553.5	ms	0.0	Effective immediately	Stop setting	P
P05 05	Step by step	-9999 ~9999	指令单位	50	Effective immediately	Stop setting	P
P05 06	Average filter time constant	0.0~128.0	ms	0.0	Effective immediately	Stop setting	P
P05 07	Electronic tooth ratio 1 (Molecules)	1~1073741824	-	1048576	Effective immediately	Run settings	P
P05 09	Electronic tooth ratio 1 (denominator)	1~1073741824	-	10000	Effective immediately	Run settings	P
P05 11	Electronic tooth ratio 2 (Molecules)	1~1073741824	-	1048576	Effective immediately	Run settings	P
P05 13	Electronic tooth ratio 2 (denominator)	1~1073741824	-	10000	Effective immediately	Run settings	P
P05 15	Pulse instruction pattern	0: pulse direction, positive logic 1: pulse direction, negative logic 2: A phase B phase orthogonal pulse ,4x frequency 3: CW CCW	-	0	Power up again	Stop setting	P
P05 16	Clear action selection	0: servo enable OFF and clearance	-	0	Effective	Stop	P

Function code	Name	Setting range	Unit	Factory setting	Effective way	Setting method	Related patterns
		of position deviation in case of failure Remove position deviation pulse 1: OFF of enable and failure 2: enable OFF and clear position deviation through DI input ClrPosErr signal			immediately	setting	
P05	17	Number of frequency division pulses	P/r	2500	Power up again	Stop setting	-
P05	19	Speed feedforward control selection	-	1	Effective immediately	Stop setting	P
P05	20	Location Complete Output Condition	-	0	Effective immediately	Run settings	P
P05	21	Location completion threshold	Encoder / Instruction Unit	734	Effective immediately	Run settings	P
P05	22	Positioning proximity threshold	Encoder / Instruction Unit	65535	Effective immediately	Run settings	P
P05	23	Interrupt fixed length enable	-	0	Power up again	Stop setting	P
P05	24	Interrupt long displacement	Instruction Unit	10000	Effective immediately	Run settings	P
P05	26	Constant length constant speed running speed	rpm	200	Effective immediately	Run settings	P
P05	27	Interrupt long acceleration and deceleration time	ms	10	Effective immediately	Run settings	P
P05	29	Fixed length lock release signal	-	1	Effective immediately	Run settings	P
P05	30	Origin Reversion Enable Control	-	0	Effective immediately	Run settings	P

Function code	Name	Setting range	Unit	Factory setting	Effective way	Setting method	Related patterns
		electrical return function Activate 3: origin immediately 4: immediate origin recovery 5: Activate Electrical Return Zero 6: origin at current position					
P05	31 Origin Recovery Mode	0: forward return zero, deceleration point, origin is origin switch 1: reverse return zero, deceleration point, origin is origin switch 2: forward return zero, deceleration point, origin is motor Z signal 3: reverse return zero, deceleration point, origin for motor Z signal 4: forward return zero, deceleration point is origin switch, origin is motor Z signal 5: reverse zero, deceleration point is origin switch, origin is motor Z signal 6: forward return zero, deceleration point, origin is forward overpass switch 7: reverse zero, deceleration point, origin is reverse overpass switch 8: forward return zero, deceleration point is forward overrun switch, origin is motor Z signal 9: reverse return zero, deceleration point is reverse overrun switch, origin is motor Z signal 10: forward to zero, deceleration point, origin is mechanical limit position 11: reverse return zero, deceleration point, origin is mechanical limit position 12: forward return zero, deceleration point is mechanical limit position, origin is motor Z signal 13: reverse zero, deceleration point is mechanical limit position, origin is motor Z signal	-	0	Effective immediately	Stop setting	P
P05	32 Speed of high-speed search for origin switch signal	0~3000	rpm	100	Effective immediately	Run settings	P
P05	33 Speed of low speed search for origin switch signal	0~1000	rpm	10	Effective immediately	Run settings	P
P05	34 Time of acceleration and deceleration when searching origin	0~1000	ms	1000	Effective immediately	Stop setting	P
P05	35 Limit the time to find the origin	0~65535	ms	10000	Effective immediately	Stop setting	P
P05	36 Mechanical origin offset	-1073741824 ~ 1073741824	Instruction unit	0	Effective immediately	Stop setting	P

Function code	Name	Setting range	Unit	Factory setting	Effective way	Setting method	Related patterns
P05 38	Servo Pulse Output Source Selection	0: encoder frequency division output 1: Pulse command synchronous output 2: frequency division or synchronous output prohibited	-	0	Power up again	Stop setting	P
P05 39	Electronic gear ratio switching conditions	0: position instruction (unit only) is 0 and switches after 2.5 m/s 1: real-time switching	-	0	Effective immediately	Stop setting	P
P05 40	Mechanical Origin Offset and Limit Treatment	0: P05-36 is the coordinate after the origin is returned, and the reverse origin is found 1: P05-36 is the relative offset after the origin is returned, and the reverse origin is found after the limit is triggered again to enable the origin to be returned 2: P05-36 is the origin after the return of the coordinates, encounter limit automatic reverse change 3: P05-36 is the relative offset after the origin is returned, the limit is automatically reversed	-	0	Effective immediately	Stop setting	P
P05 41	Z Pulse Output Polarity Selection	0: positive polarity output (Z pulse is high level) 1: negative output (Z pulse low level)	-	1	Power up again	Stop setting	P
P05 43	Position pulse along selection	Active on falling edge Active on rising edge	1	0	Power up again	Run settings	PST
P05 46	Absolute position linear mode position bias (low 32 bits)	-2147483648~2147483647	Encoder unit	0	Effective immediately	Stop setting	ALL
P05 48	Absolute position linear mode position bias (high 32 bits)	-2147483648~2147483647	Encoder unit	0	Effective immediately	Stop setting	ALL
P05 50	Absolute position rotation mode mechanical gear ratio (molecule)	1-65535	-	65535	Effective immediately	Stop setting	ALL
P05 51	Absolute position rotation mode mechanical gear ratio (denominator)	1-65535	-	1	Effective immediately	Stop setting	ALL
P05 52	Absolute position rotation mode load rotation cycle number of pulses (low 32 bits)	0~ 4294967295	Encoder unit	0	Effective immediately	Stop setting	ALL
P05 54	Absolute position rotation mode load rotation cycle number of pulses (32 bits high)	0~ 127	Encoder unit	0	Effective immediately	Stop setting	ALL
P05 56	Threshold of zero velocity judgment	0~1000	rpm	2	Effective immediately	Run settings	P
P05 58	Contact Stop Zero Torque Limit	0~300.0	%	100.0%	Effective immediately	Run settings	P
P05 59	Location Completion Window Time	0~30000	ms	1	Effective immediately	Run settings	P
P05 60	Positioning completion retention time	0~30000	ms	0	Effective immediately	Run settings	P

Function code	Name	Setting range	Unit	Factory setting	Effective way	Setting method	Related patterns
P05 61	Number of divider pulses (32 bits)	0~262143	P/r	0	Power up again	Stop setting	-

P06 Group Speed control parameters

Function code	Name	Setting range	Unit	Factory setting	Effective way	Setting method	Related patterns
P06 00	A Source of Main Speed Instruction	0: Number given (P06-03) 1:A11 2:A12	-	0	Effective immediately	Stop setting	S
P06 01	Auxiliary Speed Instruction B Source	0: Number given (P06-03) 1:A11 2:A12 3:0 (neutrality) 4:0 (neutrality) 5: Multi-segment speed instruction	-	1	Effective immediately	Stop setting	S
P06 02	Speed Instruction Selection	0: A Source of Main Speed Instruction 1: Auxiliary Speed Instruction B Source 2: A+B 3: A/B switch 4: Communications	-	0	Effective immediately	Stop setting	S
P06 03	Speed command keyboard setting	-6000~6000	rpm	200	Effective immediately	Run settings	S
P06 04	Set point speed	0~6000	rpm	100	Effective immediately	Run settings	S
P06 05	Speed command acceleration ramp time constant	0~65535	ms	0	Effective immediately	Run settings	S
P06 06	Speed command acceleration ramp time constant	0~65535	ms	0	Effective immediately	Run settings	S
P06 07	Maximum Speed Threshold	0~6000	rpm	6000	Effective immediately	Run settings	S
P06 08	Forward velocity threshold	0~6000	rpm	6000	Effective immediately	Run settings	S
P06 09	Reverse velocity threshold	0~6000	rpm	6000	Effective immediately	Run settings	S
P06 11	Torque Feedforward Control Selection	0: No torque feed 1: Internal torque feed	-	1	Effective immediately	Run settings	PS
P06 15	Zero fixed speed threshold	0~6000	rpm	10	Effective immediately	Run settings	S
P06 16	Motor rotation speed threshold	0~1000	rpm	20	Effective immediately	Run settings	S
P06 17	Speed consistent signal threshold	0~100	rpm	10	Effective immediately	Run settings	S
P06 18	Speed reaches signal threshold	10~6000	rpm	1000	Effective immediately	Run settings	S
P06 19	Zero speed output signal threshold	1~6000	rpm	10	Effective immediately	Run settings	S

P07 Group Torque control parameters

Torque instruction 100% corresponding to motor rated torque.

Function code	Name	Setting range	Unit	Factory setting	Effective way	Setting method	Related patterns
P07 00	A source of master torque instruction	0: Number given (P07-03) 1:A11 2:A12	-	0	Effective immediately	Stop setting	T
P07 01	Auxiliary torque	0: Number given (P07-03)	-	1	Effective	Stop	T

Function code	Name	Setting range	Unit	Factory setting	Effective way	Setting method	Related patterns
	instruction B source	1:A11 2:A12			immediately	setting	
P07 02	Torque Directive Selection	0: Source of main torque command A 1: Source of auxiliary torque command B 2: Source of main command A + source of auxiliary command B 3: Main command A source/auxiliary command B source switch 4: Communication setting	-	0	Effective immediately	Stop setting	T
P07 03	Torque instruction keyboard setting	-300.0~300.0	%	0	Effective immediately	Run settings	T
P07 05	Torque instruction filter time constant	0~30.00	ms	0.79	Effective immediately	Run settings	PST
P07 06	Second torque instruction filtering time constant	0~30.00	ms	0.79	Effective immediately	Run settings	PST
P07 07	Torque limitation sources	0: positive and negative internal torque limits 1: positive and negative external torque limits (using P-CL,N-CL options) 2: T-LMT used as external torque limit input 3: torque limit is the minimum value of positive and negative external torque and external T-LMT (using P-CL,N-CL selection) Switch between 4: positive and negative internal torque limit and T-LMT torque limit (using P-CL,N-CL selection)	-	0	Effective immediately	Stop setting	PST
P07 08	T-LMT selection	1: A11 2: A12	-	2	Effective immediately	Stop setting	PST
P07 09	Positive internal torque limit	0.0~300.0	%	300.0	Effective immediately	Run settings	PST
P07 10	Negative internal torque limit	0.0~300.0	%	300.0	Effective immediately	Run settings	PST
P07 11	Positive external torque limit	0.0~300.0	%	300.0	Effective immediately	Run settings	PST
P07 12	Negative External Torque Limit	0.0~300.0	%	300.0	Effective immediately	Run settings	PST
P07 17	Selection of speed limit sources	0: internal speed limits (Speed limit for torque control) 1: V-LMT used as an external speed limit input 2: select the P07-19/P07-20 as an internal speed limit via FunIN.36(V-SEL);	-	0	Effective immediately	Run settings	T
P07 18	V-LMT Selection	1: A11 2: A12	-	1	Effective immediately	Run settings	T
P07 19	Torque control forward speed limit value / torque control speed limit value 1	0~6000	rpm	3000	Effective immediately	Run settings	T
P07 20	Negative Speed Limit	0~6000	rpm	3000	Effective	Run	T

Function code	Name	Setting range	Unit	Factory setting	Effective way	Setting method	Related patterns
	for Torque Control / Speed Limit for Torque Control 2				immediately	settings	
P07	21 Torque reaches reference value	0.0~300.0	%	0.0	Effective immediately	Run settings	PST
P07	22 Torque reaches effective value	0.0~300.0	%	20.0	Effective immediately	Run settings	PST
P07	23 Torque arrives invalid	0.0~300.0	%	10.0	Effective immediately	Run settings	PST
P07	40 Speed restricted window in torque mode	0.5~30.0	ms	1.0	Effective immediately	Run settings	T

P08 Group Gain class parameters

Function code	Name	Setting range	Unit	Factory setting	Effective way	Setting method	Related patterns
P08	00 speed gain	0.1~2000.0	Hz	25.0	Effective immediately	Run settings	PS
P08	01 Speed loop integral time constant	0.15~512.00	ms	31.83	Effective immediately	Run settings	PS
P08	02 Position loop gain	0.0~2000.0	Hz	40.0	Effective immediately	Run settings	P
P08	03 Second speed loop gain	0.1~2000.0	Hz	40.0	Effective immediately	Run settings	PS
P08	04 No.2 Speed loop integral time constant	0.15~512.00	ms	40.00	Effective immediately	Run settings	PS
P08	05 No.2 Position loop gain	0.0~2000.0	Hz	64.0	Effective immediately	Run settings	P
P08	08 Second Gain Mode Settings	0: The first gain is fixed, and the external DI is used for P/PI switching; 1: Use gain switching according to the conditions of P08-09	-	1	Effective immediately	Run settings	PST
P08	09 Gain switching condition selection	0: The first gain is fixed (PS) 1: Use external DI switch (PS) 2: Torque command is large (PS) 3: Large speed command (PS) 4: Speed command change rate is large (PS) 5: Speed command high and low speed threshold (PS) 6: Large position deviation (P) 7: Position command (P) 8: Positioning completed (P) 9: The actual speed is large (P) 10: Position command + actual speed (P)	-	0	Effective immediately	Run settings	PST
P08	10 Gain switching delay time	0.0~1000.0	ms	5.0	Effective immediately	Run settings	PST
P08	11 Gain Switching Level	0~20000	According to switching conditions	50	Effective immediately	Run settings	PST
P08	12 Gain switching delay	0~20000	According to switching conditions	30	Effective immediately	Run settings	PST
P08	13 Position gain switching	0.0~1000.0	ms	3.0	Effective	Run	P

Function code	Name	Setting range	Unit	Factory setting	Effective way	Setting method	Related patterns
	time				immediately	settings	
P08 15	Load moment of inertia ratio	0.00~120.00	倍	1.00	Effective immediately	Run settings	PST
P08 18	Speed feed filter time constant	0.00~64.00	ms	0.50	Effective immediately	Run settings	P
P08 19	Speed feedforward gain	0.0~100.0	%	0.0	Effective immediately	Run settings	P
P08 20	Torque feed filter time constant	0.00~64.00	ms	0.50	Effective immediately	Stop setting	PS
P08 21	Torque Feedforward Gain	0.0~200.0	%	0.0	Effective immediately	Run settings	PS
P08 22	Speed Feedback Filter Option	0: Disable speed feedback average filtering 1: Speed feedback 2 times average filtering 2: Speed feedback 4 times average filtering 3: Speed feedback 8 times average filtering 4: Speed feedback 16 times average filtering	-	0	Effective immediately	Stop setting	PS
P08 23	Speed feedback low pass filter cutoff frequency	100~4000	Hz	4000	Effective immediately	Run settings	PS
P08 24	Pseudo-differential feedforward control coefficient	0.0~100.0	-	100.0	Effective immediately	Run settings	PS

P09 Group Self-adjusting parameters

Function code	Name	Setting range	Unit	Factory setting	Effective way	Setting method	Related patterns
P09 00	Self adjustment mode selection	0: parameter self-adjustment is invalid, manual adjustment of parameters 1: Parameter self-adjustment mode, use rigidity meter to automatically adjust gain parameters 2: Positioning mode, use rigidity meter to automatically adjust gain parameters	-	0	Effective immediately	Run settings	PST
P09 01	Rigid grade selection	0~31	-	12	Effective immediately	Run settings	PST
P09 02	Adaptive Trap Mode Selection	0: The adaptive notch filter is no longer updated 1: An adaptive notch filter is effective (the third group of notch filters) 2: An adaptive notch filter is effective (Group 3 and 4 notch filter) 3: Only test the resonance point, displayed on P09-24 4: Restore the values of the 3rd and 4th notch filters to the factory state	-	0	Effective immediately	Run settings	PST
P09 03	On-line Inertial Identification Mode	0: Disable online identification 1: Open online recognition, slowly changing 2: Open online identification, general changes	-	0	Effective immediately	Run settings	RST

Function code	Name	Setting range	Unit	Factory setting	Effective way	Setting method	Related patterns
		3: Open online recognition, rapid changes					
P09	04 Selection of Low Frequency Resonance Suppression Mode	0: Manually set the vibration frequency 1: Automatically identify the vibration frequency	-	0	Effective immediately	Run settings	P
P09	05 Offline Inertial Identification Mode Selection	0: Positive and negative triangle wave mode 1: JOG mode	-	0	Effective immediately	Stop setting	PST
P09	06 Maximum velocity for inertia identification	100~1000	rpm	500	Effective immediately	Stop setting	PST
P09	07 Acceleration to maximum velocity time constant for inertia identification	20~800	ms	125	Effective immediately	Stop setting	PST
P09	08 Waiting time after completion of single inertia identification	50~10000	ms	800	Effective immediately	Stop setting	PST
P09	09 Complete single inertia identification number of motor turns	0.00~2.00	r	-	-	Display	PST
P09	12 Group 1 Trap Frequency	50~4000	Hz	4000	Effective immediately	Run settings	PS
P09	13 Group 1 Trap width rating	0~20	-	2	Effective immediately	Run settings	PS
P09	14 Group 1 Trap depth rating	0~99	-	0	Effective immediately	Run settings	PS
P09	15 Group 2 Trap Frequency	50~4000	Hz	4000	Effective immediately	Run settings	PS
P09	16 Group 2 Trap width rating	0~20	-	2	Effective immediately	Run settings	PS
P09	17 Group 2 Trap depth rating	0~99	-	0	Effective immediately	Run settings	PS
P09	18 Group 3 Trap Frequency	50~4000	Hz	4000	Effective immediately	Run settings	PS
P09	19 Group 3 Trap width rating	0~20	-	2	Effective immediately	Run settings	PS
P09	20 Group 3 Trap depth rating	0~99	-	0	Effective immediately	Run settings	PS
P09	21 Group 4 Trap Frequency	50~4000	Hz	4000	Effective immediately	Run settings	PS
P09	22 Group 4 Trap width rating	0~20	-	2	Effective immediately	Run settings	PS
P09	23 Group 4 Trap depth rating	0~99	-	0	Effective immediately	Run settings	PS
P09	24 Resonance Frequency Identification Results	0~2	Hz	0	-	Display	PS
P09	30 Torque disturbance compensation gain	0.0~100.0	%	0.0	Effective immediately	Run settings	PS
P09	31 Time constant of torque disturbance observer filter	0.00~25.00	ms	0.50	Effective immediately	Run settings	PS
P09	38 Frequency resonance frequency	1.0~100.0	Hz	100.0	Effective immediately	Run settings	P
P09	39 Low Frequency Resonance Frequency Filter Setting	0~10	-	2	Effective immediately	Run settings	P

P0A Group Fault and Protection Parameters

Function code	Name	Setting range	Unit	Factory setting	Effective way	Setting method	Related patterns
P0A 00	Power Input Lack Protection Selection	0: Enable fault prohibit warning 1: Enable faults and warnings 2: Prohibit faults and warnings	-	0	Effective immediately	Run settings	-
P0A 03	Power-down save feature enables selection	0: Do not perform power-down save 1: Execute power-down save	-	0	Effective immediately	Run settings	-
P0A 04	Motor overload protection gain	50~300	%	100	Effective immediately	Stop setting	-
P0A 08	Failure threshold for overspeed	0~10000	rpm	0	Effective immediately	Run settings	PST
P0A 09	Maximum position pulse frequency	100~4000	kHz	4000	Effective immediately	Stop setting	P
P0A 10	Fault threshold with excessive position deviation	1 ~ 1073741824	Encoder unit/command unit	3145728	Effective immediately	Run settings	P
P0A 12	Vehicle protection features enable	0: No speed protection 1: Turn on speed protection	-	1	Effective immediately	Run settings	PST
P0A 16	Determination of Low Frequency Resonance Position Deviation	1-1000	Encoder unit	5	Effective immediately	Run settings	P
P0A 17	Location setting unit selection	0: Encoder unit 1: Command unit	-	0	Effective immediately	Stop setting	P
P0A 19	DI8 Filter time constant	0~255	25ns	80	Power up again	Stop setting	-
P0A 20	DI9 Filter time constant	0~255	25ns	80	Power up again	Stop setting	-
P0A 24	Filter Time of Low Speed Pulse Input Pin	0~255	25ns	30	Power up again	Stop setting	P
P0A 25	Velocity feedback display value filter time constant	0~5000	ms	50	Effective immediately	Stop setting	-
P0A 26	Motor overload shield enables	0: Open motor overload detection 1: shielding motor overload warning and fault detection	-	0	Effective immediately	Stop setting	-
P0A 27	Velocity DO filter time constant	0~5000	ms	10	Effective immediately	Stop setting	-
P0A 28	filter time constant of orthogonal encoder	0~255	25ns	30	Power up again	Stop setting	-
P0A 30	High speed pulse input pin filter time constant	0~255	25ns	3	Power up again	Stop setting	P
P0A 32	Time window for overtemperature protection	10~65535	ms	200	Effective immediately	Run settings	-
P0A 33	Overtemperature protection enables	0: Detection of Overtemperature Protection blocking of shielded motor 1: Monitoring of overtemperature protection for motor shutoff	-	1	Effective immediately	Run settings	-
P0A 36	Encoder Multiple Loop Overflow Fault	No shielding	-	0	Effective immediately	Stop setting	ALL

Function code	Name	Setting range	Unit	Factory setting	Effective way	Setting method	Related patterns
	Selection				ly		
P0A 40	Soft Limit Set	0: not soft limit 1: soft limit immediately after power on 2: soft limit after the origin is zero	1	0	Effective immediately	Stop setting	PST
P0A 41	Maximum Soft Limit	-2147483648~2147483647	Instruction unit	2147483647	Effective immediately	Stop setting	PST
P0A 43	Minimum Soft Limit Value	-2147483648~2147483647	Instruction unit	-2147483648	Effective immediately	Stop setting	PST
P0A 47	Lock protection test enables	0: No 1: Enable	-	1	Effective immediately	Run settings	ALL
P0A 48	Gravity Load Detection Value	0~300.0	%	30.0	Effective immediately	Run settings	ALL

P0B Group Monitoring parameters

Function code	Name	Setting range	Unit	Factory setting	Effective way	Setting method	Related patterns
P0B 00	Actual motor speed	-	rpm	-	-	Display	PST
P0B 01	Speed instruction	-	rpm	-	-	Display	PS
P0B 02	Internal torque instruction (relative to rated torque)	-	%	-	-	Display	PST
P0B 03	Input signal (DI signal) monitoring	-	-	-	-	Display	PST
P0B 05	Output signal (DO signal) monitoring	-	-	-	-	Display	PST
P0B 07	Absolute position counter (32-bit decimal display)	-	Instruction Unit	-	-	Display	PST
P0B 09	Mechanical angle (number of pulses starting at origin)	-	Encoder Unit	-	-	Display	PST
P0B 10	Electrical angle	-	°	-	-	Display	PST
P0B 11	Input position instruction corresponding speed information	-	rpm	-	-	Display	P
P0B 12	Average load rate	-	%	-	-	Display	PST
P0B 13	Input instruction pulse counter (32-bit decimal display)	-	Instruction Unit	-	-	Display	P
P0B 15	Encoder position deviation counter (32-bit decimal display)	-	Encoder Unit	-	-	Display	P
P0B 17	Feedback pulse counter (32-bit decimal display)	-	Encoder Unit	-	-	Display	PST
P0B 19	Total power-up time (32-bit decimal display)	-	s	-	-	Display	PST

Function code	Name	Setting range	Unit	Factory setting	Effective way	Setting method	Related patterns
P0B 21	All Sampling voltage values	-	V	-	-	Display	PST
P0B 22	All Sampling voltage values	-	V	-	-	Display	PST
P0B 24	Phase current RMS	-	A	-	-	Display	PST
P0B 26	Bus voltage	-	V	-	-	Display	PST
P0B 27	Module temperature values	-	°C	-	-	Display	PST
P0B 33	Failure logging	0: Current fault 1: Last 1 failure 2: Last 2 failure 9: Last 9 failures	-	0	Effective immediately	Run settings	PST
P0B 34	Number of failures selected	-	-	-	-	Display	PST
P0B 35	Selected fault timestamp	-	s	-	-	Display	PST
P0B 37	Motor speed at selected faults	-	rpm	-	-	Display	PST
P0B 38	Electrical U phase current at selected fault	-	A	-	-	Display	PST
P0B 39	Electrical V phase current at selected fault	-	A	-	-	Display	PST
P0B 40	Bus voltage at selected fault	-	V	-	-	Display	PST
P0B 41	Input terminal status at selected fault	-	-	-	-	Display	PST
P0B 42	Output terminal status at selected fault	-	-	-	-	Display	PST
P0B 53	Position Deviation Counter	-	Instruction Unit	-	-	Display	P
P0B 55	Actual motor speed(0.1rpm)	-	rpm	-	-	Display	PST
P0B 58	Mechanical absolute position (32 bits low)	-	Encoder Unit	0	-	Display	ALL
P0B 60	Mechanical absolute position (32 bits high)	-	Encoder Unit	0	-	Display	ALL
P0B 64	Real-time input position instruction counter	-	Unit of instruction	-	-	Display	PST
P0B 70	Absolute value encoder rotation circle data	-	r	0	-	Display	ALL
P0B 71	In-circle position of absolute encoder	-	Encoder Unit	0	-	Display	ALL
P0B 77	Absolute encoder absolute position (low 32 bits)	-	Encoder Unit	0	-	Display	ALL
P0B 79	Absolute encoder absolute position (high 32 bits)	-	Encoder Unit	0	-	Display	ALL
P0B 81	Rotating load single loop position (low 32 bits)	-	Encoder Unit	0	-	Display	ALL

Function code		Name	Setting range	Unit	Factory setting	Effective way	Setting method	Related patterns
P0B	83	Rotating load single loop position (high 32 bits)	-	Encoder Unit	0	-	Display	ALL
P0B	85	Rotating Load Single Circle Position	-	Unit of instruction	0	-	Display	ALL

P0C Group Communication parameters

Function code		Name	Setting range	Unit	Factory setting	Effective way	Setting method	Related patterns
P0C	00	Servo Axis Address	1~247, 0 for broadcast address	-	1	Effective immediately	Run settings	PST
P0C	02	Serial Port Rate Setup	0: 2400Kbp/s 1: 4800Kbp/s 2: 9600Kbp/s 3: 19200Kbp/s 4: 38400Kbp/s 5: 57600Kbp/s	-	2	Effective immediately	Run settings	PST
P0C	03	MODBUS data format	0: no check ,2 end bits 1: parity ,1 end bit 2: check ,1 end bit 3: no check ,1 end bit	-	3	Effective immediately	Run settings	PST
P0C	08	CAN Communication rate setting	0: 20K 3: 125K 6: 1M 1: 50K 4: 250K 7: 1M 2: 100K 5: 500K	-	5	Effective immediately	Run settings	PST
P0C	09	communicationVDI	Prohibition of enabling	-	0	Effective immediately	Stop setting	PST
P0C	10	VDI default value after power on	Bit0-VDI1 default values Bit15-VDI16 default values	-	0	Power up again	Run settings	PST
P0C	11	Communication VDO	0: prohibition 1: enabling	-	0	Effective immediately	Stop setting	PST
P0C	12	Default level when VDO function is selected as 0	Bit0-VDO1 default values Bit15-VDO16 default values	-	0	Effective immediately	Stop setting	PST
P0C	13	MODBUS communication write function code is updated to EEPROM	0: do not update EEPROM 1: update EEPROM except P0B and POD groups	-	1	Effective immediately	Run settings	PST
P0C	14	MODBUS Error code	New agreement: 0 x0001: Illegal function (command code) 0 x0002: Illegal data address 0 x0003: Illegal data 0 x0004: Station equipment malfunction Old Agreement: x0002: command code is not x03/0x06/0x10 0 0 x0004: Servo calculates that the CRC check code received by the data frame is not equal to the data frame check code 0 x0008: Access function code does not exist 0 x0010: Write the value of the function code beyond the upper and lower limits of the function code	1	-	-	Display	-

Function code	Name	Setting range	Unit	Factory setting	Effective way	Setting method	Related patterns
		0 x0080 : The written function code can only be modified in the servo shutdown state while the servo is currently in operation state					
P0C	16	CAN communication write function code is updated to EEPROM	-	0	Effective immediately	Run settings	PST
P0C	25	MODBUS Response Delay	ms	1	Effective immediately	Run settings	PST
P0C	26	MODBUS High-level Order of Communication Data	1	1	Effective immediately	Run settings	PST
P0C	30	MODBUS Error frame format selection	1	1	Effective immediately	Run settings	PST

P0D Group Auxiliary function parameters

Function code	Name	Setting range	Unit	Factory setting	Effective way	Setting method	Related patterns
P0D	00	Software Reset	-	0	Effective immediately	Stop setting	-
P0D	01	Fault reset	-	0	Effective immediately	Stop setting	-
P0D	02	Off-line Inertial Identification Function	-	-	Effective immediately	Run settings	-
P0D	03	Retention parameter	-	-	-	-	-
P0D	05	Emergency shut down	-	0	Effective immediately	Run settings	-
P0D	10	Automatic adjustment of analog channels	-	0	Effective immediately	Stop setting	-
P0D	11	JOG Test run function	-	-	-	-	-
P0D	17	DIDO Mandatory input and output enable	-	0	Effective immediately	Run settings	-
P0D	18	DI Mandatory input given	-	0x01FF	Effective immediately	Run settings	-
P0D	19	DO Forced output given	-	0	Effective immediately	Run settings	-
P0D	20	Absolute encoder reset enable	-	0	Effective immediately	Stop setting	ALL
P0D	24	Gravity Load Identification	-	0	Effective immediately	Run settings	-

P0F Group Full closed-loop functional parameters

Function code	Name	Setting range	Unit	Factory setting	Effective way	Setting method	Related patterns
P0F	00	Encoder Feedback Mode	-	0	Effective immediately	Stop setting	P
P0F	01	External Encoder	-	0	Effective	Stop	P

Function code	Name	Setting range	Unit	Factory setting	Effective way	Setting method	Related patterns
	Usage	1: used in reverse direction			immediately	setting	
P0F 04	Number of external encoder pulses rotated by motor	0 ~ 1073741824	External encoder Unit	10000	Power up again	Stop setting	P
P0F 08	Excessive threshold for full closed-loop position deviation	0 ~ 1073741824	External encoder Unit	10000	Effective immediately	Run settings	P
P0F 10	Full closed loop position deviation clearance setting	0~100	r	0	Effective immediately	Run settings	P
P0F 13	Mixed Vibration Suppression Filter Time Constant	0~6553.5	ms	0	Effective immediately	Run settings	P
P0F 16	Full closed loop position deviation counter	-1073741824 ~ 1073741824	External encoder Unit	0	-	Display	P
P0F 18	Internal encoder feedback pulse counter	-1073741824 ~ 1073741824	Internal encoder Unit	0	-	Display	P
P0F 20	External encoder feedback pulse counter	-1073741824 ~ 1073741824	External encoder Unit	0	-	Display	P

P11 Group Multi-segment position function parameter

Function code	Name	Setting range	Unit	Factory setting	Effective way	Setting method	Related patterns
P11 00	Multi-segment location operation mode	0: stop at the end of a single operation (P11-01 Select the number of segments) 1: Cyclic operation (P11-01 selects the number of segments) 2: DI switching operation (selected by DI) 3: Sequential operation (P11-01 for selection of segment number)	-	1	Effective immediately	Stop setting	P
P11 01	Number of terminal segments of displacement instruction	1~16	-	1	Effective immediately	Stop setting	P
P11 02	Residual treatment	Valid in the other three modes except DI mode 0: Continue to run the unfinished segment 1: Restart operation from the first segment	-	0	Effective immediately	Stop setting	P
P11 03	Time unit	0: ms 1: s	-	0	Effective immediately	Stop setting	P
P11 04	Type of displacement instruction	0: Relative displacement command 1: Absolute displacement instruction	-	0	Effective immediately	Stop setting	P
P11 05	Sequence Run Start Select	0~16	-	0	Effective immediately	Stop setting	P
P11 12	Paragraph 1 moving displacement	-1073741824 ~ 1073741824	instruction unit	10000	Effective immediately	Run settings	P

Function code	Name	Setting range	Unit	Factory setting	Effective way	Setting method	Related patterns
P11 14	Maximum speed of displacement in section 1	1~6000	rpm	200	Effective immediately	Run settings	P
P11 15	Paragraph 1 displacement acceleration and deceleration time	0~65535	ms(s)	10	Effective immediately	Run settings	P
P11 16	Paragraph 1 displacement acceleration and deceleration time	0~10000	ms(s)	10	Effective immediately	Run settings	P
P11 17	Paragraph 2 moving displacement	-1073741824 ~ 1073741824	instruction unit	10000	Effective immediately	Run settings	P
P11 19	Maximum speed of displacement in section 2	1~6000	rpm	200	Effective immediately	Run settings	P
P11 20	Paragraph 2 displacement acceleration and deceleration time	0~65535	ms(s)	10	Effective immediately	Run settings	P
P11 21	Waiting time after completion of displacement in paragraph 2	0~10000	ms(s)	10	Effective immediately	Run settings	P
P11 22	Paragraph 3 moving displacement	-1073741824 ~ 1073741824	instruction unit	10000	Effective immediately	Run settings	P
P11 24	Maximum speed of displacement in section 3	1~6000	rpm	200	Effective immediately	Run settings	P
P11 25	Paragraph 3 displacement acceleration and deceleration time	0~65535	ms(s)	10	Effective immediately	Run settings	P
P11 26	Waiting time after completion of displacement in paragraph 3	0~10000	ms(s)	10	Effective immediately	Run settings	P
P11 27	Paragraph 4 moving displacement	-1073741824 ~ 1073741824	instruction unit	10000	Effective immediately	Run settings	P
P11 29	Maximum speed of displacement in section 4	1~6000	rpm	200	Effective immediately	Run settings	P
P11 30	Paragraph 4 displacement acceleration and deceleration time	0~65535	ms(s)	10	Effective immediately	Run settings	P
P11 31	Waiting time after completion of displacement in paragraph 4	0~10000	ms(s)	10	Effective immediately	Run settings	P
P11 32	Paragraph 5 moving displacement	-1073741824 ~ 1073741824	instruction unit	10000	Effective immediately	Run settings	P

Function code	Name	Setting range	Unit	Factory setting	Effective way	Setting method	Related patterns
P11 34	Maximum speed of displacement in section 5	1~6000	rpm	200	Effective immediately	Run settings	P
P11 35	Paragraph 5 displacement acceleration and deceleration time	0~65535	ms(s)	10	Effective immediately	Run settings	P
P11 36	Waiting time after completion of displacement in paragraph 5	0~10000	ms(s)	10	Effective immediately	Run settings	P
P11 37	Paragraph 6 moving displacement	-1073741824 ~ 1073741824	Instructions	10000	Effective immediately	Run settings	P
P11 39	Maximum speed of displacement in section 6	1~6000	rpm	200	Effective immediately	Run settings	P
P11 40	Paragraph 6 displacement acceleration and deceleration time	0~65535	ms(s)	10	Effective immediately	Run settings	P
P11 41	Waiting time after completion of displacement in paragraph 6	0~10000	ms(s)	10	Effective immediately	Run settings	P
P11 42	Paragraph 7 moving displacement	-1073741824 ~ 1073741824	instruction unit	10000	Effective immediately	Run settings	P
P11 44	Maximum speed of displacement in section 7	1~6000	rpm	200	Effective immediately	Run settings	P
P11 45	Paragraph 7 displacement acceleration and deceleration time	0~65535	ms(s)	10	Effective immediately	Run settings	P
P11 46	Waiting time after completion of displacement in paragraph 7	0~10000	ms(s)	10	Effective immediately	Run settings	P
P11 47	Paragraph 8 moving displacement	-1073741824 ~ 1073741824	Instructions	10000	Effective immediately	Run settings	P
P11 49	Maximum speed of displacement in section 8	1~6000	rpm	200	Effective immediately	Run settings	P
P11 50	Paragraph 8 displacement acceleration and deceleration time	0~65535	ms(s)	10	Effective immediately	Run settings	P
P11 51	Waiting time after completion of displacement in paragraph 8	0~10000	ms(s)	10	Effective immediately	Run settings	P
P11 52	Paragraph 9 moving displacement	-1073741824 ~ 1073741824	instruction unit	10000	Effective immediately	Run settings	P

Function code	Name	Setting range	Unit	Factory setting	Effective way	Setting method	Related patterns
P11 54	Maximum speed of displacement in section 9	1~6000	rpm	200	Effective immediately	Run settings	P
P11 55	Paragraph 9 displacement acceleration and deceleration time	0~65535	ms(s)	10	Effective immediately	Run settings	P
P11 56	Waiting time after completion of displacement in paragraph 9	0~10000	ms(s)	10	Effective immediately	Run settings	P
P11 57	Paragraph 10 moving displacement	-1073741824 ~ 1073741824	Instructions	10000	Effective immediately	Run settings	P
P11 59	Maximum speed of displacement in section 10	1~6000	rpm	200	Effective immediately	Run settings	P
P11 60	Paragraph 10 displacement acceleration and deceleration time	0~65535	ms(s)	10	Effective immediately	Run settings	P
P11 61	Waiting time after completion of displacement in paragraph 10	0~10000	ms(s)	10	Effective immediately	Run settings	P
P11 62	Paragraph 11 moving displacement	-1073741824 ~ 1073741824	Instructions	10000	Effective immediately	Run settings	P
P11 64	Maximum speed of displacement in section 11	1~6000	rpm	200	Effective immediately	Run settings	P
P11 65	Paragraph 11 displacement acceleration and deceleration time	0~65535	ms(s)	10	Effective immediately	Run settings	P
P11 66	Waiting time after completion of displacement in paragraph 11	0~10000	ms(s)	10	Effective immediately	Run settings	P
P11 67	Paragraph 12 moving displacement	-1073741824 ~ 1073741824	Instructions	10000	Effective immediately	Run settings	P
P11 69	Maximum speed of displacement in section 12	1~6000	rpm	200	Effective immediately	Run settings	P
P11 70	Paragraph 12 displacement acceleration and deceleration time	0~65535	ms(s)	10	Effective immediately	Run settings	P
P11 71	Waiting time after completion of displacement in paragraph 12	0~10000	ms(s)	10	Effective immediately	Run settings	P
P11 72	Paragraph 13 moving displacement	-1073741824 ~ 1073741824	Instructions	10000	Effective immediately	Run settings	P

Function code	Name	Setting range	Unit	Factory setting	Effective way	Setting method	Related patterns
P11 74	Maximum speed of displacement in section 13	1~6000	rpm	200	Effective immediately	Run settings	P
P11 75	Paragraph 13 displacement acceleration and deceleration time	0~65535	ms(s)	10	Effective immediately	Run settings	P
P11 76	Waiting time after completion of displacement in paragraph 13	0~10000	ms(s)	10	Effective immediately	Run settings	P
P11 77	Paragraph 14 moving displacement	-1073741824 ~ 1073741824	Instruction Unit	10000	Effective immediately	Run settings	P
P11 79	Maximum speed of displacement in section 14	1~6000	rpm	200	Effective immediately	Run settings	P
P11 80	Paragraph 14 displacement acceleration and deceleration time	0~65535	ms(s)	10	Effective immediately	Run settings	P
P11 81	Waiting time after completion of displacement in paragraph 14	0~10000	ms(s)	10	Effective immediately	Run settings	P
P11 82	Paragraph 15 moving displacement	-1073741824 ~ 1073741824	Instruction Unit	10000	Effective immediately	Run settings	P
P11 84	Maximum speed of displacement in section 15	1~6000	rpm	200	Effective immediately	Run settings	P
P11 85	Paragraph 15 displacement acceleration and deceleration time	0~65535	ms(s)	10	Effective immediately	Run settings	P
P11 86	Waiting time after completion of displacement in paragraph 15	0~10000	ms(s)	10	Effective immediately	Run settings	P
P11 87	Paragraph 16 moving displacement	-1073741824 ~ 1073741824	Instruction Unit	10000	Effective immediately	Run settings	P
P11 89	Maximum speed of displacement in section 16	1~6000	rpm	200	Effective immediately	Run settings	P
P11 90	Paragraph 16 displacement acceleration and deceleration time	0~65535	ms(s)	10	Effective immediately	Run settings	P
P11 91	Waiting time after completion of displacement in paragraph 16	0~10000	ms(s)	10	Effective immediately	Run settings	P

P12 Group Multi-segment speed parameter

Function code	Name	Setting range	Unit	Factory setting	Effective way	Setting method	Related patterns
P12 00	Multi-segment speed instruction running mode	0: stop at the end of a single operation (P12-01 Select the number of segments) 1: Cyclic operation (P12-01 selects the number of segments) 2: Switch through external DI	-	1	Effective immediately	Stop setting	S
P12 01	Selection of terminal segments of speed instruction	1~16	-	16	Effective immediately	Stop setting	S
P12 02	Runtime unit selection	0-sec-1-min	-	0	Effective immediately	Stop setting	S
P12 03	Acceleration time 1	0~65535	ms	10	Effective immediately	Stop setting	S
P12 04	Deceleration time 1	0~65535	ms	10	Effective immediately	Stop setting	S
P12 05	Acceleration time 2	0~65535	ms	50	Effective immediately	Stop setting	S
P12 06	Deceleration time 2	0~65535	ms	50	Effective immediately	Stop setting	S
P12 07	Acceleration time 3	0~65535	ms	100	Effective immediately	Stop setting	S
P12 08	Deceleration time3	0~65535	ms	100	Effective immediately	Stop setting	S
P12 09	Acceleration time 4	0~65535	ms	150	Effective immediately	Stop setting	S
P12 10	Deceleration time 4	0~65535	ms	150	Effective immediately	Stop setting	S
P12 20	Paragraph 1 Speed Directive	-6000~6000	rpm	0	Effective immediately	Stop setting	S
P12 21	Paragraph 1 instruction run time	0~6553.5	S (min)	5.0	Effective immediately	Stop setting	S
P12 22	Paragraph 1 Acceleration and deceleration	0: Zero acceleration and deceleration time 1: Acceleration and deceleration time 1 2: Acceleration and deceleration time 2 3: Acceleration and deceleration time 3 4: Acceleration and deceleration time 4	-	0	Effective immediately	Stop setting	S
P12 23	Paragraph 2 Speed Directive	-6000~6000	rpm	100	Effective immediately	Stop setting	S
P12 24	Paragraph 2 instruction run time	0~6553.5	S (min)	5.0	Effective immediately	Stop setting	S
P12 25	Paragraph 2	0: Zero acceleration and deceleration time	-	0	Effective	Stop	S

Function code	Name	Setting range	Unit	Factory setting	Effective way	Setting method	Related patterns
	Acceleration and deceleration	1: Acceleration and deceleration time 1 2: Acceleration and deceleration time 2 3: Acceleration and deceleration time 3 4: Acceleration and deceleration time 4			immediately	setting	
P12	26 Paragraph 3 Speed Directive	-6000~6000	rpm	300	Effective immediately	Stop setting	S
P12	27 Paragraph 3 instruction run time	0~6553.5	S (min)	5.0	Effective immediately	Stop setting	S
P12	28 Paragraph 3 Acceleration and deceleration	0: Zero acceleration and deceleration time 1: Acceleration and deceleration time 1 2: Acceleration and deceleration time 2 3: Acceleration and deceleration time 3 4: Acceleration and deceleration time 4	-	0	Effective immediately	Stop setting	S
P12	29 Paragraph 4 Speed Directive	-6000~6000	rpm	500	Effective immediately	Stop setting	S
P12	30 Paragraph 4 instruction run time	0~6553.5	S (min)	5.0	Effective immediately	Stop setting	S
P12	31 Paragraph 4 Acceleration and deceleration	0: Zero acceleration and deceleration time 1: Acceleration and deceleration time 1 2: Acceleration and deceleration time 2 3: Acceleration and deceleration time 3 4: Acceleration and deceleration time 4	-	0	Effective immediately	Stop setting	S
P12	32 Paragraph 5 Speed Directive	-6000~6000	rpm	700	Effective immediately	Stop setting	S
P12	33 Paragraph 5 instruction run time	0~6553.5	S (min)	5.0	Effective immediately	Stop setting	S
P12	34 Paragraph 5 Acceleration and deceleration	0: Zero acceleration and deceleration time 1: Acceleration and deceleration time 1 2: Acceleration and deceleration time 2 3: Acceleration and deceleration time 3 4: Acceleration and deceleration time 4	-	0	Effective immediately	Stop setting	S
P12	35 Paragraph 6 Speed Directive	-6000~6000	rpm	900	Effective immediately	Stop setting	S
P12	36 Paragraph 6 instruction run time	0~6553.5	S (min)	5.0	Effective immediately	Stop setting	S
P12	37 Paragraph 6 Acceleration and deceleration	0: Zero acceleration and deceleration time 1: Acceleration and deceleration time 1 2: Acceleration and deceleration time 2 3: Acceleration and deceleration time 3 4: Acceleration and deceleration time 4	-	0	Effective immediately	Stop setting	S
P12	38 Paragraph 7 Speed Directive	-6000~6000	rpm	600	Effective immediately	Stop setting	S
P12	39 Paragraph 7 instruction	0~6553.5	S	5.0	Effective	Stop	S

Function code	Name	Setting range	Unit	Factory setting	Effective way	Setting method	Related patterns
	run time		(min)		immediately	setting	
P12 40	Paragraph 7 Acceleration and deceleration	0: Zero acceleration and deceleration time 1: Acceleration and deceleration time 1 2: Acceleration and deceleration time 2 3: Acceleration and deceleration time 3 4: Acceleration and deceleration time 4	-	0	Effective immediately	Stop setting	S
P12 41	Paragraph 8 Speed Directive	-6000~6000	rpm	300	Effective immediately	Stop setting	S
P12 42	Paragraph 8 instruction run time	0~6553.5	S (min)	5.0	Effective immediately	Stop setting	S
P12 43	Paragraph 8 Acceleration and deceleration	0: Zero acceleration and deceleration time 1: Acceleration and deceleration time 1 2: Acceleration and deceleration time 2 3: Acceleration and deceleration time 3 4: Acceleration and deceleration time 4	-	0	Effective immediately	Stop setting	S
P12 44	Paragraph 9 Speed Directive	-6000~6000	rpm	100	Effective immediately	Stop setting	S
P12 45	Paragraph 9 instruction run time	0~6553.5	S (min)	5.0	Effective immediately	Stop setting	S
P12 46	Paragraph 9 Acceleration and deceleration	0: Zero acceleration and deceleration time 1: Acceleration and deceleration time 1 2: Acceleration and deceleration time 2 3: Acceleration and deceleration time 3 4: Acceleration and deceleration time 4	-	0	Effective immediately	Stop setting	S
P12 47	Paragraph 10 Speed Directive	-6000~6000	rpm	-100	Effective immediately	Stop setting	S
P12 48	Paragraph 10 instruction run time	0~6553.5	S (min)	5.0	Effective immediately	Stop setting	S
P12 49	Paragraph 10 Acceleration and deceleration	0: Zero acceleration and deceleration time 1: Acceleration and deceleration time 1 2: Acceleration and deceleration time 2 3: Acceleration and deceleration time 3 4: Acceleration and deceleration time 4	-	0	Effective immediately	Stop setting	S
P12 50	Paragraph 11 Speed Directive	-6000~6000	rpm	-300	Effective immediately	Stop setting	S
P12 51	Paragraph 11 instruction run time	0~6553.5	S (min)	5.0	Effective immediately	Stop setting	S
P12 52	Paragraph 11 Acceleration and deceleration	0: Zero acceleration and deceleration time 1: Acceleration and deceleration time 1 2: Acceleration and deceleration time 2 3: Acceleration and deceleration time 3 4: Acceleration and deceleration time 4	-	0	Effective immediately	Stop setting	S
P12 53	Paragraph 12 Speed	-6000~6000	rpm	-500	Effective	Stop	S

Function code	Name	Setting range	Unit	Factory setting	Effective way	Setting method	Related patterns
	Directive				immediately	setting	
P12	54 Paragraph 12 instruction run time	0~6553.5	S (min)	5.0	Effective immediately	Stop setting	S
P12	55 Paragraph 12 Acceleration and deceleration	0: Zero acceleration and deceleration time 1: Acceleration and deceleration time 1 2: Acceleration and deceleration time 2 3: Acceleration and deceleration time 3 4: Acceleration and deceleration time 4	-	0	Effective immediately	Stop setting	S
P12	56 Paragraph 13 Speed Directive	-6000~6000	rpm	-700	Effective immediately	Stop setting	S
P12	57 Paragraph 13 instruction run time	0~6553.5	S (min)	5.0	Effective immediately	Stop setting	S
P12	58 Paragraph 13 Acceleration and deceleration	0: Zero acceleration and deceleration time 1: Acceleration and deceleration time 1 2: Acceleration and deceleration time 2 3: Acceleration and deceleration time 3 4: Acceleration and deceleration time 4	-	0	Effective immediately	Stop setting	S
P12	59 Paragraph 14 Speed Directive	-6000~6000	rpm	-900	Effective immediately	Stop setting	S
P12	60 Paragraph 14 instruction run time	0~6553.5	S (min)	5.0	Effective immediately	Stop setting	S
P12	61 Paragraph 14 Acceleration and deceleration	0: Zero acceleration and deceleration time 1: Acceleration and deceleration time 1 2: Acceleration and deceleration time 2 3: Acceleration and deceleration time 3 4: Acceleration and deceleration time 4	-	0	Effective immediately	Stop setting	S
P12	62 Paragraph 15 Speed Directive	-6000~6000	rpm	-600	Effective immediately	Stop setting	S
P12	63 Paragraph 15 instruction run time	0~6553.5	S (min)	5.0	Effective immediately	Stop setting	S
P12	64 Paragraph 15 Acceleration and deceleration	0: Zero acceleration and deceleration time 1: Acceleration and deceleration time 1 2: Acceleration and deceleration time 2 3: Acceleration and deceleration time 3 4: Acceleration and deceleration time 4	-	0	Effective immediately	Stop setting	S
P12	65 Paragraph 16 Speed Directive	-6000~6000	rpm	-300	Effective immediately	Stop setting	S
P12	66 Paragraph 16 instruction run time	0~6553.5	S (min)	5.0	Effective immediately	Stop setting	S
P12	67 Paragraph 16. Acceleration and deceleration	0: Zero acceleration and deceleration time 1: Acceleration and deceleration time 1 2: Acceleration and deceleration time 2	-	0	Effective immediately	Stop setting	S

Function code	Name	Setting range	Unit	Factory setting	Effective way	Setting method	Related patterns
		3: Acceleration and deceleration time 3 4: Acceleration and deceleration time 4					

P17 Group Virtual DIDO parameters

Function code	Name	Setting range	Unit	Factory setting	Effective way	Setting method	Related patterns
P17 00	VDI1 Terminal function selection	0~37	-	0	Outage takes effect	Run settings	-
P17 01	VDI1 Terminal logic selection	0: indicates VDI1 write 1 is valid 1: indicates that VDI1 write value changes from 0 to 1	-	0	Outage takes effect	Run settings	-
P17 02	VDI2 Terminal function selection	0~37	-	0	Outage takes effect	Run settings	-
P17 03	VDI2 Terminal logic selection	0: indicates VDI2 write 1 is valid 1: indicates that VDI2 write value changes from 0 to 1	-	0	Outage takes effect	Run settings	-
P17 04	VDI3 Terminal function selection	0~37	-	0	Outage takes effect	Run settings	-
P17 05	VDI3 Terminal logic selection	0: indicates VDI3 write 1 is valid 1: indicates that VDI3 write value changes from 0 to 1	-	0	Outage takes effect	Run settings	-
P17 06	VDI4 Terminal function selection	0~37	-	0	Outage takes effect	Run settings	-
P17 07	VDI4 Terminal logic selection	0: indicates VDI4 write 1 is valid 1: indicates that VDI4 write value changes from 0 to 1	-	0	Outage takes effect	Run settings	-
P17 08	VDI5 Terminal function selection	0~37	-	0	Outage takes effect	Run settings	-
P17 09	VDI5 Terminal logic selection	0: indicates VDI5 write 1 is valid 1: indicates that VDI5 write value changes from 0 to 1	-	0	Outage takes effect	Run settings	-
P17 10	VDI6 Terminal function selection	0~37	-	0	Outage takes effect	Run settings	-
P17 11	VDI6 Terminal logic selection	0: indicates VDI6 write 1 is valid 1: indicates that VDI6 write value changes from 0 to 1	-	0	Outage takes effect	Run settings	-
P17 12	VDI7 Terminal function selection	0~37	-	0	Outage takes effect	Run settings	-
P17 13	VDI7 Terminal logic selection	0: indicates VDI7 write 1 is valid 1: indicates that VDI7 write value changes from 0 to 1	-	0	Outage takes effect	Run settings	-
P17 14	VDI8 Terminal function selection	0~37	-	0	Outage takes effect	Run settings	-
P17 15	VDI8 Terminal logic selection	0: indicates VDI8 write 1 is valid 1: indicates that VDI8 write value changes from 0 to 1	-	0	Outage takes effect	Run settings	-
P17 16	VDI9 Terminal function selection	0~37	-	0	Outage takes effect	Run settings	-
P17 17	VDI9 Terminal logic selection	0: indicates VDI9 write 1 is valid 1: indicates that VDI9 write value changes from 0 to 1	-	0	Outage takes effect	Run settings	-
P17 18	VDI10 Terminal	0~37	-	0	Outage	Run	-

Function code	Name	Setting range	Unit	Factory setting	Effective way	Setting method	Related patterns
	function selection				takes effect	settings	
P17 19	VDI10 Terminal logic selection	0: indicates VDI10 write 1 is valid 1: indicates that VDI10 write value changes from 0 to 1	-	0	Outage takes effect	Run settings	-
P17 20	VDI11 Terminal function selection	0~37	-	0	Outage takes effect	Run settings	-
P17 21	VDI11 Terminal logic selection	0: indicates VDI11 write 1 is valid 1: indicates that VDI11 write value changes from 0 to 1	-	0	Outage takes effect	Run settings	-
P17 22	VDI12 Terminal function selection	0~37	-	0	Outage takes effect	Run settings	-
P17 23	VDI12 Terminal logic selection	0: indicates VDI12 write 1 is valid 1: indicates that VDI12 write value changes from 0 to 1	-	0	Outage takes effect	Run settings	-
P17 24	VDI13 Terminal function selection	0~37	-	0	Outage takes effect	Run settings	-
P17 25	VDI13 Terminal logic selection	0: indicates VDI13 write 1 is valid 1: indicates that VDI13 write value changes from 0 to 1	-	0	Outage takes effect	Run settings	-
P17 26	VDI14 Terminal function selection	0~37	-	0	Outage takes effect	Run settings	-
P17 27	VDI14 Terminal logic selection	0: indicates VDI14 write 1 is valid 1: indicates that VDI14 write value changes from 0 to 1	-	0	Outage takes effect	Run settings	-
P17 28	VDI15 Terminal function selection	0~37	-	0	Outage takes effect	Run settings	-
P17 29	VDI15 Terminal logic selection	0: indicates VDI14 write 1 is valid 1: indicates that VDI14 write value changes from 0 to 1	-	0	Outage takes effect	Run settings	-
P17 30	VDI16 Terminal function selection	0~37	-	0	Outage takes effect	Run settings	-
P17 31	VDI16 Terminal logic selection	0: indicates VDI16 write 1 is valid 1: indicates that VDI16 write value changes from 0 to 1	-	0	Outage takes effect	Run settings	-
P17 32	VDO Virtual level	-	-	-	-	Display	-
P17 33	VDO1 Terminal function selection	0~22	-	0	Outage takes effect	Run settings	-
P17 34	VDO1 Terminal logic selection	0: means valid output 1 1: means valid output 0	-	0	Outage takes effect	Run settings	-
P17 35	VDO2 Terminal function selection	0~22	-	0	Outage takes effect	Run settings	-
P17 36	VDO2 Terminal logic selection	0: means valid output 1 1: means valid output 0	-	0	Outage takes effect	Run settings	-
P17 37	VDO3 Terminal function selection	0~22	-	0	Outage takes effect	Run settings	-
P17 38	VDO3 Terminal logic selection	0: means valid output 1 1: means valid output 0	-	0	Outage takes effect	Run settings	-
P17 39	VDO4 Terminal function selection	0~22	-	0	Outage takes effect	Run settings	-
P17 40	VDO4 Terminal logic selection	0: means valid output 1 1: means valid output 0	-	0	Outage takes effect	Run settings	-
P17 41	VDO5 Terminal function selection	0~22	-	0	Outage takes effect	Run settings	-
P17 42	VDO5 Terminal logic	0: means valid output 1	-	0	Outage	Run	-

Function code	Name	Setting range	Unit	Factory setting	Effective way	Setting method	Related patterns
	selection	1: means valid output 0			takes effect	settings	
P17 43	VDO6 Terminal function selection	0~22	-	0	Outage takes effect	Run settings	-
P17 44	VDO6 Terminal logic selection	0: means valid output 1 1: means valid output 0	-	0	Outage takes effect	Run settings	-
P17 45	VDO7 Terminal function selection	0~22	-	0	Outage takes effect	Run settings	-
P17 46	VDO7 Terminal logic selection	0: means valid output 1 1: means valid output 0	-	0	Outage takes effect	Run settings	-
P17 47	VDO8 Terminal function selection	0~22	-	0	Outage takes effect	Run settings	-
P17 48	VDO8 Terminal logic selection	0: means valid output 1 1: means valid output 0	-	0	Outage takes effect	Run settings	-
P17 49	VDO9 Terminal function selection	0~22	-	0	Outage takes effect	Run settings	-
P17 50	VDO9 Terminal logic selection	0: means valid output 1 1: means valid output 0	-	0	Outage takes effect	Run settings	-
P17 51	VDO10 Terminal function selection	0~22	-	0	Outage takes effect	Run settings	-
P17 52	VDO10 Terminal logic selection	0: means valid output 1 1: means valid output 0	-	0	Outage takes effect	Run settings	-
P17 53	VDO11 Terminal function selection	0~22	-	0	Outage takes effect	Run settings	-
P17 54	VDO11 Terminal logic selection	0: means valid output 1 1: means valid output 0	-	0	Outage takes effect	Run settings	-
P17 55	VDO12 Terminal function selection	0~22	-	0	Outage takes effect	Run settings	-
P17 56	VDO12 Terminal logic selection	0: means valid output 1 1: means valid output 0	-	0	Outage takes effect	Run settings	-
P17 57	VDO13 Terminal function selection	0~22	-	0	Outage takes effect	Run settings	-
P17 58	VDO13 Terminal logic selection	0: means valid output 1 1: means valid output 0	-	0	Outage takes effect	Run settings	-
P17 59	VDO14 Terminal function selection	0~22	-	0	Outage takes effect	Run settings	-
P17 60	VDO14 Terminal logic selection	0: means valid output 1 1: means valid output 0	-	0	Outage takes effect	Run settings	-
P17 61	VDO15 Terminal function selection	0~22	-	0	Outage takes effect	Run settings	-
P17 62	VDO15 Terminal logic selection	0: means valid output 1 1: means valid output 0	-	0	Outage takes effect	Run settings	-
P17 63	VDO16 Terminal function selection	0~22	-	0	Outage takes effect	Run settings	-
P17 64	VDO16 Terminal logic selection	0: means valid output 1 1: means valid output 0	-	0	Outage takes effect	Run settings	-

P30 Group Communication read servo-related variables

Panel invisible

Function code	Name	Setting range	Unit	Factory setting	Effective way	Setting method	Related patterns
P30 00	Communications read servo state	-	-	-	-	Communication read only	PST
P30 01	Communication Read DO	-	-	-	-	Communication	PST

Function code	Name	Setting range	Unit	Factory setting	Effective way	Setting method	Related patterns
	Function Status 1					read only	
P30 02	Communication Read DO Function 2	-	-	-	-	Communication read only	PST
P30 03	Communication readinput pulse instructionsampling	-	-	-	-	Display	PST

P31GroupCommunication gives servo-related variables
Panel invisible

Function code	Name	Setting range	Unit	Factory setting	Effective way	Setting method	Related patterns
P31 00	Communication given VDI virtual level	0~65535	-	0	Effective immediately	Run settings	PST
P31 04	Communication given DO output state	0~31	-	0	Effective immediately	Run settings	PST
P31 09	Communication Given Speed Command	-6000.000~6000.000	rpm	0	Effective immediately	Run settings	S
P31 11	Communication given torque instruction	-100.000~100.000	%	0	Effective immediately	Run settings	T

DIDO Function definition

Code	Name	Function	Description	Notes
Enter the signal function instructions				
FunIN.1	S-ON	Servo Enable	Invalid - Servo motor disable; Effective - Servo motor power on.	The logical selection of the corresponding terminal must be set to: level valid. When the corresponding DI or VDI terminal of this function changes, or when the logic selection of the corresponding terminal changes, the change needs to be electrified again before the change takes effect.
FunIN.2	ALM-RST	Failure and warning reset (along effective function)	Invalid - Servo motor disable; Effective - Servo motor power on.	The logical selection of the corresponding terminal must be set to: edge valid. If the selection level is valid, the drive internal force is set to edge valid. According to the alarm type, some alarm reset servo can continue to work.
FunIN.3	GAIN-SEL	Gain switching	When P08-08=0 : Invalid-speed control loop for PI control; Effective-speed control ring for P control. When P08-08=1, press the P08-09 settings.	The logic selection of the corresponding terminal is recommended to be set to: level effective.
FunIN.4	CMD-SEL	Switching of Mainand Auxiliary Operation Instruction	Invalid - the current running instruction is A; Valid - the current running instruction is B.	The logic selection of the corresponding terminal is recommended to be set to: level effective.
FunIN.5	DIR-SEL	Multi-segment speed DI switching operation direction setting	Invalid - default instruction direction; Valid - instruction in reverse direction.	The logic selection of the corresponding terminal is recommended to be set to: level effective.

Code	Name	Function	Description	Notes
FunIN.6	CMD1	Multi-segment running instruction switch 1	16 instruction selection	The logic selection of the corresponding terminal is recommended to be set to: level effective.
FunIN.7	CMD2	Multi-segment operation instruction switch 2	16 instruction selection	The logic selection of the corresponding terminal is recommended to be set to: level effective.
FunIN.8	CMD3	Multi-segment running instruction switch 3	16 instruction selection	The logic selection of the corresponding terminal is recommended to be set to: level effective.
FunIN.9	CMD4	Multi-segment operation instruction switching 4	16 instruction selection	The logic selection of the corresponding terminal is recommended to be set to: level effective.
FunIN.10	M1-SEL	Mode switching 1	According to the selected control mode (3,4,5),switch between speed, position, torque	The logic selection of the corresponding terminal is recommended to be set to: level effective.
FunIN.11	M2-SEL	Mode switching 2	According to the selected control mode (6), switch between speed, position, torque.	The logic selection of the corresponding terminal is recommended to be set to: level effective.
FunIN.12	ZCLAMP	Zero-position fixed enable	Effective - enable zero-bit fixed function; Invalid-Nozero-bit fixing function.	The logic selection of the corresponding terminal is recommended to be set to: level effective.
FunIN.13	INHIBIT	Position Directive Prohibition	Effective - enable zero-bit fixed function; Invalid-No zero-bit fixing function.	Originally for pulse prohibition function. Now upgrade to position instruction prohibition, including internal and external position instructions. The logical selection of the corresponding terminal must be set to: level valid.
FunIN.14	P-OT	Forward Overpass Switch	Effective - No positive drive; Invalid - Allows forward drive.	When the mechanical motion exceeds the movable range, enter the overrun prevention function: the logic selection of the corresponding terminal, it is recommended to set to: level effective.
FunIN.15	N-OT	Reverse Overpass Switch	When the mechanical movement exceeds the movable range, enter the over-range prevention function: Effective - No reverse drive; Invalid - allows reverse drive.	The logic selection of the corresponding terminal is recommended to be set to: level effective.
FunIN.16	P-CL	Positive external torque limit	According to the choice of P07-07, the torque limit source is switched. P07-07=1: Effective - Positive external torque limit is effective; Invalid - positive internal torque limit valid. P07-07=3 and AI the limit value is greater than the positive external limit value: Effective - Positive external torque limit is effective;	The logic selection of the corresponding terminal is recommended to be set to: level effective.

Code	Name	Function	Description	Notes
			Invalid - AI torque limit valid. P07-07=4: Effective - AI torque limit effective; Invalid - positive internal torque limit valid.	
FunIN.17	N-CL	Negative External Torque Limit	According to the choice of P07-07, the torque limit source is switched. P07-07=1: Effective-reversal external torque limit effective; Invalid-reversal internal torque limit valid. P07-07=3 and AI the limit value is less than the reverse external limit value: Effective - Reverse external torque limit valid. Invalid - AI torque limit valid. At P07-07=4: Effective - AI torque limit effective; Invalid-reversal internal torque limit valid.	The logic selection of the corresponding terminal is recommended to be set to: level effective.
FunIN.18	JOGCMD+	Forward Point Movement	Valid - enter according to a given instruction; Invalid - Run instruction stop input.	The logic selection of the corresponding terminal is recommended to be set to: level effective.
FunIN.19	JOGCMD-	Negative orientation point	Valid - reverse input according to a given instruction; Invalid - Run instruction stop input.	The logic selection of the corresponding terminal is recommended to be set to: level effective.
FunIN.20	POSSTEP	Step enable	Effective-executes the instruction step quantity instruction; Invalid - the instruction is zero and is located.	The logic selection of the corresponding terminal is recommended to be set to: level effective.
FunIN.21	HX1	Handwheel power signal1	HX1 valid, HX2 invalid: X10 HX1 invalid, HX2 valid: X100 Additional: X1	The logic selection of the corresponding terminal is recommended to be set to: level effective.
FunIN.22	HX2	Handwheel power signal2		
FunIN.23	HX_EN	Handwheel enable signal	Invalid - Position control according to P05-00 function code selection; Effective-receive handwheel pulse signal in position mode for position control.	The logic selection of the corresponding terminal is recommended to be set to: level effective.
FunIN.24	GEAR_SEL	Electronic gear selection	Invalid - electronic gear ratio 1; Effective - electronic gear ratio 2.	The logic selection of the corresponding terminal is recommended to be set to: level effective.
FunIN.25	TOQDirSel	Torque Instruction Direction Setting	Invalid - positive direction; Valid - in the opposite direction.	The logic selection of the corresponding terminal is recommended to be set to: level effective.
FunIN.26	SPDDirSel	Speed Instruction Direction Setting	Invalid - positive direction; Valid - in the opposite direction.	The logic selection of the corresponding terminal is recommended to be set to: level effective.
FunIN.27	POSDirSel	Position Instruction Direction Setting	Invalid - positive direction; valid - in the opposite direction.	The logic selection of the corresponding terminal is recommended to be set to: level effective.

Code	Name	Function	Description	Notes
FunIN.28	PosInSen	Multi-segment position instruction enables	Effective Invalid - ignores internal multi-segment instructions; valid - start internal multiple segments.	The logic selection of the corresponding terminal is recommended to be set to: level effective.
FunIN.29	XintFree	Discontinuation of interrupt duration	Invalidity - prohibition; Effective - enabling.	The logic selection of the corresponding terminal is recommended to be set to: edge valid.
FunIN.31	HomeSwitch	Origin switch	Invalid - not triggered; Effective - trigger.	The logic selection of the corresponding terminal is recommended to be set to: edge valid. The DI function is recommended to be configured to DI8 or DI9 terminals.
FunIN.32	HomingStart	Origin Recovery Enable	Invalidity - prohibition; Effective - enabling.	The logic selection of the corresponding terminal is recommended to be set to: edge valid.
FunIN.33	XintInhibit	Interrupt length prohibition	Effective - prohibition of interruption; Invalid - Allow interrupt fixed length.	The logical selection of the corresponding terminal must be set to: level valid. If set to 2(rising edge valid) drive internal will be forced to change to 1(high level effective); If set to 3(descend edge valid), drive internal force is changed to 0(low level valid); if set to 4(rise edge, descent edge are valid), drive internal force is changed to 0(low level valid)
FunIN.34	Emergency Stop	emergency shut down	Effective-zero speed after shutdown position lock; Invalid-when running state has no effect.	The logic selection of the corresponding terminal is recommended to be set to: level effective.
FunIN.35	ClrPosErr	Clear position deviation	Effective-zero position deviation; Invalid-position deviation is not clear.	The logic selection of the corresponding terminal is recommended to be set to: edge valid. The DI function is recommended to be configured to DI8 or DI9 terminals.
FunIN.36	V_LmtSel	Internal speed limit source	valid - P07-19 as internal positive and negative velocity limits (P07-17=2); Invalid - P07-20 as internal positive and negative speed limit (P07-17=2).	The logic selection of the corresponding terminal is recommended to be set to: level effective.
FunIN.37	PulseInhibit	Pulse instruction forbidden	During position control mode, when the position instruction source is pulse instruction (P05-00=0); Invalid - responsible impulse instruction; valid - does not respond to impulse instructions.	The logic selection of the corresponding terminal is recommended to be set to: level effective.

Output Signal Function Description

Code	Name	Function	Description	Notes
FunOUT.1	S-RDY	Servo ready	Servo ready to receive S-ON valid signal: Effective - Servo ready; Invalid - Servo not ready.	-
FunOUT.2	TGON	Motor rotary output	If the speed of the servo motor is higher than the speed threshold: Effective - motor rotation signal is effective; Invalid - motor rotation signal invalid.	-
FunOUT.3	ZERO	Zero-speed	Output signal when servo motor stops turning: The effective motor speed is zero; Invalid motor speed is not zero.	-
FunOUT.4	V-CMP	Speed consistency	During speed control, the absolute value of the difference between speed and speed instruction of servo motor is less than that of P06-17 speed deviation setting value.	-
FunOUT.5	COIN	Location completed	During position control, the position deviation pulse is effective when it reaches the P05-21 range of positioning completion.	-
FunOUT.6	NEAR	Location close	During position control, the position deviation pulse is effective when it reaches the positioning signal amplitude P05-22 set value.	-
FunOUT.7	C-LT	Torque limitation	Torque limit confirmation signal: Effective - motor torque limitation; Invalid - Motor torque is not limited.	-
FunOUT.8	V-LT	Speed limit	Confirmation signal of speed limitation in torque control: Effective - motor speed limit; Invalid-motor speed is not limited.	-
FunOUT.9	BK	Lock output	Lock signal output: Effective - close, release lock; Invalid - start lock.	-
FunOUT.10	WARN	Warning output	Warning output signal is valid. (conduction)	-
FunOUT.11	ALM	Fault output	The state is valid when the fault is detected.	-
FunOUT.12	ALMO1	Output 3 alarm codes	Output 3 bit alarm code.	-
FunOUT.13	ALMO2	Output 3 alarm codes	Output 3 bit alarm code.	-
FunOUT.14	ALMO3	Output 3 alarm codes	Output 3 bit alarm code.	-
FunOUT.15	Xintcoin	Interrupt length completed	Effective - interrupt fixed length positioning completed; Invalid - interrupt fixed length positioning is not complete.	-

Code	Name	Function	Description	Notes
FunOUT.16	HomeAttain	Origin zero output	Zero state of origin: Effective - zero origin; Invalid - the origin does not return to zero.	-
FunOUT.17	ElecHome Attain	Electrical zero output	Electrical return status: Effective - electrical origin back to zero; Invalid - the electrical origin does not return to zero.	-
FunOUT.18	ToqReach	Torque reaches output	Effective - the absolute value of torque reaches the set value; Invalid - the absolute value of torque is less than the set value.	-
FunOUT.19	V-Arr	Speedto output	Effective-speed feedback to the set value; Invalid-speed feedback does not reach the set value.	-
FunOUT.20	AngIntRdy	Angle Identification Output	Effective - complete angle identification; Invalid - Incomplete angle identification.	-
FunOUT.21	DB	DB Brake output	Effective - dynamic brake relay disconnected; Invalid-dynamic brake relay suction.	
FunOUT.22	CmdOk	Internal instruction output	Effective - Internal instruction completed; Invalid - Internal instruction not completed.	

Chapter 7 Trouble shooting

7.1 Fault and warning handling at startup

7.1.1 Position control mode

➤ Fault inspection

Boot process	Failure phenomenon	Reason	Confirmation method
Turn on the control power (L1C L2C) Main power supply (L1 L2) (L1 L2 L3)	The digital tube does not light up or does not display "rdy"	1. Control power supply voltage failure	<ul style="list-style-type: none"> ◆ After unplugging CN1, CN2, CN3, CN4, the fault still exists ◆ Measure the AC voltage between (L1C, L2C).
		2. Main power supply voltage failure	<ul style="list-style-type: none"> ◆ Single-phase 220V power supply models measure the AC voltage between (L1, L2). The main power supply DC bus voltage amplitude (voltage between B1/Φ, 1) is lower than 200V, and the digital tube displays "nrd". ◆ Three-phase 220V/380V power supply models measure the AC voltage between (L1, L2, L3). The main power supply DC bus voltage amplitude (voltage between B1/Φ and 1) is lower than 460V and the digital tube displays "nrd".
		2. The program terminal is shorted	◆ Check the terminal of the programming program to confirm whether it is short-circuited.
		4. Servo drive failure	◆ -
	Display "FU.xxx"	Refer to Chapter 7.2 to find the cause and eliminate the fault.	
	■ After troubleshooting the above fault, the panel should display "rdy".		
Servo enable signal is valid (S-ON is ON)	Display "FU.xxx"	Refer to Chapter 7.2 to find the cause and eliminate the fault.	
	Servo motor shaft is in free	1. The servo enable signal is invalid	◆ Switch the panel to the servo status display, and check whether the panel displays "rdy" instead of "run".

	running state		<ul style="list-style-type: none"> ◆ Check P03 and P17 groups, whether to set the servo enable signal (DI function 1: S-ON). If it has been set, check whether the corresponding terminal logic is valid; if not, set it and make the terminal logic valid. Refer to Chapter 6 "P03 Group: Terminal Input Parameters" setting method. ◆ If the P03 group has set the servo enable signal and the corresponding terminal logic is valid, but the panel still displays "rdy", then check whether the DI terminal wiring is correct. Refer to Chapter 5.
	2. Wrong control mode selection		<ul style="list-style-type: none"> ◆ Check whether P02-00 is 1. If it is set to 2 by mistake (torque mode), the motor shaft is also in free running state because the default torque command is zero.
	<ul style="list-style-type: none"> ■ After troubleshooting the above fault, the panel should display "run". 		
Input position command	Servo motor does not rotate	Input position command counter (P0B-13) is 0	<ul style="list-style-type: none"> ◆ High/low speed pulse port wiring error When P05-00=0 pulse command source, check whether the high/low speed pulse port wiring is correct, please refer to Chapter 5 "Wiring", and check whether the setting of P05-01 matches. ◆ Position command not entered <ol style="list-style-type: none"> 1. Whether to use DI function 13 (FunIN.13: Inhibit, position command prohibition) or DI function 37 (FunIN.37: PulseInhibit, pulse command prohibition) 2. When P05-00=0 pulse command source, the host computer or other pulse output device does not output pulses. Use an oscilloscope to check whether there is pulse input at the high/low speed pulse port. Please refer to Chapter 5 "Wiring"; 3. When P05-00=1 step command source, check whether P05-05 is 0, if it is not 0, check whether DI function 20 (FunIN.20: PosStep, step command enable) and corresponding Whether the terminal logic is valid; 4. When P05-00=2 multi-segment position command source, check whether the P11 group parameters are set correctly, if correct, check whether DI function 28 (FunIN.28: PosInSen, internal multi-segment position enable) and the corresponding terminal logic are valid. ; 5. If you have used the interrupt fixed-length function, check whether P05-29 is 1, (after the interrupted fixed-length operation is completed, can you directly respond to other position commands), if it is 1, confirm whether to use DI function 29 (FunIN.29: XintFree, interrupt fixed-length state release) release the locked state.
	Servo motor reverse	Input position command counter (P0B-13) is negative	<ul style="list-style-type: none"> ◆ When P05-00=0 is the source of pulse command, check whether the parameter setting of P05-15 (pulse command form) corresponds to the actual input pulse. If it is inconsistent, the setting of P05-15 is wrong or the terminal wiring is wrong; ◆ P05-00=1 when the step command source, check the positive and negative values of P05-05; ◆ P05-00=2 When the multi-segment position command source check the positive and negative of each segment of the P11 group; ◆ Check whether DI function 27 (FunIN.27: PosDirSel, position command direction setting) has been set and whether the corresponding terminal logic is valid; Check whether the P02-02 parameter is set incorrectly.
	<ul style="list-style-type: none"> ■ After troubleshooting the above fault, the motor can rotate. 		
Unstable rotation at low speed	Unstable speed when rotating at low speed	Unreasonable gain setting	<ul style="list-style-type: none"> ◆ Automatic gain adjustment.
	Motor shaft vibration left and right	Load moment of inertia ratio(P08-15) too large	<ul style="list-style-type: none"> ◆ If it can be operated safely, perform inertia identification again; ◆ Automatic gain adjustment

	■ After troubleshooting, the servo motor can rotate normally.		
normal operation	No location	Creating non-compliant locations Deviation	◆ Determine the input position instruction counter (P0B-13), feedback pulse counter (P0B-17) and mechanical stop position. the confirmation steps are as follows.

➤ Fault Cause Checking Steps for Untimely Positioning

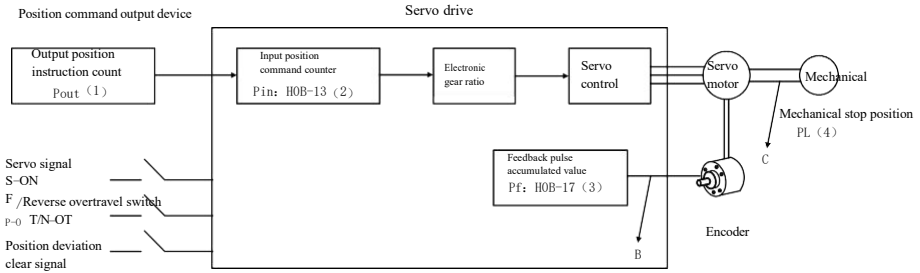

Figure 7-1 Block diagram of positioning control principle

Check the 4 signals above when the location is not correct:

- 1) Count value Pout; of output position instruction in position instruction output device;
- 2) The input position instruction counter received by the servo controller Pin, corresponds to the parameter P0B-13;
- 3) The cumulative value of feedback pulse of servo motor with encoder Pf, corresponding to parameter P0B-17;
- 4) PL of mechanical stops.

3 reasons for incorrect positioning, corresponding to the A、B、C, in the graph:

A means that the input bit is caused by noise in the connection between the output device of the 1:1 position instruction (especially the upper computer) and the servo driver

Set instruction count error;

During the operation of the motor, the input position instruction is interrupted.

Reason: servo enable signal is invalid (S-ON OFF), forward / reverse overrun switch signal (P-OT or N-OT)

has

Effect, position deviation clearance signal (ClrPosErr) is effective;

B representation: encoder feedback position signal error (signal interference).

C representation: mechanical position sliding occurs between machinery and servo motor. In an ideal state where there is no positional deviation, the following relationship holds:

- $P_{out} = P_{in}$, Output position instruction count value = input position instruction counter
- $P_{in} \times \text{Electronic gear ratio} = P_f$, Input position instruction counter \times Electronic gear ratio = Feedback pulse accumulation
- $P_f \times \Delta L = PL$, Feedback pulse accumulation \times 1 position instruction corresponds to load displacement = Position of mechanical stop

In the event of inaccurate positioning, check method:

a) $P_{out} \neq P_{in}$

Failure cause : A

Exclusion Methods and Steps:

- ① Check pulse input terminals (For low- or high-speed pulse input terminals, refer to Chapter 5, "Wiring") Whether use double stranded shield;

- ② If the open circuit input mode of collector in low speed pulse input terminal is selected, it should be changed to differential input mode;
- ③ Connection of pulse input terminals must be separated from the main circuit (L1C、L2C、L1L2L3、U、V、W) line;
- ④ A low-speed pulse input terminal is selected to increase the filter time constant (P0A-24);
Conversely, the high-speed pulse input terminal is selected to increase the filter time constant of the high-speed pulse input pin (P0A-30).

b) $P_{in} \times \text{Electronic gear ratio} \neq P_f$

Failure cause : B

Exclusion Methods and Steps:

- ① Check to see if there is a operation, resulting in the instruction not being fully executed and the servo has stopped;
- ② When the position deviation clearance signal (ClrPosErr) is valid, check whether the position deviation clearance mode (P05-16) is reasonable.

c) $P_f \times \Delta L \neq PL$

failure cause : C

Exclusion Methods and Steps: Check the mechanical connection step by step to find the position where the relative sliding occurs.

7.1.2 Speed Control Mode

start-up procedure	Error	Reason	Confirmation way
Switch on control power (L1C L2C) Main power source (L1 L2) (L1 L2 L3)	Digital tube not on or on"rdy"	1. Control power supply voltage failures	<ul style="list-style-type: none"> ◆ After pulling out the CN1、CN2、CN3、CN4, the fault still exists . ◆ Measure AC voltage between (L1C、L2C).
		2. Main supply voltage fault Main supply voltage fault	<ul style="list-style-type: none"> ◆ Single phase 220 V power supply model measurement (L1、L2) between the AC voltage. Main power DC bus voltage amplitude (B1/Φ, 1 voltage) less than 200 V digital tube display nrd" ◆ Three-phase 220 V/380V power supply model measurement (L1L2L3) between the AC voltage. Main power supply DC bus voltage amplitude (B1/Φ, 1 voltage) less than 460 V digital tube display nrd".
		3. Short connection of burn program terminals	◆ Check the terminal of the burning program to confirm that it is short connected.
		4. Servo Driver Failure	-
	Panel display "FU.xxx"	Refer to Section 7.2 to find causes and troubleshoot	
		■ After troubleshooting, the panel should display rdy"	
Servo enable signal set to be effective (S-ON is ON)	Panel display "FU.xxx"	Refer to Section 7.2 to find causes and troubleshoot	
	Shaft of servo motorIn free state	1. Servo enable signal invalid	<ul style="list-style-type: none"> ◆ Switch the panel to the servo state display to see if the panel is displayed as "Rdy ", instead of "run". ◆ View P03 and P17 groups to set servo enable signals (DI function 1: S-ON). If set, see if the corresponding terminal logic is valid; if not, set and make the terminal logic valid. Can refer to Chapter 6" Group P03: Terminal Input Parameters "setting method . ◆ When the P03 group has set the servo enable signal and the corresponding terminal logic is valid, but the panel still displays "rdy", check that the DI terminal wiring is correct, refer to Chapter 5.
		2. Control mode selection error	◆ Check to see if the P02-00 is 0, and if it is set to 2(torque mode), the motor shaft is also in free operation because the default torque instruction is zero.
		■ After troubleshooting, the panel should show"run".	
Input speed	The servo	speed instruction	◆ AI wiring error

instruction	motor does not rotate or rotate incorrectly	(P0B-01)0	<p>When selecting analog input instructions, first check whether the AI analog input channel is selected correctly, and then check whether the AI terminal wiring is correct please refer to Chapter 5.</p> <p>Speed instruction selection error</p> <p>Check if the P06-02 is set correctly</p> <ul style="list-style-type: none"> ◆ No speed instruction input or speed instruction exception <ol style="list-style-type: none"> 1. select analog input instruction, first check whether the relevant parameters AI P03 group are set correctly; then check whether the input voltage signal of external signal source is correct, can be observed by oscilloscope or read by P0B-21 or P0B-22; 2. the numbers to see if the P06-03 is correct; 3. multi-segment speed instruction to timing to see if P12 set parameters are correct; 4. communication timing to see if the P31-09 is correct; 5. the timing of the point speed instruction to see if the P06-04 is correct DI functions 18 and 19 have been set, and whether the corresponding terminal logic is valid; 6. see if the acceleration and deceleration time P06-05 and P06-06 settings are correct; 7. whether the zero-bit fixed function is incorrectly enabled, that is, to view the DI function; Whether the 8. is misconfigured and whether DI valid logic of the corresponding terminal is correct.
Input speed instruction	Servo motor reversal	Velocity instruction (P0B-01) is negative	<ul style="list-style-type: none"> ◆ When selecting analog input instruction, check whether the positive and negative polarity of input signal is reverse; ◆ Digital timing to see if the P06-03 is less than 0; ◆ A multi-segment speed instruction is given timing to view the positive and negative of each group of speed instructions in P12 group; ◆ Communication timing to see if the P31-09 is less than 0; ◆ Point speed instruction gives timing to see if the P06-04 value, DI function 18,19 valid logic and expected steering match; ◆ See if the DI function 26(FunIN.26: SpdDirSel, speed instruction direction setting) and the corresponding terminal logic are valid; ◆ Check to see if the P02-02 parameter is set incorrectly.
	<p>■ After troubleshooting, the servo motor can rotate</p>		
Low speed rotation	Unstable speed at low speed rotation	Unreasonable gain setting	<ul style="list-style-type: none"> ◆ Automatic gain adjustment.
	Motor shaft left and right vibration	Load moment of inertia ratio (P08-15) Too big	<ul style="list-style-type: none"> ◆ If it can operate safely, the inertia identification is carried out again; ◆ Automatic gain adjustment.

7.1.3 Torque Control Mode

Start-up procedure	Fault phenomenon	Reason	Confirmation method
Switch oncontrol power (L1C L2C) Main Power (L1 L2) (L1 L2 L3)	The digital tube is not on“rdy”	1、 Control power supply voltage failures	<ul style="list-style-type: none"> ◆ After pulling out the CN1、 CN2、 CN3、 CN4, the fault still exists . ◆ AC voltage between measurements (L1C、 L2C);
		2、 Control power supply voltage failures	<ul style="list-style-type: none"> ◆ Single phase 220 V power supply model measurement (L1 、 L2) between the AC voltage. Main power DC bus voltage amplitude (B1/Φ,1 voltage) less than 200 V digital tube display nrd”. ◆ Three-phase 220 V/380V power supply model measurement (L1L2L3) between the AC voltage. Main power supply DC bus voltage amplitude (B1/Φ,1 voltage) less than 460 V digital tube display nrd”.
		3、 Short connection of burn program terminals	◆ Check the terminal of the burning program to confirm that it is short connected.
		4、 Servo Driver Failure	-
	panel display “FU.xxx”	Refer to Section 6.2 to find out the cause and troubleshoot.	

<p>■ After troubleshooting the above, the panel rdy".</p>			
Servo enable signal set to be effective (S-ON set ON)	Panel display "FU.xxx"	Refer to Section 6.2 to find out the cause and troubleshoot.	
	The axis of the servo motor is in free running state	Servo enable signal invalid	<ul style="list-style-type: none"> ◆ Switch the panel to the servo state display to see if the panel is displayed as Rdy ", instead of run". ◆ View P03 and P17 groups to set servo enable signals (DI function 1: S-ON). If set, see if the corresponding terminal logic is valid; if not, set and make the terminal logic valid. Refer to Chapter 6, P03 Group: terminal input parameters setting method. ◆ When the P03 group has set the servo enable signal and the corresponding terminal logic is valid, but the panel still displays "rdy", check that the DI terminal wiring is correct, refer to Chapter 5.
	<p>■ After troubleshooting, the panel should display run".</p>		
Input torque instruction	Servo motor not rotating	Internal torque instruction (P0B-02)	<p>AI wiring error For analog input instructions, see if the AI terminal wiring is correct, please refer to Chapter 4.</p> <p>Error in selecting torque instruction Check that the P07-02 is set correctly.</p> <p>No torque instruction entered When 1. select analog input instruction, first check whether the relevant parameters AI P03 group are set correctly; then check whether the input voltage signal of external signal source is correct, can be observed by oscilloscope or read by P0B-21 or P0B-22; 2. the number to time to see if the P07-03 is 0; 3. communication to timing to see if the P31-11 is 0.</p>
Input torque instruction	Servo motor reversal	Internal torque instruction (P0B-02) is negative	<ul style="list-style-type: none"> ◆ When the analog input instruction is selected, whether the input voltage polarity of the external signal source is reverse can be viewed by oscilloscope or through P0B-21 or P0B-22; ◆ Digital timing to see if the P07-03 is less than 0; ◆ Communication timing to see if the P31-11 is less than 0; ◆ See if the DI function 25(FunIN.25 : ToqDirSel, torque instruction direction setting) and the corresponding terminal logic are valid; ◆ Check to see if the P02-02 parameter is set incorrectly.
			<p>■ After removing the above fault, the servo motor can rotate.</p>
Low speed rotation	Unstable speed at low speed rotation	Unreasonable gain setting	◆ Automatic gain adjustment.
	Motor shaft left and right vibration	Load moment of inertia ratio (P08-15) Too big	◆ If it can run safely, the inertia identification is carried out again, and the automatic gain adjustment is carried out.

7.2 Runtime failures and warning handling

7.2.1 Fault and Warning Code Table

Fault and warning classification

Servo drive failures and warnings are classified by severity into three categories ,1,2,3, severity :1>2>3, as follows:

- Category 1(NO.1) Non-resetable faults;
- Class 1(NO.1) Resetable faults;
- Class 2(NO.2) Resetable faults;
- Class 3(NO.3) Resetable warning.

"Resetable" means to stop the panel failure display by giving a reset signal.

Specific operation: set parameter P0D-01=1(fault reset) or use DI function 2(FunIN.2 : ALM-RST, fault and

warning reset) and set to logic valid, can make panel stop fault display.

NO.1、NO.2 reset method of resettable fault: turn off servo enable signal (S-ON set to OFF), then set P0D-01=1 or use DI function 2.

NO.3 reset method of resettable warning: set P0D-01=1 or use DI function

3. Notes: ■ for some faults or warnings, you must change the settings to remove the cause before reset, but reset does not mean that the change takes effect. For changes that need to be re-controlled (L1C、L2C) to take effect, the control power must be re-controlled; for changes that require downtime to take effect, the servo enable must be turned off. After the change takes effect, the servo drive can run normally.

☆ Association function code:

Function code	Name	Setting range	Unit	Factory setting	Setting	Effective time	Relevant models
P0D 01	Fault reset	0: no operation 1: failure and warning reset	-	0	Stop setting	take effect	-

☆ Associated function number:

Function code	Name	Function name	Function
FunIN.2	ALM-RST	Failure and warning reset signal	<ul style="list-style-type: none"> ◆ The DI function is edge effective, the level continues to be high / low usually invalid. ◆ According to the alarm type, some alarm reset servo can continue to work. ◆ When assigned to low speed DI, if the DI logic is set to level effective, it will be forced to be effective along the change, and the effective level change must be kept above 3 ms, otherwise the fault reset function will be invalid. Do not assign fault reset function to fast DI, otherwise function is invalid. Invalid, no reset fault and warning; valid, reset fault and warning.

1) Failure and warning records

The servo driver has the function of fault recording, which can record the last 10 faults and warning names and the state parameters of the servo driver when the fault or warning occurs. If repeated failures or warnings occur in the last 5 times, the fault or warning code, that is, the drive status, is recorded only once.

After the fault or warning reset, the fault record will still save the fault and warning; use the system parameter initialization function (P02-31=1 or 2) to clear the fault and warning record.

Through monitoring parameters P0B-33 you can select the number of failures or warnings from the current fault n,P0B-34 you can view the n 1 fault or warning name, P0B-35~P0B-42 you can view the status parameters of the servo driver when the first fault or warning occurs. FU.000". P0B-34 on panel when failure occurs

When viewing the P0B-34(n 1 fault or warning name) through the panel, the panel displays "FU.xxx","xxx" as fault or warning code; when reading through driving debugging platform software or communication, it reads decimal data of the code. It needs to be converted into hexadecimal data to reflect real fault or warning code, such as

Panel displays failures or warnings“FU.xxx”	P0B-34 (decimal system)	P0B-34 (hexadecimal)	Illustration
FU.101	257	0101	0: Class 1 Non-resettable Fault 101: Fault Code
FU.130	8496	2130	2: Class 1 Resettable Fault 130: Fault Code
FU.121	24865	6121	6: Class 2 Resettable Fault 121: Fault Code
FU.110	57616	E110	E: Class 3 Resettable Warning 110: Warning Code

2) Fault and Warning Code Output

Servo drives can output the current highest level of fault or warning codes.

- a) "Fault coded output" means setting 3 DO terminals of the servo drive to DO functions 12,13,14, FunOUT.12 of which
- b) ALMO1(alarm code bit 1, abbreviated as AL1), FunOUT.13:
- c) ALMO2(alarm code bit 2, abbreviated as AL2), FunOUT.14:
- d) ALMO3(alarm code 3, abbreviated as AL3).
- e) Different faults occur, the level of 3 DO terminals will change.

Category 1(NO.1) Non-reset faults:

Display	Fault name	Fault type	Resets	Coding output		
				AL3	AL2	AL1
FU.101	P02 and above group parameters are abnormal	NO.1	No	1	1	1
FU.102	Programmable logic configuration failure	NO.1	No	1	1	1
FU.104	Programmable logic interrupt fault	NO.1	No	1	1	1
FU.105	Internal program exception	NO.1	No	1	1	1
FU.108	Parameter storage failure	NO.1	No	1	1	1
FU.111	Internal fault	NO.1	No	1	1	1
FU.120	Product matching failure	NO.1	No	1	1	1
FU.122	Absolute position mode product matching failure	NO.1	No	1	1	1
FU.136	Data check error in motor ROM or parameter not saved	NO.1	No	1	1	1
FU.201	Over current 2	NO.1	No	1	1	0
FU.208	FPGA system sampling operation timeout	NO.1	No	1	1	0
FU.210	Output short circuit to ground	NO.1	No	1	1	0
FU.220	Phase sequence error	NO.1	No	1	1	0
FU.234	Speed car	NO.1	No	1	1	0
FU.740	Encoder interference	NO.1	No	1	1	1
FU.A33	Encoder data is abnormal	NO.1	No	0	1	0

Note : "1" means valid , "0" means invalid, does not represent the level of the DO terminal.

f) Class 1 (NO.1) Resettable faults:

Display	Fault name	Fault type	Resets	Encoding output		
				AL3	AL2	AL1
FU.130	DI function repeated allocation	NO.1	Yes	1	1	1
FU.131	DO function allocation exceeds limit	NO.1	Yes	1	1	1
FU.207	D/Q axis current overflow fault	NO.1	Yes	1	1	0
FU.400	Main circuit over voltage	NO.1	Yes	0	1	1
FU.410	Main circuit under voltage	NO.1	Yes	1	1	0
FU.602	Angle recognition failed	NO.1	Yes	0	0	0

g) Class 2 (NO.2) Resettable faults:

Display	Fault name	Fault type	Resets	Encoding output		
				AL3	AL2	AL1
FU.121	Servo ON command invalid fault	NO.2	Yes	1	1	1
FU.420	Main circuit lack of phase	NO.2	Yes	0	1	1
FU.430	Control voltage under voltage	NO.2	Yes	0	1	1
FU.500	Over speed	NO.2	Yes	0	1	0
FU.510	Pulse output over speed	NO.2	Yes	0	1	0

FU.610	Drive overload	NO.2	Yes	0	0	0
FU.620	Motor over load	NO.2	Yes	0	0	0
FU.625	Brake closed abnormally	NO.2	Yes	0	0	0
FU.626	Brake opened abnormally	NO.2	Yes	0	0	0
FU.630	Motor blocked	NO.2	Yes	0	0	0
FU.650	Radiator overheated	NO.2	Yes	0	0	0
FU.731	Encoder battery failure	NO.2	Yes	1	1	1
FU.733	Encoder multi-turn counting error	NO.2	Yes	1	1	1
FU.735	Encoder multi-turn counting over flow	NO.2	Yes	1	1	1
FU.834	AD sampling overvoltage	NO.2	No	1	1	1
FU.835	High-precision AD sampling failure	NO.2	No	1	1	1
FU.B00	Position deviation is too large	NO.2	Yes	1	0	0
FU.B01	Pulse input abnormal	NO.2	Yes	1	0	0
FU.B02	Full closed loop position deviation is too large	NO.2	Yes	1	0	0
FU.B03	Electronic gear ratio setting exceeds limit	NO.2	Yes	1	0	0
FU.B04	Full closed loop function parameter setting error	NO.2	Yes	1	0	0
FU.D03	CAN communication connection interrupted	NO.2	Yes	1	0	1

h) Warning reset:

Display	Warning name	Fault type	Resets	Encoding output		
				AL3	AL2	AL1
FU.110	Frequency division pulse output setting failure	NO.3	Yes	1	1	1
FU.601	Back to origin timeout failure	NO.3	Yes	0	0	0
FU.730	Encoder battery warning	NO.3	Yes	1	1	1
FU.831	AI zero drift is too large	NO.3	Yes	1	1	1
FU.900	DI emergency brake	NO.3	Yes	1	1	1
FU.909	Motor overload warning	NO.3	Yes	1	1	0
FU.920	Braking resistor overload	NO.3	Yes	1	0	1
FU.922	External braking resistor is too small	NO.3	Yes	1	0	1
FU.939	Motor power line is broken	NO.3	Yes	1	0	0
FU.941	Change parameters need to be re-powered to take effect	NO.3	Yes	0	1	1
FU.942	Frequent parameter storage	NO.3	Yes	0	1	1
FU.950	Forward over travel warning	NO.3	Yes	0	0	0
FU.952	Reverse over travel warning	NO.3	Yes	0	0	0
FU.980	Encoder internal fault	NO.3	Yes	0	0	1
FU.990	Input phase loss warning	NO.3	Yes	0	0	1
FU.994	CAN address conflict	NO.3	Yes	0	0	1
FU.A40	Internal fault	NO.3	Yes	0	1	0

7.2.2 Trouble shooting method

FU.101: Abnormal servo internal parameters

1) Production mechanism:

The total number of function codes has changed, which usually appears after updating the software;

The function code parameter values of P02 group and later groups exceed the upper and lower limits, which usually appear after updating the software.

Reason	Confirmation method	Treatment measures
I. Control power supply voltage drops instantaneously	◆ Confirm whether it is in the process of cutting off the control power (L1C, L2C) or a momentary power failure	After the system parameters are restored and initialized (P02-31=1), then rewrite the parameters.

	occurs.	
	<ul style="list-style-type: none"> ◆ Measure whether the input voltage on the non-drive side of the control cable meets the following specifications during operation: ◆ 220V drive: ◆ Effective value: 220V-240V ◆ Allowable deviation: -10% ~ +10% (198V~264V) ◆ 380V driver: ◆ Effective value: 380V-440V ◆ Allowable deviation: -10% ~ +10% (342V~484V) 	Increase the power supply capacity or replace a large-capacity power supply. After the system parameters are restored and initialized (P02-31=1), rewrite the parameters.
2. Instantaneous power failure during parameter storage	◆ Confirm whether an instantaneous power failure occurs during parameter value storage.	Re-power on and re-write the parameters after the system parameters are restored and initialized (P02-31=1).
3. The number of writes of the parameter within a certain period of time exceeds the maximum	◆ Check whether the upper device frequently changes parameters.	Change the parameter writing method and rewrite. Or the servo drive is faulty, replace the servo drive.
4. Updated software	◆ Confirm whether the software has been updated.	Reset the drive model and motor model, and the system parameters are restored and initialized (P02-31=1)
5. Servo drive failure	◆ After turning on the power supply several times and restoring the factory parameters, if the fault is still reported, the servo drive has a fault.	Replace the servo drive

2) FU.102: Programmable logic configuration failure

Production mechanism:

- FPGA and MCU software versions do not match;
- The FPGA or MCU related hardware is damaged, causing the MCU and FPGA to fail to establish communication

Reason	Confirmation method	Treatment measures
1.FPGA and MCU software version is not Match	◆ Check the MCU software version number P01-00 and FPGA software version number P01-01 through the panel or drive debugging platform, etc., and confirm whether the highest non-zero values of the two software version numbers are consistent.	Consult our technical support to update the FPGA or MCU software that matches each other.
2.FPGA Fault	◆ The fault is still reported after turning on the power several times.	Replace the servo drive

3) FU.104: Programmable logic interrupt fault

In order to distinguish the mechanism of the fault, the servo drive can display different internal fault codes under the same external fault code, which can be checked through P0B-45.

Production mechanism:

- MCU or FPGA access timeout

Reason	Confirmation way	Settlement way
1.FPGA fault(FU.104)	◆ The fault is still reported after turning on the power several times.	Replace the servo drive
2. Handshake between FPGA and MCU is abnormal (FU.100)		
3. Drive internal operation timeout (FU.940)		

4) FU.105: Internal program exception

Production mechanism:

- When EEPROM read/write function codes, the total number of function codes is abnormal.
- The range of the function code setting value is abnormal (usually after updating the program)

Reason	Confirmation way	Settlement way
1. EEPROM error	◆ Confirm according to the method of FU.101.	After the system parameters are restored and initialized (P02-31=1), power on again
2. Servo drive error	◆ The fault is still reported after turning on the power several times.	Replace the servo drive

5) FU.108: Parameter storage failure

Production mechanism:

- Parameter value cannot be written to EEPROM; parameter value cannot be read from EEPROM.

Reason	Confirmation way	Settlement way
1. Parameter writing is abnormal	◆ After changing a parameter, power on again to check whether the parameter value is saved.	It is not saved, and the fault still occurs after multiple power-on. The drive needs to be replaced.
2. Parameter reading is abnormal		

6) FU.120: Product matching failure

Production mechanism:

- The motor and driver do not match or the parameter setting is wrong.

Reason	Confirmation way	Settlement way
1. Product number (motor or drive) does not exist	Internal fault code P0B45=0120 or 1120 ◆ Check whether the motor nameplate is matched by our company. According to the motor nameplate, confirm whether the setting of P00-00 is correct.	Reset P00-00 (motor number) according to the motor nameplate or replace with a matching motor.
	Internal fault code P0B45=2120 ◆ Check the drive model (P01-02) to see if there is this drive model.	The drive number does not exist. Set the correct drive model according to the drive nameplate.
2. The power level of the motor and the drive do not match	Internal fault code P0B45=3120 ◆ Check the drive model (P01-02) whether it matches with the bus motor model (P00-05).	Replace the product that does not match

7) FU.121: Servo ON command invalid fault

Production mechanism:

- When using some auxiliary functions, a redundant servo enable signal is given

Reason	Confirmation way	Settlement way
1. When internally enabled, external Servo enable signal (S-ON) is valid	◆ Confirm whether to use auxiliary functions: P0D-02, P0D-03, P0D-12, and DI function 1 (FunIN.1: S-ON, servo enable signal) is valid.	Set DI function 1 (including hardware DI and virtual DI) signals to be invalid.

8) FU.122: Absolute position mode product matching failure

Production mechanism:

- Absolute position mode motor does not match or the motor number is set incorrectly

Reason	Confirmation way	Settlement way
In the absolute position mode, the detected motor does not match or the motor number is set incorrectly	◆ Check whether the motor nameplate is a multi-turn absolute encoder motor. ◆ Check whether P00-00 (motor number) is correct.	Reset P00-00 (motor number) according to the motor nameplate or replace with a matching motor.

9) FU.130: DI Duplicate function assignment

Production mechanism:

- The same DI function is allocated repeatedly, including hardware DI and virtual DI.

- DI the function number exceeds the number of DI functions.

Reason	Confirmation way	Settlement way
1. When DI function is allocated, the same function is repeatedly allocated to multiple DI terminals	◆ Check whether P03-02/P03-04...P03-20, P17-00/P17-02...P17-30 are set with the same non-zero DI function number.	Re-assign the parameters of group P03 and P17 assigned the same non-zero function number to different function numbers, and then power on again to make the changes take effect, or turn off the servo enable signal first and give a "reset signal" "To make the changes take effect.
2. DI function number exceeds the number of DI functions	◆ Has the MCU program been updated?	After the system parameters are restored and initialized (P02-31=1), power on again.

10) FU.131: DO Function allocation exceeds limit

Production mechanism:

- DO The function number exceeds the number of DO functions.

Reason	Confirmation way	Settlement way
1. The function number exceeds the number of DO functions.	◆ Has the MCU program been updated?	After the system parameters are restored and initialized (P02-31=1), power on again.

11) FU.136: The data in the motor encoder ROM is checked incorrectly or parameters are not stored

Production mechanism:

- When the drive reads the parameters of the encoder ROM area, it is found that the parameters are not stored, or the parameters are inconsistent with the agreed values.

Reason	Confirmation way	Settlement way
1. The drive and motor type do not match	◆ According to motor brand and motor model type, ensure P00-00 setting correct ◆ For this series of drives and 17bit servo motors (-U2***), check whether P00-00 (motor number) is 14130.	Replace with a matching drive and motor, and power on again. ■ When using our driver and 17bit servo motor, make sure that P00-00= 14130.
2.The parameter verification error in the ROM of the bus type incremental encoder or the parameter is not stored	◆ Check whether the encoder cable provided by our company is used. The cable has no broken skin or disconnection, and there is no bad contact between the terminals on both sides and reliable connection. ◆ Measure the signals at both ends of the encoder cable: PS+, PS-, +5V, GND, and observe whether the signals on both sides are consistent. Signal definition refers to hardware wiring	Use our standard encoder cable, ensure a tight connection between the terminals at the motor end, tighten the screws at the driver end, and replace with a new encoder cable if necessary. Encoder cables and power cables (L1, L2, L3, U, V, W) must not be bundled, they should be routed separately.
3. Drive failure	◆ The fault is still reported after power-on again.	Replace the servo drive

12)FU.201: over current 2

Production mechanism:

- Overcurrent detected by hardware

Reason	Confirmation way	Settlement way
1. The input command is synchronized with the servo on or the input command is too fast	◆ Check whether the command has been input before the servo panel displays "Rdy".	Command sequence: After the servo panel displays "Rdy", turn on the servo enable signal (S-ON) first, and then input the command. If allowed, add the command filter time constant or increase the acceleration/deceleration time.
4. Braking resistance is too small or short circuited	◆ If using the built-in braking resistor (P02-25=0), confirm whether B2 and B3 are reliably connected by wires. If yes, measure the resistance between B1/⊕	If the built-in braking resistor is used and the resistance value is "0", then adjust to use an external braking resistor (P02-25=1/2), and remove the wire between B2 and B3. The resistance value and power can be selected as

	<p>and B3;</p> <ul style="list-style-type: none"> ◆ If using an external braking resistor (P02-25=1/2), measure the resistance of the external braking resistor between B1/⊕ and B2. ◆ Please refer to Chapter 1 for brake resistor specifications. 	<p>the internal The specifications of the braking resistors are the same; if an external braking resistor is used, the resistance value is less than P02-21, refer to Chapter 1 "Specifications of braking resistors", replace with a new resistor, and reconnect between B1/⊕ and B2. Be sure to set P02-26 (power of external braking resistor) and P02-27 (resistance value of external braking resistor) consistent with the actual parameters of external braking resistor.</p>
3. Poor contact of the motor cable	<ul style="list-style-type: none"> ◆ Check whether the connections between the two ends of the drive power cable and the U V W side of the drive in the motor cable are loose. 	Tighten loose or detached wiring.
4. Ground the motor cable	<ul style="list-style-type: none"> ◆ After ensuring that the drive power cable and motor cable are tightly connected, respectively measure whether the insulation resistance between the UVW end of the drive and the ground wire (PE) is a megaohm (MΩ) value. 	Replace the motor when the insulation is poor.
5. Short circuit of motor U V W cable	<ul style="list-style-type: none"> ◆ Unplug the motor cable and check whether there is a short circuit between the motor cable U V W and whether there are burrs in the wiring. 	Connect the motor cables correctly.
6. Motor burns out	<ul style="list-style-type: none"> ◆ Unplug the motor cable and measure whether the resistance of the motor cable U V W is balanced. 	If unbalanced, replace the motor.
7. Unreasonable gain setting, motor oscillation	<ul style="list-style-type: none"> ◆ Check whether the motor vibrates or has a sharp sound during the startup and operation of the motor. You can also use the drive debugging platform to view the "current feedback". 	Make gain adjustments.
8. Encoder wiring error, aging and corrosion, encoder plug loose	<ul style="list-style-type: none"> ◆ Check whether the standard encoder cable of our company is used, and whether the cable is aging, corroded, or the connector is loose. ◆ Turn off the servo enable signal, turn the motor shaft by hand, and check whether P0B-10 changes with the rotation of the motor shaft. 	Re-solder, plug tightly or replace the encoder cable.
9. Drive failure	<ul style="list-style-type: none"> ◆ Unplug the motor cable and power on again, the fault is still reported. 	Replace the servo drive.

13) FU.207: D/Q Shaft current overflow fault

Production mechanism:

- Abnormal current feedback causes the internal registers of the driver to overflow;
- Abnormal encoder feedback causes the internal registers of the drive to malfunction.

Reason	Confirmation way	Settlement way
1.DQ Shaft current overflow	<ul style="list-style-type: none"> ◆ When the fault is reported after turning on the power several times, the servo drive has a fault. 	Replace the servo drive.

14) FU.208: FPGA System sampling operation timeout

Production mechanism:

- When FU.208 occurs, please use the internal fault code (P0B-45) to query the cause of the fault.

Reason	Confirmation way	Settlement way
1.MCU Communication timeout	<ul style="list-style-type: none"> ◆ Internal fault code P0B-45=1208: Internal chip is damaged 	Replace the servo drive.
5. Encoder communication timeout	<p>Internal fault code P0B-45=2208:</p> <ul style="list-style-type: none"> ◆ Encoder wiring error ◆ The encoder cable is loose ◆ Encoder cable is too long 	<ul style="list-style-type: none"> ◆ The cables are given priority to use our standard cables. If the cables are non-standard, check whether the cables meet the specifications and use twisted-pair shielded cables;

	<ul style="list-style-type: none"> ◆ Encoder communication is disturbed ◆ Encoder failure 	<ul style="list-style-type: none"> ◆ Check whether the plugs at both ends of the encoder are in good contact, and whether the needles are retracted, etc.; ◆ Please contact the manufacturer; ◆ Separate the strong and weak currents as far as possible, the motor cables and encoder cables should not be bundled, and the grounding of the motor and driver should be well released; ◆ Replace the servo motor.
3. Current sampling timeout	<p>Internal fault code P0B-45=3208;</p> <ul style="list-style-type: none"> ◆ Check whether there is interference from large-scale equipment on site, or whether there are multiple sources of interference such as multiple power supply and frequency conversion equipment in the cabinet; ◆ The internal current sampling chip is damaged. 	<ul style="list-style-type: none"> ◆ Separate the strong and weak currents as far as possible and do not bundle the wires on site; ◆ Replace the servo driver.
4. High precision AD conversion timeout	<p>Internal fault code P0B-45=4208;</p> <ul style="list-style-type: none"> ◆ There is interference in the high-precision AI channel wiring. Refer to the correct wiring diagram to check the AI channel wiring. 	Use twisted-pair shielded wire to re-wire to shorten the line length.
5. FPGA operation timeout	<p>Internal fault code P0B-45=0208;</p> <ul style="list-style-type: none"> ◆ Check the cause according to the reason 1/2/3/4. 	Check the cause according to the reason 1/2/3/4.

15) FU.210: Output short circuit to ground

Production mechanism:

- During the drive power-on self-test, abnormal motor phase current or bus voltage is detected.

Reason	Confirmation way	Settlement way
1. Drive power cable (U V W) is short-circuited to ground	<ul style="list-style-type: none"> ◆ Unplug the motor cable and measure whether the drive power cable U V W is short-circuited to the ground (PE). 	Rewire or replace the drive power cable
2. Motor short circuit to ground	<ul style="list-style-type: none"> ◆ After ensuring that the drive power cable and motor cable are tightly connected, respectively measure whether the insulation resistance between the U V W end of the drive and the grounding wire (PE) is a megaohm (MΩ) value. 	Replace motor
3. Drive failure	<ul style="list-style-type: none"> ◆ The drive power cable is removed from the servo drive and the fault is still reported after turning on the power several times. 	Replace servo drive

16) FU.220: Phase sequence error

Production mechanism:

- The drive performs angle identification, and it is recognized that the phase sequence of the drive UVW and the motor UVW do not match.

Reason	Confirmation way	Settlement way
The drive U V W and the motor UVW phase sequence do not correspond	<ul style="list-style-type: none"> ◆ After repeated power-on, the angle recognition still reports FU.220 fault 	Re-wire and perform angle recognition again.

17) FU.234: Speed car

Production mechanism:

- In torque control mode, the direction of torque command is opposite to the direction of speed feedback;
- In position or speed control mode, the speed feedback and speed command direction are opposite.

Reason	Confirmation way	Settlement way
1. U V W phase sequence	<ul style="list-style-type: none"> ◆ Check whether the connections between 	Wire in the correct U V W phase sequence.

wiring error	the two ends of the drive power cable and the U V W end of the motor cable and the U V W end of the drive correspond one by one.	
2. When the power is turned on, the interference signal causes the initial phase detection error of the motor rotor	◆ U V W phase sequence is correct, but the servo drive is enabled, it will report FU.234.	Power on again.
3. Wrong encoder model or wrong wiring	◆ According to the drive and motor nameplate, confirm that P00-00 (motor number) is set correctly.	Replace with matching drivers and motors. Reconfirm P00-00 (motor number), encoder wiring
4. Encoder wiring error, aging and corrosion, encoder plug loose	◆ Check whether the standard encoder cable of our company is used, and whether the cable is aging, corroded, or the connector is loose. ◆ Turn off the servo enable signal, turn the motor shaft by hand, and check whether P0B-10 changes with the rotation of the motor shaft.	Re-solder, plug tightly or replace the encoder cable.
5. Under the condition of vertical axis, the gravity load is too large	◆ Check whether the load of the vertical axis is too large, adjust the brake parameters of P02-09 ~ P02-12, and whether the fault can be eliminated	Reduce the vertical shaft load, or increase the rigidity, or shield the fault without affecting safety and use.

Note: ■ Please set P0A-12=0 to shield the running fault under the condition of being towed and vertical axis.

18) FU.400: Mechanism of electrical overvoltage in the main circuit:

- B1/⊕、⊖ 1 Between the DC bus voltage exceeds the fault value:
220V servo drive: Normal value: 310V, fault value: 420V;
380V servo drive: Normal value: 540V, fault value: 760V.

Reason	Confirmation way	Settlement way
1. The main circuit input voltage is too high	◆ Check the drive input power specification, and measure whether the input voltage of the main circuit cable drive side (L1 L2 L3) meets the following specifications: 220V drive: Effective value: 220V-240V Allowable deviation: -10%~+10% (198V~264V) 380V driver: Effective value: 380V-440V Allowable deviation: -10%~+10% (342V~484V)	Replace or adjust the power supply according to the specifications on the left.
2. The power supply is in an unstable state or is affected by a lightning strike	◆ Monitor whether the input power of the drive is affected by lightning, and measure whether the input power is stable and meet the above specifications.	After connecting the surge suppressor, connect the control power and the main circuit power again. If the fault still occurs, replace the servo drive.
3. Braking resistor failure	◆ If using the built-in braking resistor (P02-25=0), confirm whether B2 and B3 are reliably connected by wires. If so, measure the resistance between B1/⊕ and B3; ◆ If using an external braking resistor (P02-25=1/2), measure the resistance of the external braking resistor between B1/⊕ and B2. ◆ Please refer to Chapter 1 for brake resistor specifications.	If the resistance value is "∞" (infinity), the internal brake resistor is disconnected: If the built-in braking resistor is used, adjust to use an external braking resistor (P02-25=1/2), and remove the wire between B2 and B3. The resistance value and power can be selected to be consistent with the built-in braking resistor; If an external braking resistor is used, replace it with a new resistor and reconnect it between B1/⊕ and B2. Be sure to set P02-26 (power of external braking resistor) and P02-27 (resistance value of external braking resistor) to be consistent with the actual parameters of external braking

		resistor.
4. The resistance of the external braking resistor is too large, and the maximum braking energy cannot be completely absorbed	◆ Measure the resistance of the external braking resistor between B1/⊕ and B2 and compare it with the recommended value.	Change the resistance of the external braking resistor to the recommended value and reconnect it between B1/⊕ and B2. Be sure to set P02-26 (power of external braking resistor) and P02-27 (resistance value of external braking resistor) to be consistent with the actual parameters of external braking resistor.
5. When the motor is running in rapid acceleration and deceleration, the maximum braking energy exceeds the absorbable value	◆ Confirm the acceleration and deceleration time during operation, measure the DC bus voltage between B1/⊕ and I, and confirm whether the voltage exceeds the fault value during the deceleration stage.	First, ensure that the input voltage of the main circuit is within the specification range, and then increase the acceleration and deceleration time when allowed
6. The bus voltage sampling value has a large deviation	◆ Observe whether the parameter P0B-26 (bus voltage value) is in the following range: 220V driver: P0B-26 > 420V 380V driver: P0B-26 > 760V Measure whether the DC bus voltage between B1/⊕ and I is at a normal value and is less than P0B-26.	Consult our technical support.
7. Servo drive failure	◆ After several power-offs, the main circuit is reconnected, and the fault is still reported.	Replace the servo drive.

19) FU.410: Main circuit undervoltage

Production mechanism:

- B1/⊕ 、 ⊖ I DC bus voltage is lower than the fault value:
220V servo drive: Normal value: 310V, Fault value: 200V;
380V servo drive: Normal value: 540V, Fault value: 380V。

Reason	Confirmation way	Settlement way
1. The main circuit power supply is unstable or out of power	◆ Check the drive input power specifications, and measure whether the input voltage of the main circuit cable on the non-drive side and the drive side (L1 L2 L3) meets the following specifications: 220V drive: Effective value: 220V-240V Allowable deviation: -10% ~ +10% (198V~264V) 380V driver: Effective value: 380V-440V Allowable deviation: -10% ~ +10% (342V~484V) All three phases need to be measured.	Increase power supply capacity.
2. Momentary power outage		
3. Power supply voltage drops during operation	◆ Monitor the input power supply voltage of the drive to check whether the power supply of the same main circuit is turned on too much and other settings cause insufficient power supply capacity and voltage drop.	
4. If there is a phase loss, the drive that should be operated with a 3-phase power supply actually runs with a single-phase power supply	◆ Check whether the main circuit wiring is correct and reliable, and check whether the parameter P0A-00 phase failure detection is shielded.	Replace the cable and connect the main loop power cord correctly: Three phase: L1 L2 L3; single phase: L1 L2
5. Servo drive failure	◆ Observe whether the parameter P0B-26 (bus voltage value) is in the following range:	Replace the servo drive.

	220V Servo drive: P0B-26 < 200V 380V Servo drive: P0B-26 < 380V After multiple power-offs, the main circuit power (L1, L2, L3) is reconnected to still report the fault.	
--	--	--

20) FU.420: Main circuit lack of phase

Production mechanism:

- The three-phase drive lacks 1 or 2 phases.

Reason	Confirmation way	Settlement way
1. Poor wiring of three-phase input wire	◆ Check whether the cables between the non-drive side and the main circuit input terminals (L1, L2, L3) of the drive are in good condition and connect tightly	Replace the cable and connect the main loop power cord correctly
2. Three-phase drives run under single-phase power	◆ Check the drive input power specification, check the actual input voltage specification, and measure whether the main circuit input voltage meets the following specifications: 220V drive: Effective value: 220V-240V Allowable deviation: -10% ~ +10% (198V~264V) 380V driver: Effective value: 380V-440V Allowable deviation: -10% ~ +10% (342V~484V) All three phases need to be measured.	For a 0.75kW three-phase drive (drive model P01-02=5), it is allowed to run under single-phase power supply. If the input voltage meets the specifications on the left, you can set P0A-00=2 (prohibit the failure and warning of power input phase loss protection) ; In other cases, if the input voltage does not meet the specifications on the left, please replace or adjust the power supply according to the specifications on the left.
3. The three-phase power supply is unbalanced or the three-phase voltage is too low		
4. Servo drive failure	◆ After multiple power-offs, the main circuit power (L1, L2, L3) is reconnected to still report the fault.	Replace the servo drive.

21) FU.430: Control voltage undervoltage

Production mechanism:

- 220V servo drive: Normal value: 310V, Fault value: 190V;
- 380V servo drive: Normal value: 540V, Fault value: 350V.

Reason	Confirmation way	Settlement way
1. The control power supply is unstable or power failure	◆ Confirm whether it is in the process of cutting off the control power (L1C L2C) or momentary power failure occurs	Re-power on, if abnormal power failure occurs, ensure that the power supply is stable.
	◆ Measure whether the input voltage of the control cable meets the following specifications: 220V servo drive: Effective value: 220V-240V Allowable deviation: -10% ~ +10% (198V~264V) 380V driver: Effective value: 380V-440V Allowable deviation: -10% ~ +10% (342V~484V)	Increase power supply capacity.
2. Poor contact of control cable	◆ Detect whether the cable is connected, and measure whether the voltage on the driver side (L1C, L2C) of the control electric cable meets the above requirements.	Rewire or replace the cable.

22) FU.500: over speed

Production mechanism:

- The actual speed of the servo motor exceeds the overspeed fault threshold

Reason	Confirmation way	Settlement way
1. Motor cable U V W phase sequence error	◆ Check whether the connections between the two ends of the drive power cable and the U V W end of the motor cable and the U V W end of the drive correspond one by one.	Wire in the correct U V W phase sequence.
2. P0A-08 parameter setting error	◆ Check whether the over-speed fault threshold is less than the maximum motor speed required for actual operation: Over-speed fault threshold=1.2 times the maximum motor speed (P0A-08=0); over-speed fault threshold=P0A-08 (P0A-08 ≠ 0, and P0A-08 <1.2 times the maximum motor speed).	Reset the over-speed fault threshold according to the mechanical requirements.
3. The input command exceeds the overspeed fault threshold	◆ Confirm whether the motor speed corresponding to the input command exceeds the overspeed fault threshold. Position control mode, when the command source is pulse command: Motor speed (rpm)= (Input pulse frequency (HZ))/encoder resolution×electronic gear ratio×60 For this drive, Encoder resolution = 1048576(P/r)	Position control mode: When the position command source is a pulse command: under the premise of ensuring the accuracy of the final positioning, reduce the pulse command frequency or reduce the electronic gear ratio when the operating speed allows; Speed control mode: Check the input speed command value or speed limit value (P06-06 ~ P06-09), and confirm that they are all within the over-speed fault threshold; Torque control mode: Set the speed limit threshold within the overspeed fault threshold.
4. Motor speed overshoot	◆ Use the drive debugging platform to check whether the "speed feedback" exceeds the overspeed fault threshold.	Perform gain adjustment or adjust the mechanical operating conditions.
5. Servo drive failure	◆ After power on again, the fault still occurs.	Rewire or replace the cable.

23) FU.510: Pulse output overspeed

Production mechanism:

- When using the pulse output function (P05-38=0 or 1), the output pulse frequency exceeds the upper limit of the frequency allowed by the hardware (2MHz).

Reason	Confirmation way	Settlement way
The output pulse frequency exceeds the upper limit of the frequency allowed by the hardware (2MHz)	◆ When P05-38=0 (encoder frequency division output), calculate the output pulse frequency corresponding to the motor speed when the fault occurs, and confirm whether it exceeds the limit. Output pulse frequency (Hz)= $\frac{\text{Motor speed (rpm)}}{60} \times P05 - 17$	Reduce P05-17 (encoder frequency division pulse number), so that in the entire speed range required by the machine, the output pulse frequency is less than the upper limit of the frequency allowed by the hardware.
	◆ When P05-38=1 (pulse command synchronous output), the input pulse frequency exceeds 2MHz or the pulse input pin has interference. Low-speed pulse input pin: Differential input terminals: PULSE+, PULSE-, SIGN+, SIGN-, the maximum pulse frequency is 500kpps. Open collector input terminals: PULLHI, PULSE+, PULSE-, SIGN+, SIGN-, the maximum pulse frequency is 200kpps. High-speed pulse input pin: Differential input terminals: HPULSE+, HPULSE-, HSIGN+, HSIGN-, maximum pulse frequency: 2Mpps.	Reduce the input pulse frequency to the upper limit of the frequency allowed by the hardware. Please note: At this time, if the electronic gear ratio is not modified, the motor speed will decrease. If the input pulse frequency itself is high, but does not exceed the upper limit of the frequency allowed by the hardware, anti-interference measures should be taken (pulse input wiring uses twisted-pair shielded wire, set the pin filter parameter P0A-24 or P0A-30) to prevent interference. The pulse is superimposed on the real pulse command, causing a false alarm.

24) FU.602: Angle recognition failed

25) FU.610: servo drive over speed

Production mechanism:

- The accumulated heat of the drive is too high and reaches the fault threshold

26) FU.620: Motor over load

Production mechanism:

- The accumulated heat of the motor is too high and reaches the fault threshold

Reason	Confirmation way	Settlement way
1. Motor wiring and encoder wiring are wrong or bad	◆ Compare the correct "wiring diagram" and check the lines between the motor, driver, and encoder.	Connect the cables according to the correct wiring diagram; Preferentially use our standard cables; When using self-made cables, please make and connect them according to the hardware wiring instructions.
2. The load is too heavy, the effective torque of the motor output exceeds the rated torque, and it continues to run for a long time	◆ Confirm the overload characteristics of the motor or drive; ◆ Check whether the drive average load rate (P0B-12) is greater than 100.0% for a long time.	Replace the large-capacity drive and matching motor; or reduce the load, increase the acceleration and deceleration time.
3. Acceleration and deceleration are too frequent or the load inertia is large	◆ Calculate the mechanical inertia ratio or perform inertia identification, check the inertia ratio P08-15; ◆ Confirm the single operation cycle of the servo motor in cyclic operation.	Increase the acceleration and deceleration time in a single operation.
4. Improper gain adjustment or too rigid	◆ Observe whether the motor vibrates or the sound is abnormal during operation.	Re-adjust the gain.
5. Wrong drive or motor model setting	◆ For this series of products: Check the bus motor model P00-05 and the drive model P01-02.	Check the drive nameplate, set the correct drive model (P01-02) and motor model to update to a matching model.
6. The motor is blocked due to mechanical factors, resulting in excessive load during operation	◆ Displayed by the drive debugging platform or panel, confirm the running command and motor speed (P0B-00): Running command in position mode: P0B-13 (Input position command counter) Running command in speed mode: P0B-01 (Speed command) Running command in torque mode: P0B-02 (Internal torque command) Check whether the running command is not 0 and the motor speed is 0 in the corresponding mode.	Exclude mechanical factors.
7. Servo drive failure	◆ After power off, power on again, the fault is still reported.	Replace the servo drive.

Note: ■ The fault can be cleared or the power can be restarted 30s after the overload.

27) FU.625: Brake closed abnormally

Production mechanism:

- After the brake protection is turned on, the brake output signal is valid and the input command is zero for the first 100 to 500 ms, the output torque is less than 70% of the gravity load detection value.

Reason	Confirmation way	Settlement way
Motor brake is not open	◆ Confirm whether the motor brake terminal signal is valid and whether the motor brake switch is damaged.	Re-wire according to correct wiring or replace the motor.

28) FU.626: Brake opened abnormally

Production mechanism:

- After the brake protection is turned on, the output signal of the brake is invalid, but it is detected that the motor has rotated more than two revolutions at this time.

Reason	Confirmation way	Settlement way
Motor brake opens abnormally	◆ Make sure whether the signal at the motor brake terminal is valid and whether the motor brake switch is damaged.	Re-wire according to correct wiring or replace the motor.

29) FU.630: Locked-rotor motor overheat protection

Production mechanism:

- The actual speed of the motor is lower than 10rpm, but the torque command reaches the limit value and the duration reaches the set value of P0A-32.

Reason	Confirmation way	Settlement way
1. Drive U V W output phase loss or phase sequence is connected wrong	◆ Carry out a test run of the motor under no load and check the wiring.	Re-wire according to correct wiring or replace the cable.
2. Drive U V W output disconnection or encoder disconnection	◆ Check cable wire	Re-wire according to correct wiring or replace the cable.
3. The motor is blocked due to mechanical factors	◆ Displayed by the drive debugging platform or panel, confirm the running command and motor speed (P0B-00): Running command in position mode: P0B-13 (Input position command counter) Running command in speed mode: P0B-01 (Speed command) In torque mode Run command: P0B-02 (Internal torque command) Check whether the running command is not 0 and the motor speed is 0 in the corresponding mode.	Troubleshoot mechanical factors.

30) FU.650: Radiator overheated

Production mechanism:

- The temperature of the drive power module is higher than the over-temperature protection point.

Reason	Confirmation way	Settlement way
1. The ambient temperature is too high	◆ Measure the ambient temperature	Improve the cooling conditions of the servo drive and lower the ambient temperature.
2. After overload, reset the overload fault by turning off the power, and repeat it many times	◆ Check the fault record (set P0B-33, check P0B-34), whether there is an overload fault or warning (FU.610, FU.620, FU.630, FU.650, FU.909, FU.920, FU.922).	Change the fault reset method, wait 30s after overload, and then reset. Increase the drive and motor capacity, increase the acceleration and deceleration time, and reduce the load.
3. The fan is broken	◆ Whether the fan is running during operation.	Replace the servo drive.
4. The installation direction of the servo drive and the interval with other servo drives are unreasonable	◆ Confirm whether the installation of the servo drive is reasonable.	Install according to the installation standard of the servo drive.
5. Servo drive failure	◆ The fault will still be reported after 5 minutes of power failure.	Replace the servo drive.

31) FU.731: Encoder battery failure

Production mechanism:

- The encoder battery voltage of the multi-turn absolute encoder is too low or the battery is not connected.

Reason	Confirmation way	Settlement way
During power failure, the battery was not connected	◆ Confirm whether it is connected during power failure	Set P0D-20=1 to clear the fault
Encoder battery voltage is	◆ Measure battery voltage	Replace with a new battery that matches the

too low		voltage
---------	--	---------

Note: ■ This fault only occurs when the multi-turn absolute position function is enabled (P0201=1 or 2).

32) FU.733: Encoder multi-turn counting error.

Production mechanism:

- Encoder multi-turn counting error.

Reason	Confirmation way	Settlement way
Encoder failure	◆ Setting P0D-20=1 Clear the fault, FU.733 still occurs after power-on again	Replace the motor

33) FU.735: Encoder multi-turn counting overflow

Production mechanism:

- Detection of encoder multi-turn counting overflow.

Reason	Confirmation way	Settlement way
When P02-01=1, detect encoder multi-turn counting overflow	-	Set P0D-20=1 to clear the fault and power on again

34) FU.740: Encoder interference

Production mechanism:

- The Z signal of the encoder is interfered, causing the electrical angle corresponding to the Z signal to change too much.

Reason	Confirmation way	Settlement way
1. Encoder wiring error	◆ Check the encoder wiring.	Re-wiring according to the correct wiring diagram
2. The encoder cable is loose	◆ Check whether the on-site vibration is too large, causing the encoder cable to loosen, or even vibration to the encoder.	Re-wire and ensure that the encoder terminal is tightly connected.
3. Encoder Z signal is interfered	<ul style="list-style-type: none"> ◆ Check the wiring on site: Whether there is interference from large-scale equipment around, or whether there are multiple sources of interference such as multiple power supply frequency conversion equipment in the cabinet. ◆ Put the servo in the "Rdy" state, manually rotate the motor shaft counterclockwise to monitor whether P0B-10 (electrical angle) increases or decreases smoothly, and one circle corresponds to 5 0-360°. (Refer to Z series motor, if it is X series motor, 4 0-360°). If there is an abnormal sudden change in P0B-10 during rotation, the encoder itself has a serious problem. If there is no alarm during rotation, but the alarm occurs during servo operation, the possibility of interference is high. 	<p>The cables are given priority to use our standard cables; If the wiring is not standard, check whether the cable meets the specifications and whether it uses twisted-pair shielded wire. Separate the strong and weak currents as much as possible, and do not bundle the motor cables and encoder cables. The ground contact between the motor and the driver is good. Check whether the plugs at both ends of the encoder are in good contact, and whether the needles are retracted.</p>
4. Encoder failure	<ul style="list-style-type: none"> ◆ Replace the encoder cable that can be used normally. If the failure no longer occurs after replacement, the original encoder cable is damaged. ◆ Put the motor at the same position, power on several times and check P0B-10, the electrical angle deviation should be within $\pm 30^\circ$. 	<p>Replace the encoder cable that can be used normally. If not, the encoder itself has a serious problem and the servo motor needs to be replaced.</p>

35) FU.834: AD Sampling overvoltage fault

Production mechanism:

- AI the sampled value is greater than 11.5V.

Reason	Confirmation way	Settlement way
1. AI channel input voltage is too high	◆ Measure the input voltage of the AI channel and check whether the actual sampled voltage (P0B-21 or P0B-22) is greater than 11.5V	Check the sampled voltage while adjusting the input voltage until the sampled voltage does not exceed 11.5V.
2. AI channel wiring error or interference	◆ Refer to the correct wiring diagram to check the AI channel wiring	Re-wiring with twisted-pair shielded wire to shorten the line length Increase the AI channel filter time constant: AI1 filter time constant: P03-51 AI2 filter time constant: P03-56

36) FU.835: High-precision AD sampling failure

Production mechanism:

- High-precision AD circuit is interfered

Reason	Confirmation way	Settlement way
1. High-precision AI channel wiring has interference	◆ Refer to the correct wiring diagram to check the AI channel wiring	Re-wiring with twisted-pair shielded wire to shorten the line length

37) FU.A33: Encoder data is abnormal

Production mechanism:

- The internal parameters of the encoder are abnormal.

Reason	Confirmation way	Settlement way
1. The cable of the bus-type incremental encoder is broken or loose	◆ Check cable wire	Check whether the encoder cable is incorrectly connected, or if the wire is broken or the contact is poor. If the motor cable and the encoder cable are bundled together, please separate the wiring.
2. The parameter reading and writing of the bus type incremental encoder is abnormal	◆ If the fault is still reported after turning on the power several times, the encoder has a fault.	Replace the motor

38) FU.B00: Position deviation is too large

Production mechanism:

- In position control mode, the position deviation is greater than the set value of P0A-10.

Reason	Confirmation way	Settlement way
1. Drive U V W output phase loss or phase sequence is connected wrong	◆ Carry out a test run of the motor under no load and check the wiring.	Re-wire according to correct wiring or replace the cable.
2. Drive U V W output disconnection or encoder disconnection	◆ Check cable wire	Re-wiring, the servo motor power cable and the drive power cable UVW must correspond one-to-one. If necessary, replace with a new cable and ensure its reliable connection.
3. The motor is blocked due to mechanical factors	◆ Displayed by the drive debugging platform or panel, confirm the running command and motor speed (P0B-00): Running command in position mode: P0B-13 (Input position command counter) Running command in speed mode: P0B-01 (speed command) Running command in torque mode: P0B-02 (internal torque command)	Troubleshoot mechanical factors.

	<p>Check whether the running command is not 0 and the motor speed is 0 in the corresponding mode.</p>	
4. Servo drive gain is low	<p>◆ Check the position loop gain and speed loop gain of the servo drive: The first gain: P08-00~P08-02 Second gain: P08-03~P08-05</p>	Perform manual gain adjustment or automatic gain adjustment.
5. High input pulse frequency	<p>◆ When the position command source is pulse command, whether the input pulse frequency is too high. ◆ The acceleration/deceleration time is 0 or too small.</p>	<p>Reduce the position command frequency or reduce the electronic gear ratio. When using the host computer to output position pulses, a certain acceleration time can be set in the host computer; If the host computer cannot set the acceleration and deceleration time, increase the position command smoothing parameters P05-04 and P05-06.</p>
6. Relative to the operating conditions, the fault value (P0A-10) is too small	<p>◆ Confirm whether the position deviation fault value (P0A-10) is set too small.</p>	Increase the set value of P0A-10.
7. Servo drive /servo motor error	<p>◆ Monitor the running waveform through the oscilloscope function of the drive debugging platform: Position command, position feedback, speed command, torque command.</p>	If the position command is not zero and the position feedback is always zero, please replace the servo driver/motor.

39) FU.B01: Pulse input abnormal

Production mechanism:

- The input pulse frequency is greater than the maximum position pulse frequency (P0A-09).

Reason	Confirmation way	Settlement way
1. The input pulse frequency is greater than the set maximum position pulse frequency (P0A-09)	<p>◆ Check whether P0A-09 (maximum position pulse frequency) is less than the maximum input pulse frequency required when the machine is running normally.</p>	Reset P0A-09 according to the maximum position pulse frequency required during normal operation of the machine. If the output pulse frequency of the upper computer is greater than 4MHz, the output pulse frequency of the upper computer must be reduced.
2. Input pulse interference	<p>◆ First, use the oscilloscope function of the drive debugging platform software to check whether there is a sudden increase in the position command, or check whether the servo drive input position command counter (P0B-13) is greater than the number of pulses output by the host computer. ◆ Then, check the grounding of the circuit.</p>	<p>First of all, the pulse input cable must use twisted-pair shielded cable and be routed separately from the drive power cable. Secondly, use the low-speed pulse input port (P05-01=0), when the differential input is selected, the "ground" of the host computer must be reliably connected to the "GND" of the driver; When selecting open-collector input, the "ground" of the host computer must be reliably connected to the "COM" of the driver; Use high-speed pulse input port (P05-01=1), only differential input can be used, and the "ground" of the host computer must be reliably connected to the "GND" of the driver. Finally, according to the selected hardware input terminal, increase the pin filter time P0A-24 or P0A-30 of the pulse input terminal.</p>

40) FU.B02: Full closed loop position deviation is too large

Production mechanism:

- The absolute value of the full closed loop position deviation exceeds P0F-08 (full closed loop position deviation too large threshold).

Reason	Confirmation way	Settlement way
--------	------------------	----------------

1. Drive U V W output phase loss or phase sequence is connected wrong	◆ Carry out a test run of the motor under no load and check the wiring.	Re-wire according to correct wiring or replace the cable.
2. Drive U V W output disconnection or internal/external encoder disconnection	◆ Check cable wire	Re-wiring, the servo motor power cable and the drive power cable UVW must correspond one-to-one. If necessary, replace with a new cable and ensure its reliable connection.
3. The motor is blocked due to mechanical factors	◆ Displayed by the drive debugging platform or panel, confirm the running command and motor speed (P0B-00): Running command in position mode: P0B-13 (Input position command counter) Running command in speed mode: P0B-01 (Speed command) Running command in torque mode: P0B-02 (Internal torque command) Check whether the running command is not 0 and the motor speed is 0 in the corresponding mode.	Troubleshoot mechanical factors.
4. Servo drive gain is low	◆ Check the position loop gain and speed loop gain of the servo drive: The first gain: P08-00~P08-02 Second gain: P08-03~P08-05	Perform manual gain adjustment or automatic gain adjustment
5. High input pulse frequency	◆ When the position command source is pulse command, whether the input pulse frequency is too high. ◆ The acceleration/deceleration time is 0 or too small.	Reduce the position command frequency or reduce the electronic gear ratio. When using the host computer to output position pulses, a certain acceleration time can be set in the host computer; If the host computer cannot set the acceleration and deceleration time, increase the position command smoothing parameters P05-04 and P05-06.
6. Relative to operating conditions, the fault value (P0F-08) is too small	Confirm the fault threshold of the full closed loop position deviation is too large (P0F-08) is the setting too small	Increase P0F-08 setting value
7. Servo drive / Motor failure	◆ Monitor the running waveform through the oscilloscope function of the drive debugging platform: Position command, position feedback, speed command, torque command.	If the position command is not zero and the position feedback is always zero, please replace the servo drive/motor.

41) FU.B03: Electronic gear setting over run

Production mechanism:

- Any group of electronic gear ratio exceeds the limit value:
($0.001 \times \text{encoder resolution} / 10000$, $4000 \times \text{encoder resolution} / 10000$).

Reason	Confirmation way	Settlement way
The electronic gear ratio setting value exceeds the above range	◆ If P05-02=0, determine the ratio of parameters P05-07/P05-09 and P05-11/P05-13 ◆ If P05-02>0, confirm: encoder resolution / ratio of P05-02, P05-07/P05-09, P05-11/P05-13	Encoder resolution /P05-02, P05-07/P05-09, P05-11/P05-13 The ratio is set within the above range.
Parameter change order problem	◆ Change related parameters of electronic gear ratio: For P05-02, P05-07/P05-09, P05-11/P05-13, the electronic gear ratio exceeds the limit due to the unreasonable change sequence during the transition process of calculating the electronic gear	Use the fault reset function or re-power on.

	ratio.	
--	--------	--

42) FU.B04: Full closed loop function parameter setting error

Production mechanism:

- When the full closed loop function is used and the position command source is an internal position command, the internal and external loop switching function is used.

Reason	Confirmation way	Settlement way
In the fully closed loop position mode, the position command source is the internal position command, but the internal and external loop switching mode is used	<ul style="list-style-type: none"> ◆ Check if P0F-00 is 2; ◆ Confirm whether the source of position command is internal position command: multi-segment position command, interrupt fixed length function. 	When the full-closed loop function is used and the position command source is an internal position command, only the external encoder feedback mode can be used, that is, P0F-00 can only be 1.

43) FU.D03: CAN Communication connection is interrupted

Production mechanism:

- CAN Communication timed out.

Reason	Confirmation way	Settlement way
CAN Communication connection interrupted: slave station dropped	<ul style="list-style-type: none"> ◆ Check the status of the main station PLC CAN communication card light: The ERR light of the master PLC flashes at a frequency of 1 Hz, and some of the ERR lights of the slave PLCs are on (when using the PLC background software, you can monitor D78xx in the component monitoring table of the master. xx represents the station number, decimal, part The corresponding D78xx of the configured station is 5, which means that the slave station is faulty) 	Check the connection of the communication cable between the slave station with the ERR light on and the master station; Check the communication baud rate P0C-08 of the slave station with the ERR light on and adjust it to be consistent with the master station.
CAN Communication connection is interrupted: the master station drops	<ul style="list-style-type: none"> ◆ Check the status of the main station PLC CAN communication card light: The ERR lights of all slave PLCs are always on (when using the PLC background software, D78xx can be monitored in the component monitoring table of the master station, xx represents the station number, in decimal, all D78xx corresponding to all configured stations are all 5 indicating that the master station has occurred malfunction). 	Check the cable connection of the master station.

7.2.3 How to deal with warnings

1) FU.110: Frequency division pulse output setting failure

Production mechanism:

- When using the encoder frequency division output function (P05-38=0), the set encoder frequency division pulse number does not meet the threshold determined by the encoder specification

Reason	Confirmation way	Settlement way
Encoder frequency division pulse number does not meet the range	<ul style="list-style-type: none"> ◆ Incremental code disc: the frequency division pulse number of the encoder cannot exceed the resolution of the encoder; 17bit bus type incremental encoder, resolution 1048576 (P/r); 2500 line incremental encoder, resolution 10000 (P/r); ◆ Absolute code disc: The number of pulses of the encoder frequency division cannot exceed 1/4 of the encoder resolution. 	Reset the encoder frequency division pulse number (P05-17) so that it meets the specified range.

2) FU.601: Back to origin timeout failure

Production mechanism:

- When using the origin return function (P05-30=1~5), the origin is not found within the time set by P05-35.

Reason	Confirmation way	Settlement way
1. Origin switch failure	<ul style="list-style-type: none"> ◆ When returning to origin, it is always searching at high speed without low speed searching process. ◆ After the origin return high-speed search, it has been in the reverse low-speed search process. 	<p>If you are using hardware DI, confirm that the DI function 31 has been set in group P03, and then check the DI terminal wiring. When the DI terminal logic is changed manually, monitor whether the driver receives the corresponding DI level change through P0B-03. If not, it means that the DI switch wiring is wrong; if it is, it means there is an error in the home return operation. Please refer to section 6.2.8 to operate this function correctly.</p> <p>If you are using virtual DI, refer to 10.4 to check whether the VDI use process is correct.</p>
2. Limit the time to find the origin is too short	<ul style="list-style-type: none"> ◆ Check whether the time set in P05-35 is too short 	Increase P05-35
3. The speed of the high-speed search origin switch signal is too low	<ul style="list-style-type: none"> ◆ Check the distance between the home position and the origin switch to determine whether the speed value set by P05-32 is too small, resulting in too long time to find the origin switch 	Increase P05-32

3) FU.730: Encoder battery warning

Production mechanism:

- The encoder battery voltage of the multi-turn absolute encoder is too low or the battery is not connected.

Reason	Confirmation way	Settlement way
During power failure, the battery was not connected	<ul style="list-style-type: none"> ◆ Confirm whether it is connected during power failure 	Replace with a new battery that matches the voltage
Encoder battery voltage is too low	<ul style="list-style-type: none"> ◆ Measure battery voltage 	

Notes: ■ This fault only occurs when the multi-turn absolute position function is enabled (P0201=1 or 2).

4) FU.831: AI Zero drift is too large

Production mechanism:

- AI(includes AI1 and AI2) when the terminal input voltage is 0V, the voltage sampled by the driver is greater than 500mV.

Reason	Confirmation way	Settlement way
1. Wiring error or interference	<ul style="list-style-type: none"> ◆ Check the wiring with reference to the correct wiring diagram. 	<p>Use twisted-pair shielded wire to re-wire to shorten the line length.</p> <p>Increase the AI channel filter time constant: AI1 filter time constant: P03-51 AI2 filter time constant: P03-56</p>
2. Servo drive error	<ul style="list-style-type: none"> ◆ Remove the external wiring of the AI terminal (input is 0), and check whether the AI sampling value of group P0B exceeds 500mV. 	If it exceeds, replace the drive.

5) FU.900: DI Urgent brake

Production mechanism:

- DI function 34(FunIN.34: brake, Emergency) The corresponding DI terminal logic is valid (including hardware DI and virtual DI).

Reason	Confirmation way	Settlement way
DI function 34: brake, Is triggered	<ul style="list-style-type: none"> ◆ Check DI function 34: Emergency Stop brake, and whether its corresponding DI terminal logic is set to valid. 	Check the operating mode, and on the premise of confirming safety, release the DI brake valid signal.

6) FU.909: Motor overload warning

Production mechanism:

- 60Z series 200W and 400W motor, the accumulated heat of the motor is too high and reaches the warning value.

Reason	Confirmation way	Settlement way
1. Wrong or bad motor wiring and encoder wiring	◆ Compare the correct wiring diagram and check the wiring between the motor, driver, and encoder.	Connect the cables according to the correct wiring diagram; Preferentially use our standard cables; When using self-made cables, please make and connect them according to the hardware wiring instructions.
2. The load is too heavy, the effective torque of the motor output exceeds the rated torque, and it continues to run for a long time	◆ Confirm the overload characteristics of the motor or drive; ◆ Check whether the drive average load rate (P0B-12) is greater than 100.0% for a long time.	Replace the large-capacity drive and matching motor; Or reduce the load and increase the acceleration and deceleration time.
3. Acceleration and deceleration are too frequent or the load inertia is too large	◆ Check the mechanical inertia ratio or perform inertia identification, and check the inertia ratio P08-15. ◆ Confirm the single operation cycle of the servo motor in cyclic operation.	Increase the acceleration and deceleration time.
4. Improper gain adjustment or excessive rigidity	◆ Observe whether the motor vibrates or the sound is abnormal during operation.	Re-adjust the gain.
5. Wrong drive or motor model setting	◆ For this series of products: Check the bus motor model P00-05 and the drive model P01-02.	Check the drive nameplate, set the correct drive model (P01-02) and update the motor model to a matching model.
6. The motor is blocked due to mechanical factors, resulting in excessive load during operation	◆ Use the drive debugging platform or panel to view the running command and motor speed (P0B-00): Running command in position mode: P0B-13 (Input position command counter) Running command in speed mode: P0B-01 (Speed command) Running command in torque mode: P0B-02 (Internal torque command) Check whether the running command is not 0 or very large in the corresponding mode, and the motor speed is 0.	Exclude mechanical factors.
7. Servo drive failure	◆ After power off, power on again.	Please replace the servo drive if the fault is reported after power-on again.

7) FU.920 :Braking resistor overload alarm

Production mechanism:

- The cumulative heat of the braking resistor is greater than the set value

Reason	Confirmation way	Settlement way
1. The connection of the external brake resistor is bad, dropped or broken	◆ Remove the external braking resistor, and directly measure whether the resistance value is "∞" (infinity); ◆ Measure whether the resistance between B1/⊕ and B2 is "∞" (infinity).	Replace with a new external braking resistor. After the measured resistance value is consistent with the nominal value, connect it between B1/⊕ and B2.
		Choose a good cable and connect both ends of the external braking resistor between B1/⊕ and B2.
2. When using the built-in braking resistor, the cable between the power terminals B2 and B3 is short or disconnected	◆ Measure whether the resistance between B2 and B3 is "∞" (infinity).	Connect B2 and B3 directly with a good cable.

3. When using an external braking resistor, the selection of P02-25 (brake resistor setting) is wrong	<ul style="list-style-type: none"> ◆ View the parameter value of P02-25; ◆ Measure the resistance value of the external resistor between B1/⊕ and B2 actually selected, and compare it with the brake resistor specification table to see if it is too large; ◆ Check whether the parameter value of P02-27 is greater than the resistance value of the external resistance between B1/⊕ and B2 actually selected. 	Setting correct P02-25: P02-25=1 (use external resistor, natural cooling) P02-25=2 (Use external resistor, forced air cooling)
4. When using an external braking resistor, the actually selected external braking resistor resistance is too large		Refer to the braking resistor specification table and select the resistor with the proper resistance value correctly.
5.P02-27 (resistance value of external braking resistor) is greater than the actual resistance value of external braking resistor		Set P02-27 to be consistent with the actual selection of external resistance.
6. The input voltage of the main circuit exceeds the specification range	<ul style="list-style-type: none"> ◆ Measure whether the input voltage of the main circuit cable driver side meets the following specifications: 220V drive: Effective value: 220V~240V Allowable deviation: -10% ~ +10% (198V~264V) 380V driver: Effective value: 380V~440 Allowable deviation: -10%~+10% (342V~484V) 	Adjust or replace the power supply according to the specifications on the left.
7. The load moment of inertia ratio is too large	<ul style="list-style-type: none"> ◆ Identify the moment of inertia; or manually calculate the total moment of inertia according to the mechanical parameters; ◆ Whether the actual load inertia ratio exceeds 30. 	Select a large-capacity external braking resistor, and set P02-26 to be consistent with the actual value; Use large-capacity servo driver; If allowed, reduce the load; If allowed, increase the acceleration and deceleration time; If allowed, increase the motor running cycle.
8. The motor speed is too high, the deceleration process is not completed within the set deceleration time, and it is in continuous deceleration state during periodic movement	<ul style="list-style-type: none"> ◆ View the speed curve of the motor during periodic movement, and check whether the motor is decelerating for a long time. 	
9. The capacity of the servo drive or the capacity of the braking resistor is insufficient	<ul style="list-style-type: none"> ◆ Check the single cycle speed curve of the motor and calculate whether the maximum braking energy can be completely absorbed. 	
10. Servo drive failure	-	Replace the drive.

8) FU.922: External braking resistor is too small

Production mechanism:

- P02-27(External braking resistor)<P02-21(The drive allows the minimum value of external braking resistor)

Reason	Confirmation way	Settlement way
When using an external braking resistor (P02-25=1 or 2), the resistance of the external braking resistor is less than the minimum value allowed by the drive	<ul style="list-style-type: none"> ◆ Measure the resistance of the external braking resistor between B1/⊕ and B2 to confirm whether it is less than P02-21. 	If it is, replace it with an external braking resistor that matches the driver. After setting P02-27 to the selected resistance value, connect both ends of the resistor between B1/⊕ and B2; If not, set P02-27 to the actual resistance value of the external braking resistor.

9) FU.939: Motor power line is broken

Production mechanism:

- The actual phase current of the motor is less than 10% of the rated current, and the actual speed is low,

but the internal torque command is large.

Reason	Confirmation way	Settlement way
Motor power line is broken	<ul style="list-style-type: none"> Check whether the phase current effective value (P0B-24) and the internal torque command (P0B-02) are more than 5 times different, and the actual motor speed (P0B-00) is less than 1/4 of the motor rated speed. 	Check the wiring of the motor power cable, reconnect it, and replace the cable if necessary.

10) FU.941: Change parameters need to be re-powered to take effect

Production mechanism:

- When the "effective time" of the function code attribute of the servo drive is "power on again", after the parameter value of the function code is changed, the drive reminds the user to power on again.

Reason	Confirmation way	Settlement way
Change the function code that will take effect after powering on again	<ul style="list-style-type: none"> Confirm whether the function code whose "effective time" is "re-power on" is changed. 	Power on again.

11) FU.942: Frequent parameter storage

Production mechanism:

- The number of function codes modified at the same time exceeds 200

Reason	Confirmation way	Settlement way
Very frequently and a large number of function code parameters are modified and stored in EEPROM (P0C-13=1)	Check whether the host computer system frequently and quickly modify the function code.	Check the operating mode. For parameters that do not need to be stored in the EEPROM, set P0C-13 to 0 before the host computer writes.

12) FU.950: Forward overtravel warning

Production mechanism:

- DI function 14(FunIN.14: P-OT, Forward overtravel switch) The corresponding DI terminal logic is valid.

Reason	Confirmation way	Settlement way
DI function 14: Prohibit forward drive, terminal logic is valid	<ul style="list-style-type: none"> Check whether the DI terminal of group P03 is set to DI function 14; Check whether the DI terminal logic of the corresponding bit of the input signal monitoring (P0B-03) is valid. 	Check the operating mode, and on the premise of ensuring safety, give a negative command or rotate the motor to make the "positive overtravel switch" terminal logic invalid.

13) FU.952: Reverse overtravel warning

Production mechanism:

- DI function 15(FunIN.15: N-OT, Reverse overtravel switch) the corresponding DI terminal logic is valid.

Reason	Confirmation way	Settlement way
DI function 15 : Reverse drive is prohibited, and the terminal logic is valid.	<ul style="list-style-type: none"> Check whether DI function 15 is set for the DI terminal of group P03; Check whether the DI terminal logic of the corresponding bit of the input signal monitoring (P0B-03) is valid. 	Check the operating mode, and if it is safe, give a negative command or rotate the motor to make the "reverse overtravel switch" terminal logic invalid.

14) FU.980: Encoder internal fault

Production mechanism:

- The encoder algorithm is incorrect.

Reason	Confirmation way	Settlement way
--------	------------------	----------------

Encoder internal fault	◆ When the fault is reported after turning on the power several times, the encoder has a fault.	Replace the drive.
------------------------	---	--------------------

15) FU.990: Input phase loss warning

Production mechanism:

- The drives below 1kW are allowed to operate in single phase, but the power input phase loss fault and warning (P0A-00) are enabled.

Reason	Confirmation way	Settlement way
P0A-00=1 (Power input phase loss protection selection: enable fault and warning), for a 0.75kW three-phase drive (drive model P01-02=5), it is allowed to run under single-phase power, and a warning will be reported when single-phase power is connected.	◆ Confirm whether it is a three-phase drive that allows single-phase operation	If it is actually a three-phase drive, and the main circuit power line is connected to a three-phase power supply, it still reports a warning, then proceed as FU.420; If it is actually a three-phase specification drive and single-phase operation is allowed, and the main circuit power line is connected to a single-phase power supply, a warning is still reported, set P0A-00 to 0.

16) FU.994: CAN Address conflict

Reason	Confirmation way	Settlement way
CANlink Address conflict	◆ Confirm whether there is duplicate allocation among slave stations P0C-00	Assign each slave address to ensure that P0C-00 is not repeated.

7.2.4 Inner fault

Please contact our technicians when the following failures occur.

FU.602: Angle recognition failed;

FU.220: phase sequence error;

FU.A40: Parameter identification failed;

FU.111: Servo internal parameters are abnormal