

MEMS Mass Flow Meters

MF4000 Series

User Manual

Document No. 01-2017-M1 EN

Issue date: 2017.01

Revision: VB.7

:

Tel

Email VDOHV DWR FRP

Contents

Features.....	2
Introduction.....	2
Applications.....	2
Working Principle and Package.....	3
Schematic of Electronics	3
The Meters	4
Specifications.....	4
Description.....	4
Dimensions.....	5
Product Selection.....	5
Installation and User Interface.....	5
Running Mode.....	6
Instant flow rate mode	
Flow accumulation mode	
Maximum / minimum mode	
Menu Setting Mode.....	7
Keyboard lock	
Flow accumulation reset	
Automatic offset calibration	
Response time setting	
Display refresh setting	
Maximum / minimum flow rate record clearing	
System default retrieval	
Decimal setting	
Safety and Maintenance.....	9
Wetted materials and compatibility	
Safety precautions	
Customer Service and Order.....	10
Appendix RS232/RS485 Communication Protocol.....	11

MEMS Mass Flow Meters

Model MF4000

Features

- Designed for gas flow in fixed flow channel of 3 mm and 8 mm, with accumulated flow
- Compact design ready for manifold applications
- Fast response time provides solutions for critical applications
- Excellent for electronic meters in anesthesia equipments
- Exchangeable mechanical connectors for easy installation at different applications
- Intrinsic safe enclosure for wide applications
- Low power consumption, can be operated by battery



Introduction

MF4000 Series mass flow meters are designed for applications in gas flow within a flow channel diameter of 3 mm and 8 mm, respectively. The compact design provides user friendly installation for multiple flow channel sensing requirements. Plastic finishing with an easy change of the mechanical adaptors enables applications with different connection thread requirements or one-touch approach. The meters can be used for electronic meters in anesthesia equipments, environmental samplers and many other industrial applications.

The meters can be customized with flow range, gas specific requirements, user interface and others upon requests to the manufacturer.

Applications

- Environmental Monitoring
- Aeration cable
 - Gas generated plasma monitor
 - Vacuum applications
 - Preservation of oxygen devices
 - Anesthesia
 - Ventilator
 - Ventilation equipment detection devices
 - Other industrial applications such as welding

Working Principle and Package

The MEMS calorimetric sensor is installed at the flow channel wall forming a plate that serves as an additional flow conditioner from the boundary layer configuration resulting in a laminar flow. The mass flow measurement is established as the fluid carries heat away from the heater causing the redistribution of the temperature field. Accurate flow rate is obtained by calibration with the standard fluid at the preset conditions.

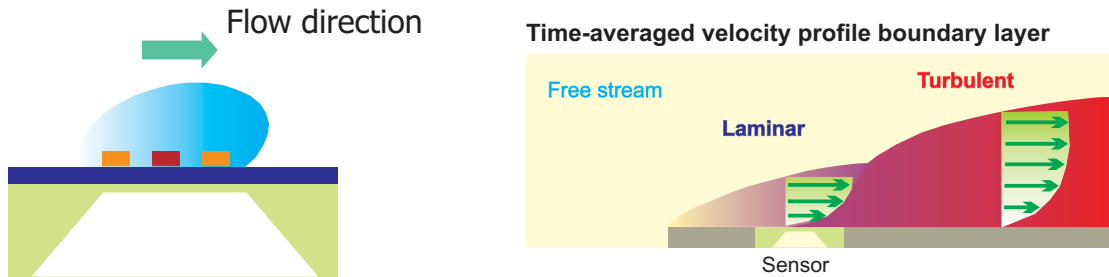

Schematic of Electronics

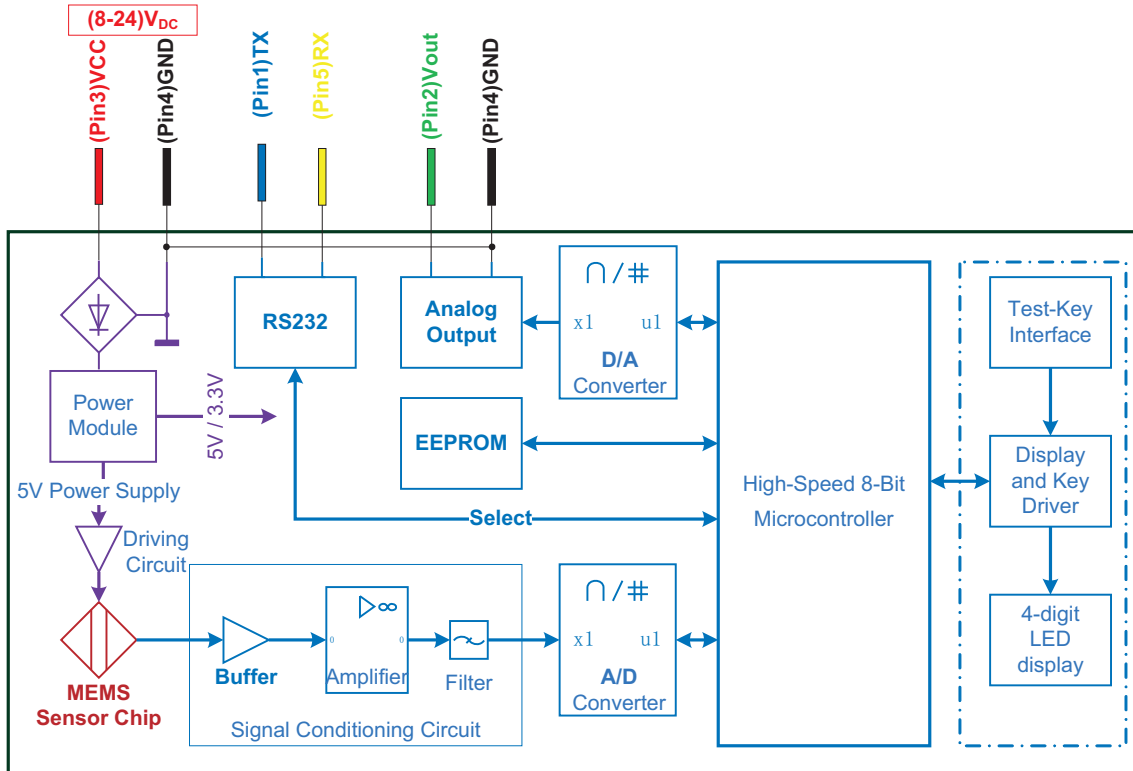

The Meters

The meters is packaged into the standard poly-carbonate enclosure with which the maximum detectable mass flow rate can be customized within 2 SLPM to 50 SLPM by modification of the circuitry so that the various flow can be achieved to meet customers' best requirements. The calibration is done with air at 20°C and 1 bar pressure. It can nonetheless be calibrated at other customer specific conditions upon requests.

Specifications

	MF4003	MF4008	
DN	3	8	mm
Flowrate Range	0 ~ 2, 3, 4, 5	0 ~ 10, 20, 30, 40, 50	SLPM
Turn-down	>100:1		
Accuracy	±(1.5+0.2FS)		%
Repeatability	0.25		%
Null Shift	±30		mV
Output Shift	0.12		% / °C
Response Time	100 (Default, 10, 20, 50, 200 ,500, 1000 selectable)		ms
Power Supply	8~24Vdc, 50mA		
Output	Linear; RS232 / RS485, Analog 0.5~4.5Vdc		
Display	4-digit, 7-segment LED , 2 Status LED		
Units	Instant flow rate: SLPM; Flow accumulation: SL		
Display Resolution	0.001, 0.01, 0.1 selectable	0.01, 0.1 selectable	SLPM
Pressure Drop	100	600	Pa
Max. Pressure	0.5		MPa
Working Temperature	-10~+55		°C
Storage Temperature	-20~+65		°C
Humidity	<95%RH (No icing or condensation)		%RH
Mechanical Connection	BSPT 1/4 (R 1/4), 4mm / 6mm / 8mm One-touch	BSPT 1/4 (R 1/4)	
Keyboard	3 keys		
Pins Out	5 Pins, NS-TECH CD R-5		
Calibration	Air @ 20°C, 101.325kPa		
Package	Polycarbonate		
Weight	55 (with BSPT 1/4 (R 1/4) connection) 74(with O4,O8 connection), 71(with O6 connection)		g

Description

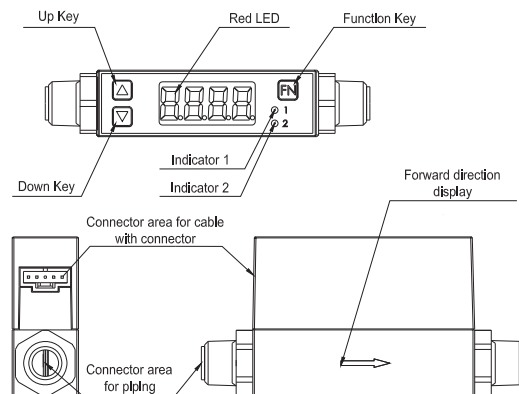

Dimensions

For R 1/4 connection

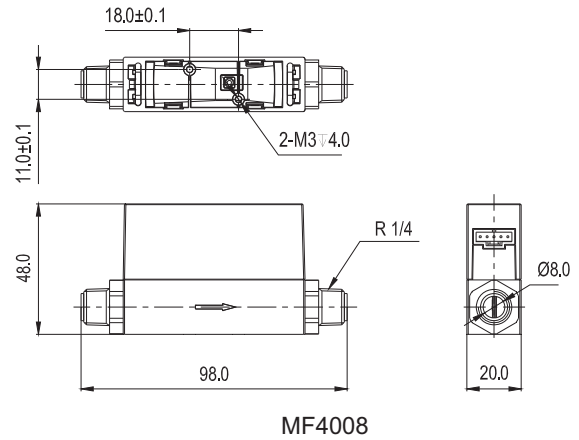
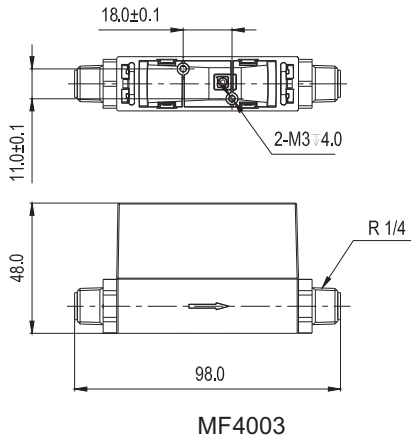

For One-touch connection

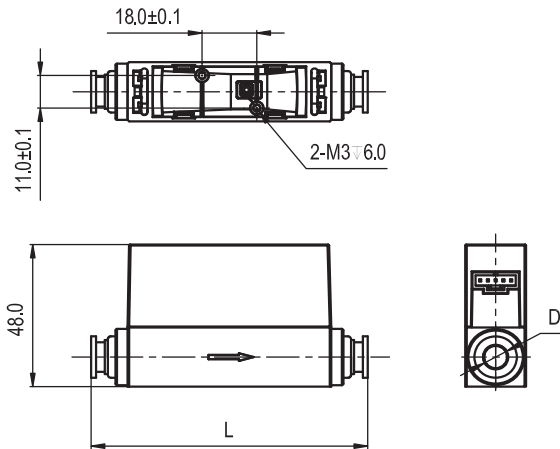

One-touch Connection	L	D
ID=8mm	91.0	Ø8.0
ID=6mm	83.0	Ø6.0
ID=4mm	80.0	Ø4.0

Product Selection

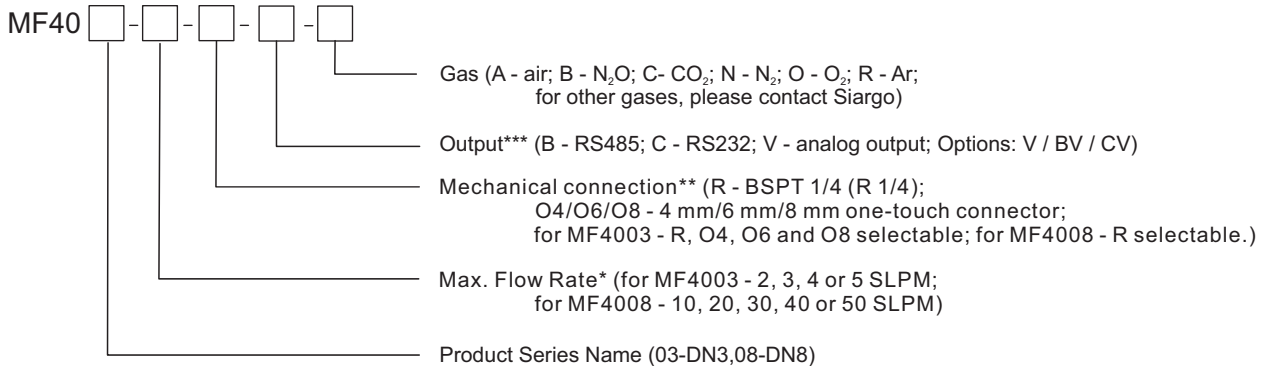

* Max. flow rate number only, for example, 5 meaning full scale flow rate of 5 SLPM.

For CO₂ and N₂O, selectable: 2, 3 or 4 SLPM (without 5 SLPM) for MF4003; 10, 20, 30 or 40 SLPM (without 50 SLPM) for MF4008;

** The meter standard output is analog. Digital outputs are optional.

Installation and User Interface

The product at the time of shipment is fully inspected for product quality and meets all safety requirements. Additional safety measures during the installation should be applied. This includes, but is not limited to leakage verification procedures if applicable, standard ESD (electrostatic discharge) precautions, and DC voltage precautions. Other tasks such as calibration, part replacement, repair, and maintenance must only be performed by trained personnel. Upon requests, manufacturer will provide necessary technical support and/or training of the personnel.

Do not open the product cover or alter any part of the product. Any such actions will forfeit the terms of the warranty and cause the liability to any damages thereafter.

The interface is defined in the table below:

Pin	Colour	Definition
1	Blue	TX, RS232 Transmit (output) / RS485B
2	Green	Vout, Analog output
3	Red	VCC, Power supply (8 - 24 Vdc)
4	Black	GND, Ground
5	Yellow	RX, RS232 Receive (input) / RS485A

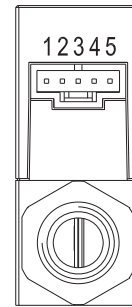

NOTE: Upon open the package, if any component listed above is missing or any visible mechanical damage is found, please contact supplier or distributors immediately. For additional assistance of installation, please contact supplier or customer service.

Running Mode

The display consists of a 4-digit LED panel and two LED indicators (i.e., I-LED and II-LED). Under the running mode, the 4-digit LED panel will show Instant flow rate, flow accumulation, or maximum/minimum flow rates. There are three different display modes: instant flow rate mode, flow accumulation mode, and maximum/minimum mode. The two LED indicators will illustrate which display mode is undergoing.

F

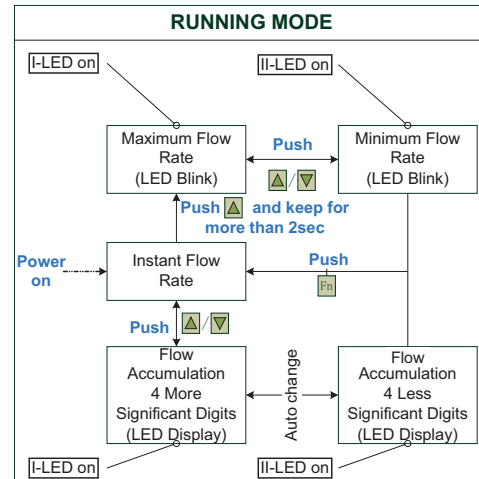

•Instant flow rate mode

1. This is the default display mode, in which the two LED indicators are off.
2. The instant flow rate is displayed by the 4-digit LED panel with one decimal digit available. The flow rate unit is SLPM.
3. When the flow rate exceeds the maximum allowable flow rate, I-LED will blink.
4. When the flow rate exceeds the minimum allowable flow rate, II-LED will blink.

5. When the flow rate exceeds the maximum displayable reading, both I-LED and II-LED will blink simultaneously, which implies that the reading is incorrect (since the reading has been rounded off to fit the display, although the measurement may still be correct).

•**Flow accumulation mode**

1. In this display mode, the two LED indicators are turned on.
2. The flow accumulation is displayed as an 8-digit numeric number in a time-division scheme. When the first LED indicator (I-LED) turns on, the 4-digit LED panel displays the more significant digits of the flow accumulation. After 1 second, the second LED indicator (II-LED) turns on and the 4-digit LED panel displays the less significant digits of the flow accumulation.
3. The flow accumulation unit is SL. The flow accumulation reading can be reset to zero by a key operation.

NOTE: The flow accumulation will be saved every 3 minutes. For instance:

- 1, The flow accumulation will not be saved if power off @ 2 minutes.**
- 2, The flow accumulation will be the value of 33 minutes if power off @ 34 minutes.**

•**Maximum / minimum mode**

1. In this mode, the maximum flow rate and the minimum flow rate (since the last power-on or the last maximum/minimum flow rate resetting) will be displayed.
2. When the maximum flow rate is shown, I-LED will turn on and the 4-digit LED panel will blink.
3. When the minimum flow rate is shown, II-LED will turn on and the 4-digit LED panel will blink.

Menu Setting Mode

Under the menu setting mode, various operations including keyboard lock/unlock, flow accumulation reset, automatic offset calibration, gas selection, response time setting, display refresh setting, maximum/minimum flow rate reset can be performed.

•**Keyboard lock**

1. Prevent unintentional modifications of system parameters.
2. After the keyboard is locked, the user will be unable to perform any other menu settings unless the keyboard is unlocked by the user.

•**Flow accumulation reset**

Reset the flow accumulation reading to 0 SL, and the flow accumulation counts re-starting at 0 SL.

•**Automatic offset calibration**

Perform offset calibration, which is used for resolving the possible offset drifting after certain period of operation.

NOTE: Before performing automatic offset calibration, please ensure that the gas in the pipe is static, i.e., at zero flow. Otherwise, it may cause inaccuracy during the measurement.

MENU SETTING MODE

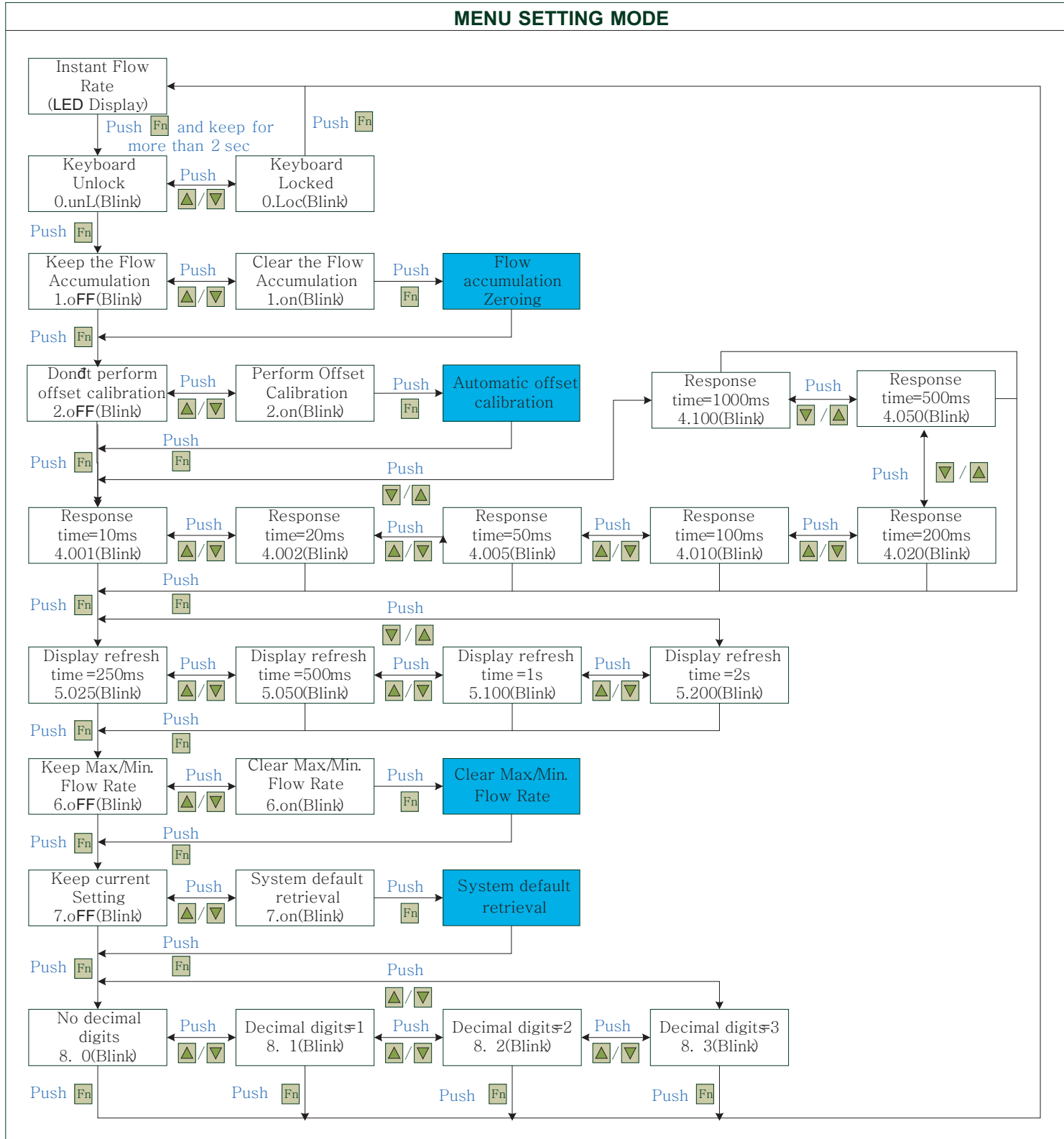

• **Response time setting**

1. Set the response time of the analog output signal;
2. Set the time interval for the digital output signal;
3. After each setting is completed, it is in effect immediately. However, it is stored in the internal EEPROM only when a new menu operation is invoked. If the power is off before a new menu operation is invoked, the setting will be discarded without being stored.

Display	4.001	4.002	4.005	4.010	4.020	4.050	4.100
Response Time	10 ms	20 ms	50 ms	100 ms	200 ms	500 ms	1000 ms

• **Display refresh setting**

1. Set the time interval for the display refresh;
2. After each setting is completed, it is in effect immediately. However, it is stored in the internal EEPROM only when a new menu operation is invoked. If the power is off before a new menu operation is invoked, the setting will be discarded without being stored.

Display	5.025	5.050	5.100	5.200
Refresh Time	250 ms	500 ms	1000 ms	2000 ms

• **Maximum / minimum flow rate record clearing**

1. Reset the maximum/minimum flow rate register, and the maximum/minimum flow rates will be re-starting from the initial state.
2. The maximum/minimum flow rate record will be automatically reset when the meter is power off.

• **System default restore**

Reset all the system parameters to the default values specified in the factory.

• **Decimal setting**

Set the number of decimal digits.

NOTE: The maximum number of decimal digits is depended on the maximum flow rate. For example, when the maximum flow rate is 10,20,30,40,50 L/min, the number of decimal digits can be at most 2, e.g., 49.99 L/min.

Safety and Maintenance

• **Wetted materials and compatibility**

The meter body is made of medical compatible plastics. Sensor comprise of silicon, silicon nitride and silicon dioxide and the sensor surfaces are passivated with silicon nitride and silicon dioxide. The electronic sealing is provided by RTV (room temperature vulcanizing) silicone sealant WR-704 composed of HOCH3 (SiO) nCH3H.

•**Safety precautions**

The product is designed for use with general purpose gases such as air and nitrogen. It is advised that the products are best used for non-explosive clean gases. The sensors cannot be used for gas metrology of fluoride or fluoride containing gases. For updates of the product certification information, please contact manufacturer or visit www.Siargo.com. Use for other gases such as extreme corrosive and toxic may cause the product malfunctioning or even severe damages. The product sealing is ensured to work under working pressure of 0.5 MPa and is leakage proof before the shipment. But cautions and further leakage test are important at installation as well since any leakage could cause severe safety issue. The power supply for this product is 8~24 VDC, all precautions and measures for electrical voltage handling must apply.

Attention: Any alternation and/or improper use of the product without the permission of the manufacturer can cause unpredicted damages and even injuries or other severe situations. Siargo Ltd or any of its employees, subsidiaries shall not be hold and indemnified against such consequences due to such circumstances via improper use of the product.

All maintenance of the meter should be done by trained and certified personnel by Siargo, Ltd. products.

Customer Service and Order

Headquarters

Siargo Ltd.
3100 De La Cruz Boulevard, Suite 210,
Santa Clara, California 95054, USA
Phone: +01(408)969-0368
Email: info@Siargo.com

Representative in Japan

Marubeni Information Systems Co., Ltd.
Device Solutions Department
3-12-18 Shibuya,
Shibuya-ku, Tokyo 150-0002 Japan
Phone: +81-3-5778-8661

Representative in Europe

IDENTIC Stefanie Trojan
In der Siedlerruh 24
69123 Heidelberg / Germany
Phone: +49-(0)6221-7509777
Fax: +49-(0)6221-7509779
Email: info@identic.de

Appendix RS232/RS485 Communication Protocol (Mode B)

• Hardware connection

MF4000 sensor protocol is based on standard Modbus RTU mode. A master (PC or PLC) can communicate with several slaves (MF4000), setting parameter or getting data.

The hardware layer is TIA/EIA-485-A. The connection is as below:

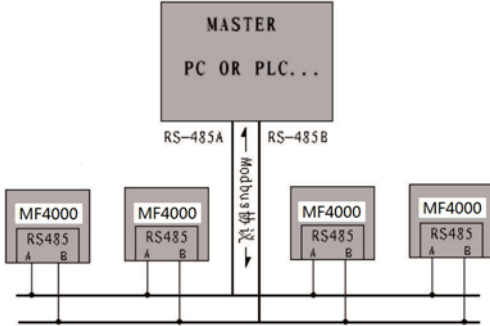

• Communication parameter

The UART parameter is shown as below table:

Communication parameter	protocol
	RTU
Baud rate(Bits per second)	38400 bps
Start bits	1
Data bits	8
Stop bits	1
Even/Odd parity	None
Bits period	104.2 μs
Bytes period	1.1458 ms
Maximum data length	20
Maximum Node	247

• Frame

The framing function is accord with The Standard Modbus RTU framing, which is shown as below:

Start_bits	Address	Function code	Data	CRC	Stop_bits
T1-T2-T3-T4	8Bit	8Bit	N 8Bit (20≥N≥0)	16Bit	T1-T2-T3-T4

Start_bits: 4 periods bit time, to indicate a new frame.

Address: The address, can be set as 1 to 247, 0 is broadcast address.

Function code: Define the action that MF4000 should takes, or indicate that which code the MF4000 is responding.

Data: Including the address of register, length of data and the data.

CRC : CRC verify code, the low byte is flowed by high byte. For example, the 16bit CRC code is divide as BYTE_H BYTE_L, in the frame, the BYTE_L goes first, then the BYTE_H, at last, is the stop signal.

Stop_bits: 4 periods bit time, to indicate that the current framing is over.

• Function code

MF4000 Modbus Function-code is a subclass of Standard Modbus Function-code. By using these function-code, We can set or read the registers of MF4000.

They are shown as below table:

CODE	Name	action
0x03	Read register	Read register (one or more)
0x06	Set single register	Write one single 16bit register
0x10	Set multi registers	Write multi registers

• Registers

MF4000 has several registers. We can get the information (such as “address”, “flow rate” and so on) form reading these registers, or we can write into some of the registers for setting parameters of MF4000.

The registers are shown as below table:

NAME	Description	REGISTER
Communication Protocol	The communicate protocol of MF4000 (W/R)	0x0000
Address	The address of MF4000 (W/R)	0x0001
Flow Rate	The current flow rate (R)	0x0002~0x0003
Total	The accumulative total of flow rate (W/R)	0x0004~0x0006

* R-read only, W/R-write and read.

Communicate Protocol	0x0000	WRITE	A
		READ	A
Description	Protocol mode		
Value type	UINT16		
Detail	Value = 0: Mode A, Siargo communicate mode Value = 1: ModBus mode		
Flow meter Address	0x0001	WRITE	A
		READ	A
Description	The address of MF4000 in modbus protocol		
Value type	UINT16		
Detail	Value from 1 to 255 except 157 (0x9d). 0 is broadcast address.		
Flow Rate	0x0002 ~ 0x0003	WRITE	N
		READ	A
Description	The current flow rate		
Value type	UINT16		
Detail	Flowrate = (value(0x0002) * 65536 + value(0x0003)) / 1000 Example: When we get "0" from register 0x0002 and "20340" from register 0x0003. Flowrate = (0*65536 + 20340)/1000= 20.340		
Total	0x0004 ~ 0x0006	WRITE	A
		READ	A
Description	The accumulative total of flow		
Value type	UINT32 + UINT16		
Detail	V1 = value (0x0004) * 65536 +value (0x0005) V2 = value (0x0006) Total = (V1 * 1000 + V2)/1000 Example: When the LCD shows 3452.245NCM, we can get "0" from register 0x0004, "3452" from register 0x0005, "245" from register 0x0006. Then, V1 = 0*65536 + 3452; V2= 245 Total =(3452*1000+245) /1000=3452.245		