

ATO

USER MANUAL

MSL Series



CONTENTS

1 Principle of Measurement	4
2 Product Structure Diagram	5
3 Product Parameter List	6
4 Pin and Electrical Parameters	8
4.1 Pin Layout	8
4.2 Pin Definition	8
4.3 Voltage Limit Value	9
5 Module Connection	9
5.1 Multi-module Connection	9
5.2 Connector Selection	10
6 Status Code	10
7 Troubleshooting	10
8 Command Reference List	11
9 Operating Protocols	12
9.1 USART Interface	12
10 Control Flow Chart	12
11 Measurement Modes	13
11.1 Single Measurement	13
11.2 Continuous Measurement	13
12 Mode of Work	14
12.1 Automatic Mode	14
12.2 Low Speed Mode	14
12.3 Fast Mode	14
13 Control Command Framework	14
14 Control Register	14
15 Control Command	15
15.1 Read the Laser Module Status	15
15.2 Read the Hardware Version	15
15.3 Read the Software Version	15
15.4 Read the Module Serial Number	16

15.5 Read the Input Voltage	16
15.6 Read the Current Offset	17
15.7 Read the Result of a Measurement	17
15.8 Set the Module Address	18
15.9 Set the Module Offset	19
15.10 Turn On/Off the Laser	19
15.11 Single Automatic Measurement	19
15.12 Single Low Speed Measurement	20
15.13 Single High Speed Measurement	20
15.14 Continuous Automatic Measurement	20
15.15 Continuous Low Speed Measurement	21
15.16 Continuous High Speed Measurement	21
15.17 Error Feedback	21
15.18 Exit Continuous Measurement Mode	21
15.19 Enable Multi-node Measurement	22
16 Quick Test Guide	22
16.1 Preparation Before Testing	22
16.1.1 Prepare the Device	22
16.1.2 Connect the Products	23
16.1.3 Open the Measuring Software	23
16.2 Quick Testing Steps	23
16.2.1 Software Function Area Introduction	23
16.2.2 Button Description	24
16.2.3 Operation Steps	24
16.2.4 Custom command	25
17 Precautions for Use	25

1. Principle of Measurement

At present, the optical time-of-flight measurement methods used in laser ranging mainly include: direct Time of Flight measurement (dToF) and indirect Time of Flight measurement (iToF).

The dToF is a direct measurement of the time difference between transmitting laser and receiving laser, and inverse calculation of the distance of laser travel according to the speed of light. Based on the speed of light, this method requires the circuit related to the measurement of optical time of flight to have a very high reaction speed to improve the resolution of the measurement of time of flight, so as to improve the final ranging distance resolution. In view of the current technical level of the device, its distance division rate can be centimeter.

The iToF usually refers to the method of indirectly measuring the time of flight of light by modulating the emitted laser and analyzing the change of the relevant characteristics of the modulated laser after the propagation of a certain distance. This method is most commonly used for the analysis of the phase characteristics of the modulated laser.

Compared with the dToF, the iToF greatly reduces the requirements for hardware processing speed, is easy to implement and has a higher distance division rate, which can currently reach the millimeter or even micron level. However, due to the need to analyze the modulation information of the laser, the measurement speed of iToF is much lower than that of dToF.

This product uses the iToF is much more precisely, the use of phase difference laser ranging method, which is usually suitable for short and medium range ranging, measuring accuracy up to millimeter or even micron level. The basic principle of the phase difference laser ranging method is to modulate the emitted laser at a specified frequency, and illuminate the modulated laser to the measured object, and then reflect back to the receiver by the measured object. The phase information carried by the transmitted modulated laser and the modulated laser received after reflection will be different, and the phase difference can be calculated by analyzing the phase of the transmitted and the received phase. The actual propagation distance of the laser can be calculated by combining the phase difference information and the specified modulation frequency. Figure 1-1 shows the basic schematic diagram:

The measured distance can be expressed as: $2L = \Delta\varphi \times c \times T / 2\pi$

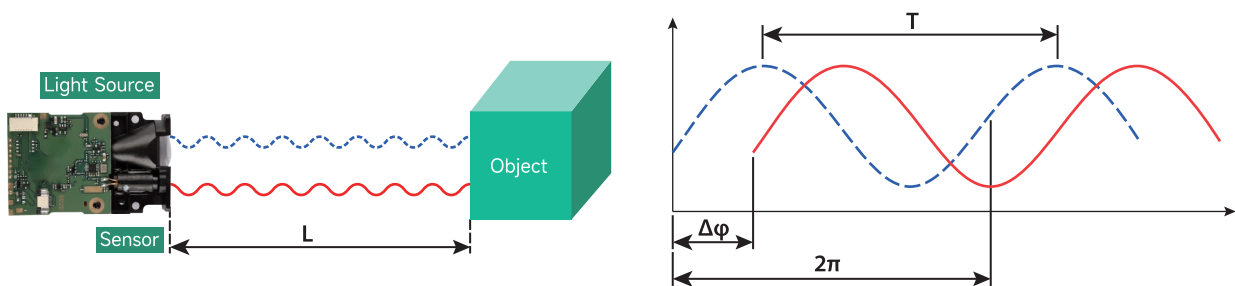

Figure 1-1 Basic Schematic Diagram of Laser Module

In the formula, L represents the measurement distance, c represents the speed of light propagation in the air, and T represents the period of the modulation signal, $\Delta\varphi$ The phase difference between emitting modulated light and receiving modulated light.

Phase based laser ranging has the advantages of high ranging accuracy, wide measurement range, and strong anti-interference ability, and is therefore widely used in industries, surveying, remote sensing, and other fields.

2. Structure Diagram

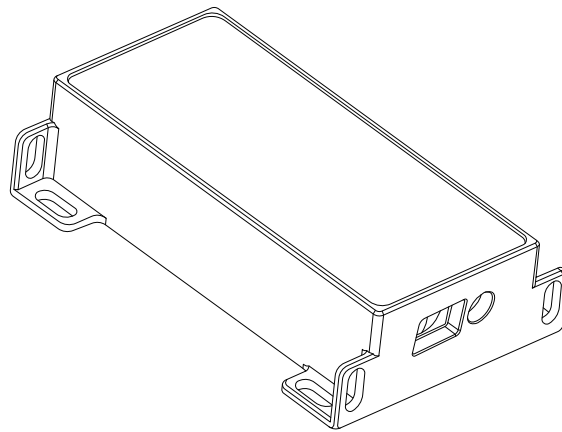

Figure 2-1 Module Overview

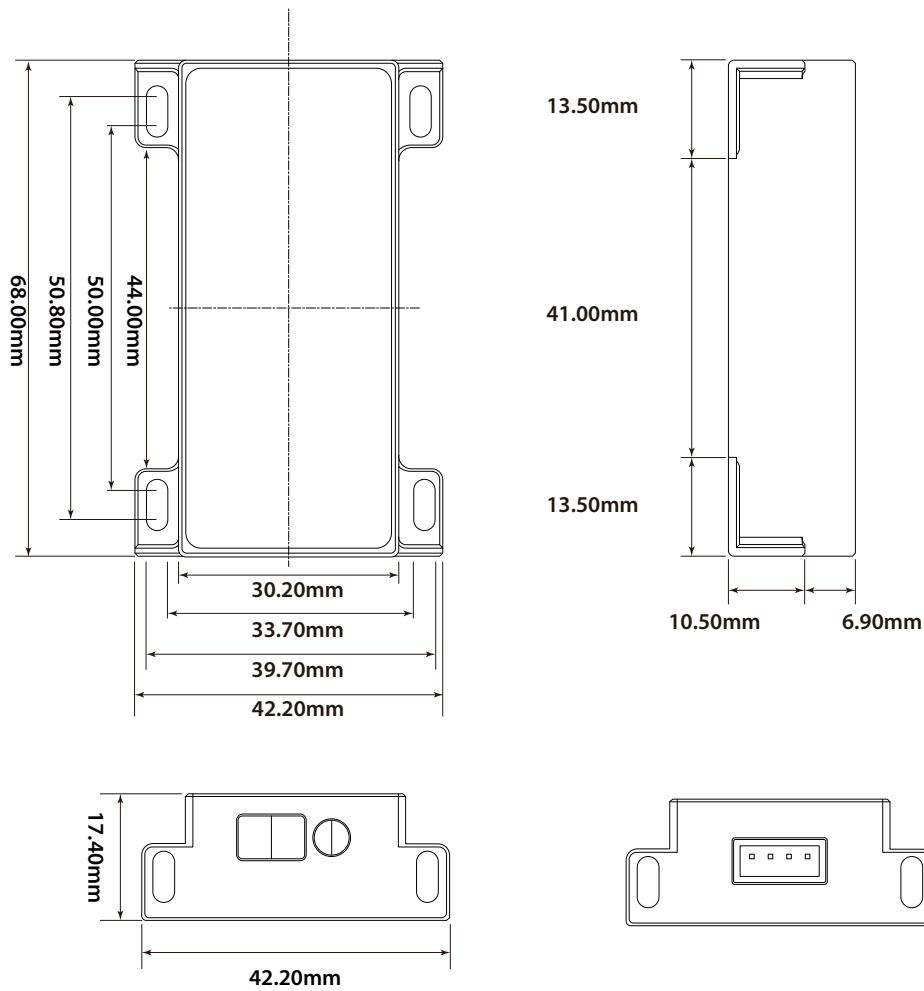

Figure 2-2 Module Structure Dimensional Diagram

3. Product Parameters

Table 3-1 Product Parameters Table

Type	Parameter Name	Parameter Value		
Product Performance	Measurement Range	0.03~40m (Reflectivity: 1.0,interference light intensity: 3kLux)		
	Measurement Unit	mm		
	Measurement Time	0.3~4 seconds (Reflectivity: 1.0, interference light intensity: 1kLux)		
	Accuracy	$\pm(3\text{mm}+D*(1/10000))$ (Reflectivity: 0.2-1.0, interference light intensity: 1kLux)		
	Measurement Resolution	1mm		
	Continuous Measurement Frequency	3Hz/20Hz (Reflectivity: 1.0, interference light intensity: 1kLux, Distance: 0.03m-10m)		
	Reflectivity Range	0.02~1.0		
	Laser Class	CLASS-II, according to IEC 60825-1		
Optical Parameters	Laser Power	<1mW		
	Laser Wavelength	$\lambda=610\text{nm}\sim 690\text{nm}$		
	Laser Spot Diameter	<8mm@10m; <20mm@20m; <40mm@40m		
	Spot Dispersion Range	Spread target circle diameter< 100mm@10m Target		
		Spread target circle diameter< 200mm@20m Target		
		Spread target circle diameter< 300mm@30m Target		
	Power Supply Voltage	RS-485 version	DC:5V-36V;	
		RS-232 version (5V)	DC:5V;	
RS-232 version (5-36V)		DC:5V-36V;		
TTL Version(3.3V)		DC:3.3V;		
TTL Version(5-36V)		DC:5V-36V;		
Electrical Parameters	Current	RS-485 Version	Turn off laser	<30mA@5V
			Turn on laser	<50mA@5V
			Continuous measurement mode	<80mA@5V
		RS-232 Version (5V)	Turn off laser	<30mA@5V
			Turn on laser	<55mA@5V
			Continuous measurement mode	<90mA@5V
		RS-232 Version (5-36V)	Turn off laser	<30mA@5V
			Turn on laser	<50mA@5V
			Continuous measurement mode	<80mA@5V
		TTL Version (3.3V)	Turn off laser	<30mA@3.3V
			Turn on laser	<55mA@3.3V
			Continuous measurement mode	<120mA@3.3V
TTL Version (5-36V)	Turn off laser	<30mA@5V		
	Turn on laser	<50mA@5V		
	Continuous measurement mode	<80mA@5V		
Communication Characteristics	RS-485 version	Maximum 12Mbps (theoretical value)		
	RS-232 version	Maximum 250Kbps (theoretical value)		
	Transmission Rate	TTL Version (3.3V)	Fixed Baud Rate	The default baud rate is 115200bps, customization (4800bps, 9600bps, 19200bps, 38400bps, 115200bps)
			Automatic Baud Rate	The default baud rate is 115200bps, and the baud rate can be set to (9600~115200bps)
	Communication Level	RS-485 version	RS-485	
		RS-232 version	RS-232	
TTL version		TTL (3.3V)		
Other	Dimension	68x42x17.4mm(length×width×height)		
	Weight	52g±1g		
	Working Temperature	0~40°C (32~104°F)		
	Storage Temperature	-25~60°C (-13~140°F)		

- 1) Under poor measurement conditions, the range will decrease and the error will increase, such as strong ambient light, large or small diffuse reflection coefficient of the measured point;
- 2) A wider working temperature range can be customized;
- 3) Higher working frequency can be customized.

The following table is a common table of object reflectivity parameters, which can be used to measure whether the module meets the requirements based on the following parameters

Table 3-2 Material Reflectivity Reference Table

NO.	Material Name	Reflectivity
1	Black velvet	0.5%
2	Black paper	1~2%
3	Dark green leaves	1~10%
4	Pure water	2%
5	Black cloth	3%
6	Asphalt	4%
7	Brown walls	6%
8	Shady sands & rocks	6~10%
9	Quartz glass	8%
10	Black cardboard	10%
11	Mud wall	10%
12	Black paint	10~15%
13	Brown wood	12%
14	Tile	15%
15	Bright green leaves	15~20%
16	Bright sands & rocks	18~24%
17	Clean rough board	20%
18	Red brick	20%
19	Young leaves	20~25%
20	Grey paint	20~30%
21	Grey concrete	25%
22	Cedar board painted with yellow lacquer	40%
23	Cedar board surface (real color)	45%
24	White polyethylene plastic	60%
25	White wall	60%
26	White paint	60%
27	Pure white felt	60~70%
28	White paper	60~75%
29	White enamel	70%
30	The surface of newly fallen snow	70~74%
31	White latex paint	80%
32	Pure white cloth	80~85%
33	Grinding surface of glass	85%
34	Gypsum	87%
35	White cardboard	90%
36	Grinding surface of silver	92%
37	Kodak standard whiteboard	100%

4. Pins and Electrical Parameters

4.1 Pin Layout

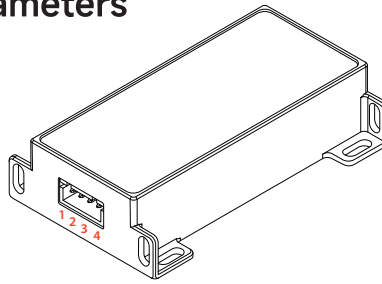

Figure 4-1 Module Pin Layout and Recommended Wiring

4.2 Pin Definition

Table 4-1 Pin Definition with RS485

No.	Name	Function	Default Level	Explanation
1	GND	Ground Wire	Ground wire decision	Module power supply grounding
2	B-	RS-485 Input/Output	High impedance state	RS-485 Device Differential signal (DATA-) Reverse Input/Output
3	A+	RS-485Input/Output	High impedance state	RS-485 Device Differential signal (DATA+) Non-Reverse Input/Output
4	VCC	Power Input	Power decision	Typical module input power requirements:>300mA@DC:5V

Table 4-2 Pin Definition with RS-232 5V

No.	Name	Function	Default Level	Explanation
1	GND	Ground Wire	Ground Wire Decision	Module power supply grounding
2	RXD	RS-232 Level Digital Input	0	Module receiving pin of RS-232
3	TXD	RS-232 Level Digital	Logic 1	Module transmission pin of RS-232
4	VCC	Output	Power Decision	Typical module input power requirements:>300mA@DC:5V

Table 4-3 Pin Definition with RS-232 5-36V

No.	Name	Function	Default Level	Explanation
1	GND	Ground Wire	Ground Wire Decision	Module power supply grounding
2	RXD	RS-232 Level Digital Input	0	Module receiving pin of RS-232
3	TXD	RS-232 Level Digital Output	Logic 1	Module transmission pin of RS-232
4	VCC	Power Input	Power Decision	Typical module input power requirements:>300mA@DC:5V

Table 4-4 Pin Definition with 3.3V TTL

No.	Name	Function	Default Level	Explanation
1	GND	Ground Wire	Ground Wire Decision	Module power supply grounding
2	RXD	TTL Level Digital Input	High	Module Receiving pin of UART
3	TXD	TTL Level Digital Output	High	Module transmission pin of UART
4	VCC	Power Input	Power Decision	Typical module input power requirements: >300mA@DC:3.3V

Table 4-5 Pin Definition with 5-36V TTL

No.	Name	Function	Default Level	Explanation
1	GND	Ground Wire	Ground Wire Decision	Module power supply grounding
2	RXD	TTL Level Digital Input	High	Module receiving pin of UART
3	TXD	TTL level Digital Output	High	Module sending pin of UART
4	VCC	Power Input	Power Decision	Typical module input power requirements: >300mA@DC:5V

4.3 Voltage Limit Value

Table 4-8 Voltage Limit Value with RS-232 (5-36V)

Parameter	Minimum Value	Maximum Value
GND	0	0
RXD	-15V	15V
TXD	-13.2V	13.2V
VCC	-50V	36V

Table 4-7 Voltage Limit Value with RS-232 (5V)

Parameter	Minimum Value	Maximum Value
GND	0	0
RXD	-15V	15V
TXD	-13.2V	13.2V
VCC	-12V	6.0V

Table 4-10 Voltage Limit Value with TTL (5-36V)

Parameter	Minimum Value	Maximum Value
GND	0	0
RXD	-0.3V	5.8V
TXD	-0.3V	5.8V
VCC	-0.3V	36V

Table 4-9 Voltage Limit Value with TTL (3.3V)

Parameter	Minimum Value	Maximum Value
GND	0	0
RXD	-0.3	VCC+0.3V
TXD	-0.3V	VCC+0.3V
VCC	-12V	4V

Table 4-6 Voltage limit Value with RS-485

Parameter	Minimum Value	Maximum Value
GND	0	0
B-	-7V	13V
A+	-7V	13V
VCC	-50V	36V

5. Module Connection

5.1 Multi-module Connection

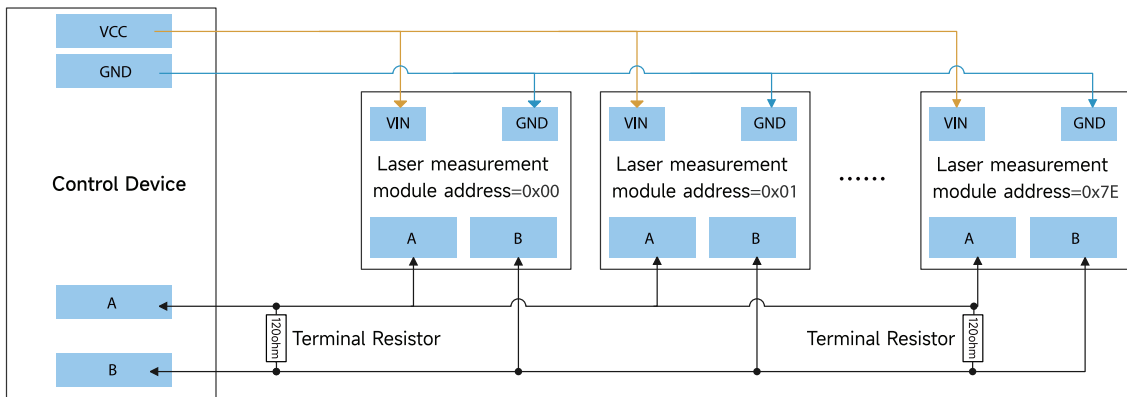

Figure 5-1 Multi-module connection diagram for RS-485 interface

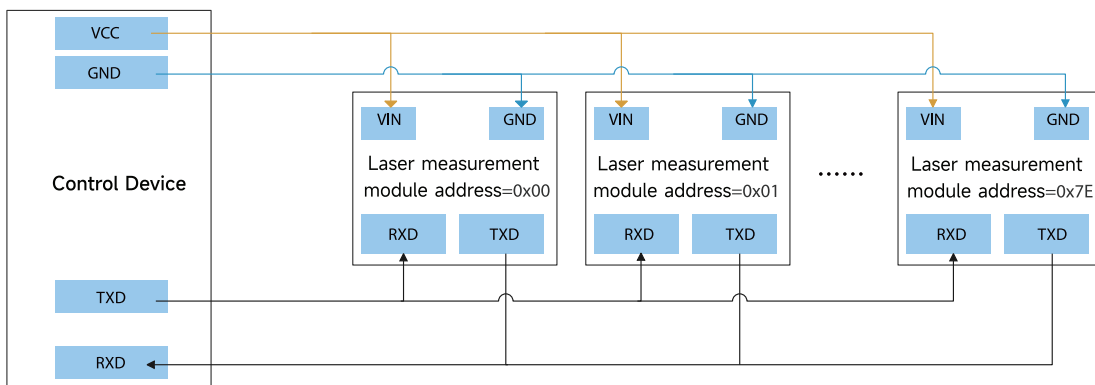

Figure 5-2 Multi-module connection diagram for RS-232 interface

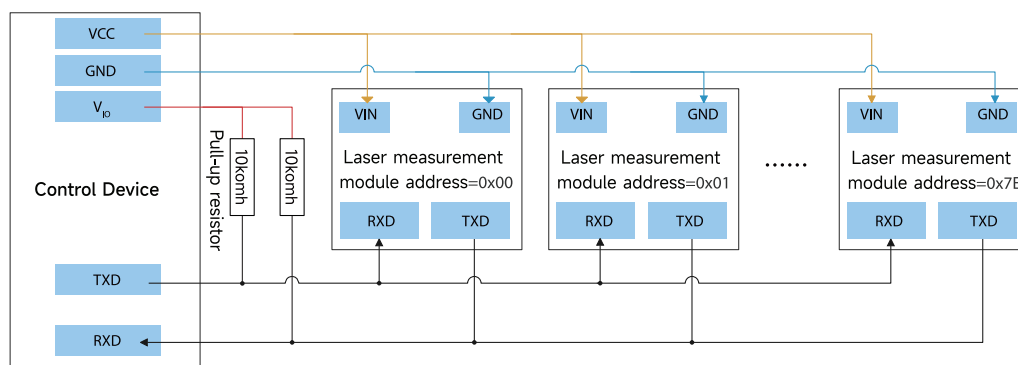

Figure 5-3 Multi-module connection diagram for TTL interface

Note: The number of modules in a single network segment should not exceed 8, and the maximum number of modules within multiple network segments should not surpass 128.

6. Status Code

Table 6-1 Explanation of Module Returning Its status code Information

Status Code	Description	Measures
0x0000	No errors	-
0x0001	The input voltage is low	Check input battery voltage, change battery
0x0002	Network error, can be ignored	-
0x0003	Module temperature is low (<-20°C)	Increase the temperature around the module
0x0004	Module temperature is high (>+55°C)	Reduce the temperature around the module
0x0005	Target out of range	Testing distance in the scope specified in the manual
0x0006	Invalid measurement value	Remeasure
0x0007	Excessive ambient light	Reduce the light intensity of the measurement environment
0x0008	Weak laser signal	Whether there is contamination on the output lens or replace it with a reflective surface with a suitable reflective signal.
0x0009	Strong laser signal	Replace the reflective surface with a suitable reflective signal for testing
0x000A	Hardware error1	Ask customer service based on the error code
0x000F	Laser signal instability	Check if the power supply is stable
0x0081	Invalid communication format	Check if the command was sent incorrectly

7. Fault Handling

1. Measures can be taken: when the computer does not detect the serial port device after connecting with a USB to RS-485 (USB to RS-232/USB to TTL) module.

a. Check whether the computer has installed the driver of the corresponding adapter module. If not, you need to download and install the corresponding driver first;

b. Check whether the communication interface connection between the USB to RS-485 (USB to RS-232/USB to TTL) module and the computer is stable;

c. Check if the computer USB port is damaged or if the USB to RS-485 (USB to RS-232/USB to TTL) module is damaged;

2. Measures can be taken: when the module is successfully powered on and connected to the computer, but there is no response when sending commands to the module.

a. For RS-485 version, check whether the pin of the module A+ and B- are connected inversely. For RS-232 and TTL serial port version, check whether the pin of the module TXD and RXD are connected inversely.;

b. Check whether the baud rate is set correctly;

3. The module can communicate normally, but the received data displays garbled characters:
 - a. Check whether the Serial Port Utility is set to HEX display (hexadecimal display);
 - b. Checking communication stability:
 1. Check whether there is electromagnetic interference or other signal interference nearby. If so, try to stay away from it.
 2. Whether the serial communication cable is too long?
 - If it is ordinary RS-232 (RS-485) communication, the cable should not exceed 10 meters.
 - If it is ordinary USART (TTL level) communication, the cable should not exceed 1 meter.

8. Instruction Reference List

Table 8-1 The Description of the Module Instruction

Function	Sending Instructions/Receiving Data	Explanation
Check Module Status	TX:AA 80 00 00 80	Read the current status of the module
	RX:AA 80 00 00 00 01 00 00 81	Read there is no error in the module
Check Module Hardware Version	TX:AA 80 00 0A 8A	Read the current hardware version of the module
	RX:AA 80 00 0A 00 01 DB 2B 91	Read the current hardware version as 0xDB2B
Check Module Software Version	TX:AA 80 00 0C 8C	Read the current hardware version as
	RX:AA 80 00 0C 00 01 D2 15 74	Read the current software version as 0xD215
Check Module Serial Number Version	TX:AA 80 00 0E 8E	Read the current serial number version of the module
	RX:AA 80 00 0E 00 02 F0 C8 AE 96 8C	Read the current module serial number version as 0xF0C8AE96
Check Module Input Voltage	TX:AA 80 00 06 86	Read the current input voltage of the module
	RX:AA 80 00 06 00 01 32 19 52	Read the current module input voltage as 3219mV
Read the Result of the Last Measurement	TX:AA 80 00 22 A2	Read the result of the last measurement
	RX:AA 80 00 22 00 03 00 00 00 32 00 2C 03	Read the last measurement result of the current module as 0x00000032(50mm)
Set Module Address	TX:AA 00 00 10 00 01 00 05 16	Set module address (change the module address from 0x00 to (0x05)
	RX:AA 00 00 10 00 01 00 05 16	Successfully set module address to 0x05
Set Module Offset	TX:AA 00 00 12 00 01 00 79 8C	Set the module offset to 0x79(121mm)
	RX:AA 00 00 12 00 01 00 79 8C	Offset set successfully
Module On/Off Laser	TX:AA 00 01 BE 00 01 00 01 C1	Turn on laser
	RX:AA 00 01 BE 00 01 00 01 C1	Laser is on
	TX:AA 00 01 BE 00 01 00 00 C0	Turn off laser
	RX:AA 00 01 BE 00 01 00 00 C0	Laser is off
Single Automatic Measurement	TX:AA 00 00 20 00 01 00 00 21	Enable single automatic measurement
	RX:AA 00 00 22 00 03 00 00 00 33 00 2F 87	Return measurement data as 0x00000033(51mm), The signal quality is 0x002F
Single Low-Speed Measurement	TX:AA 00 00 20 00 01 00 01 22	Enable single low-speed measurement
	RX:AA 00 00 22 00 03 00 00 00 32 00 31 88	Return measurement data as 0x00000032(50mm), The signal quality is 0x0031
Single High-Speed Measurement	TX:AA 00 00 20 00 01 00 02 23	Enable single high-speed measurement
	RX:AA 00 00 22 00 03 00 00 00 32 00 33 8A	Return measurement data as 0x00000032(50mm), The signal quality is 0x0033

Continuous Automatic Measurement	TX:AA 00 00 20 00 01 00 04 25	Enable continuous automatic measurement
	RX:AA 00 00 22 00 03 00 00 00 33 00 3C 94	Return measurement data as 0x00000033(51mm), The signal quality is 0x003C
Continuous Low-Speed Measurement	TX:AA 00 00 20 00 01 00 05 26	Enable continuous low-speed measurement
	RX:AA 00 00 22 00 03 00 00 00 33 00 3C 94	Return measurement data as 0x00000033(51mm), The signal quality is 0x003C
Continuous High-Speed Measurement	TX:AA 00 00 20 00 01 00 06 27	Enable continuous high-speed measurement
	RX:AA 00 00 22 00 03 00 00 00 32 00 38 8F	Return measurement data as 0x00000032(50mm), The signal quality is 0x0038

9. Operation Protocol

9.1 RS485/RS232/USART Interface

Module supporting automatic baud rate detection: 9600bps,19200bps,38400bps,115200bps;

Fixed baud rate module: 115200bps,customizable(4800bps、9600bps、19200bps、38400bps、115200bps);

- Start bit: 1 bit
- Data bits: 8 bits
- Stop bit: 1 bit
- Parity bit: None
- Serial port flow control: None

For modules that support Automatic baud rate, if the module does not receive the Automatic baud rate handshake byte 0x 55 or receives the wrong handshake byte within 2.5 seconds after power-up, the module will communicate at a fixed 115200bps.

10. Control Flowchart

All communication commands are sent by the host, and the laser ranging module as a guest to respond to the host's commands. The commands timeline is shown in Figure 10-1:

Module with automatic baud rate:

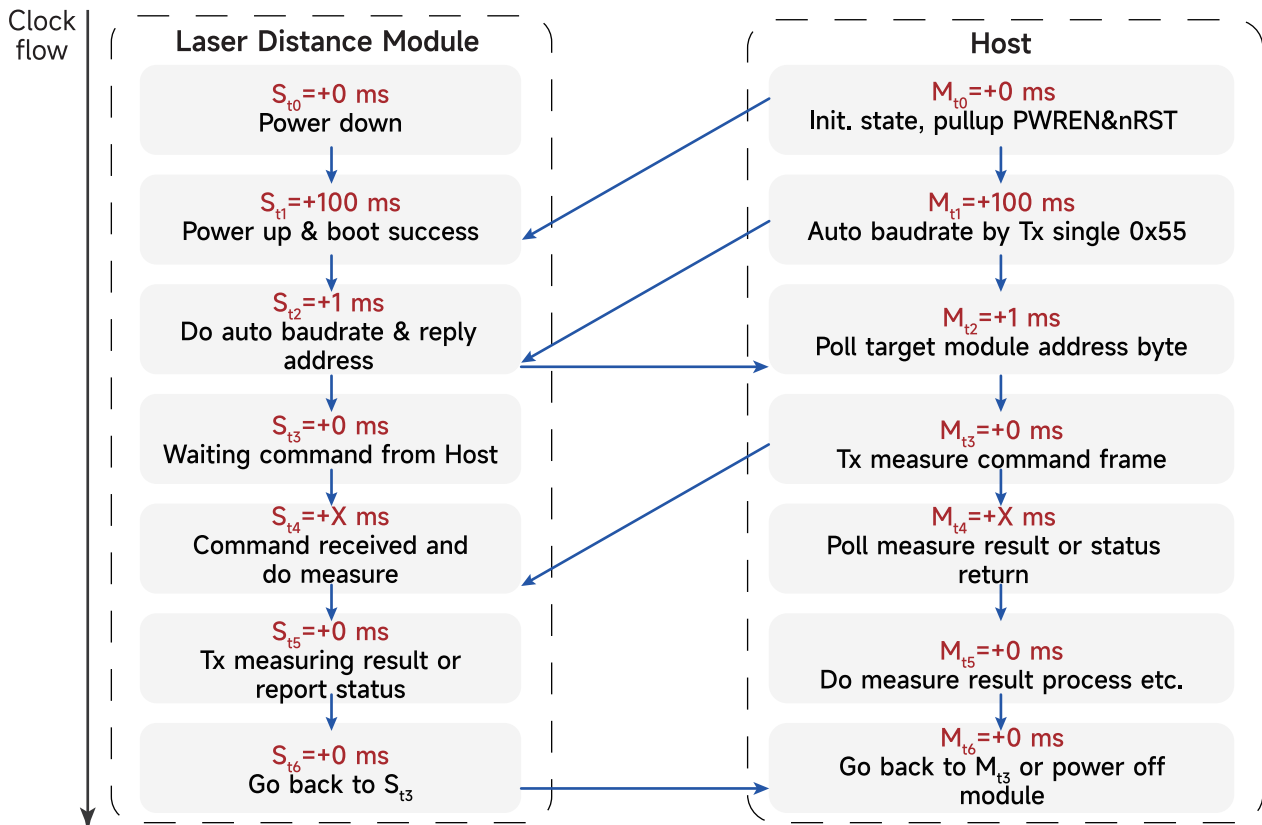

Module with fixed baud rate:

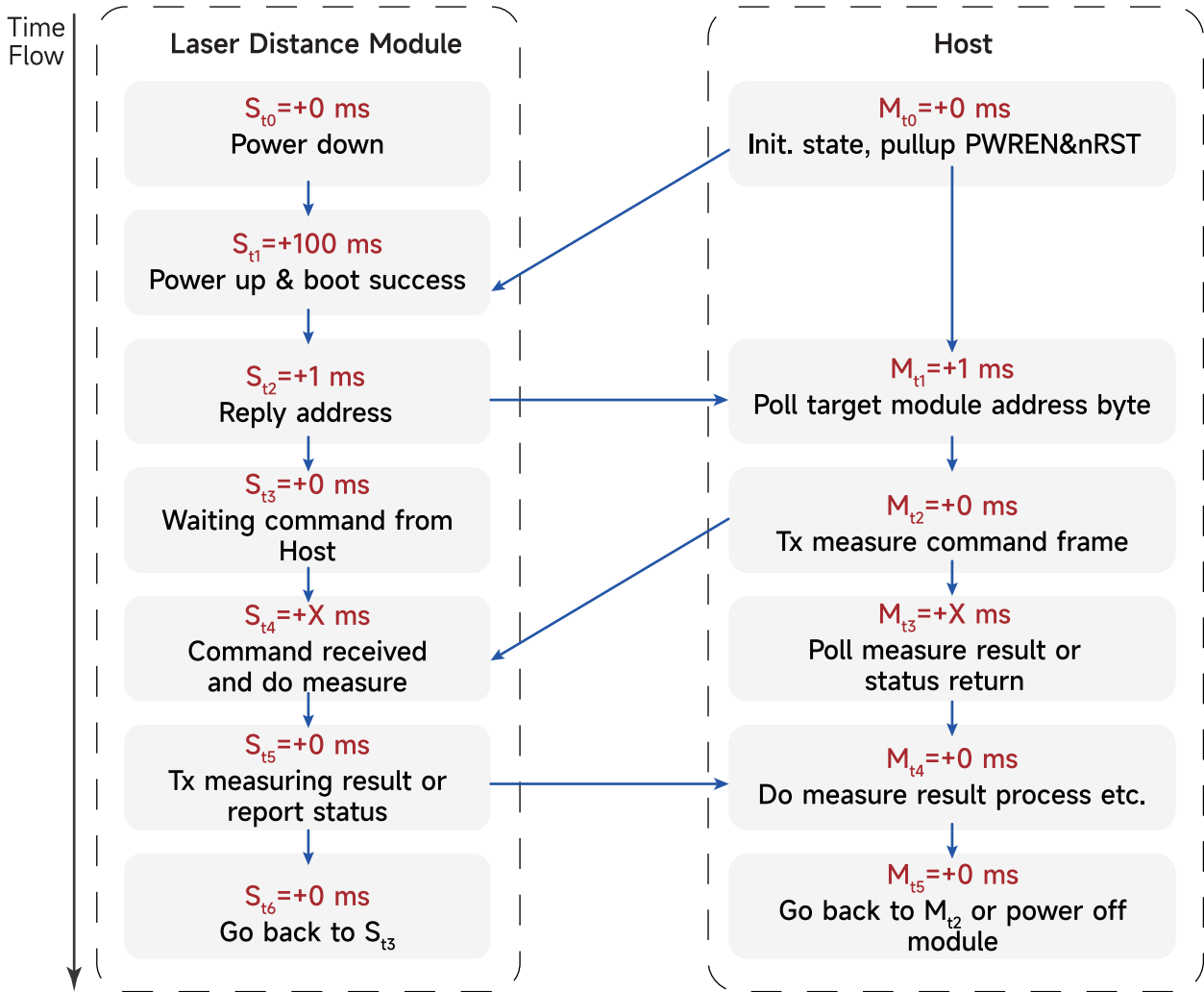

Figure 10-1 Module Communication Timeline

In initial conditions, after the slave device is powered on, if it supports auto-baud rate detection, it will enter the auto-baud rate handshake phase following about 100ms of self-check. In this time, the master device should send the handshake byte (0x55) to slave device. If communication is successful, slave device will reply with a 1-byte data packet which is also the communication address for the slave. In a multi-slave system configuration, when the master send the handshake byte, it will receive address responses from multiple slaves simultaneously. Under this condition, it may causing bus collisions, and the received data should be disregarded.

Once the auto-baud rate is successfully configured, a stable communication link between the master and slave devices will be established.

11. Measurement Mode

11.1 Single Measurement

Send a single measurement command and return a measurement result after successful measurement.

11.2 Continuous Measurement

Send a continuous measurement command, and the module remains in continuous measurement mode. For each successful measurement, the measurement result will be returned. To exit continuous measurement, the host needs to send 1 byte of 0x58 (Capital 'X' in ASCII) during the measurement period.

12. Working Mode

- a. Automatic mode: The module automatically selects the measurement speed based on the reflected signal strength or signal quality. The smaller the signal quality (SQ) value, the more reliable the measurement result, or the higher the signal strength, the more reliable the measurement result.
- b. Low speed mode: prioritized module measurement accuracy
- c. High speed mode: prioritizes module measurement speed

Table 12-1 Mode Function Diagram for Combining Measurement Mode and Working Mode

Working Mode Measurement Mode	Automation Mode	Low Speed Mode	High Speed Mode
Single Mode	Automatic single measurement mode	Low speed single measurement mode	High speed single measurement mode
Continuous Mode	Automatic continuous measurement mode	Low speed continuous measurement mode	High speed continuous measurement mode
Measuring Speed	Medium speed	Low speed	High speed
Measurement Accuracy	Standard accuracy	High accuracy	Low accuracy

13. Control Command Framework

By sending different commands through the computer, the corresponding functions of the module can be used or the corresponding status information of the module can be obtained.

Table 13-1 Communication Format Description

Head	RW	Address	Register	Payload Count	Payload	Checksum
8 bits	1 bit	7 bits	16 bits	16 bits	Data length*16 bits	8 bits
Header	Read and write direction indicator bit	Current guest address	Register address	Register address	Valid data	Checksum
Byte[0]	Byte[1]		Byte[2:3]	Byte[4:5]	Byte[6:N]	Byte[N+1]
Checksum= (byte[1]+byte[2]+byte[3]+...+byte[N])&0xFF						
R/W (Read and write direction indicator bit): Host writes guest data--0; Host reads guest data--1						
Address (address bit): the address has only 7 bits, and range is: 0x00~0x7F. 0x00 is the default factory address of the guest; 0x7F is a broadcast address from one host to multiple guests						

14. Control Register

There are many registers inside the module, and users can perform basic operations on the module by controlling the module registers.

Table 14-1 Summary and Description of Module Control Registers

No.	Register	Name	Effect
1	0X0000	REG_ERR_CODE	System status code
2	0X0006	REG_BAT_VLTG	Input voltage
3	0X0010	REG_ADDRESS	Module address
4	0X0012	REG_OFFSET	Measurement result offset
5	0X0020	REG_MEA_START	Initial measurement
6	0X0022	REG_MEA_RESULT	Measurement result
7	0X01BE	REG_CTRL_LD	Laser diode control

15. Control Command

The following tables provide a detailed description and summary of the commands for the control module.

15.1 Read the Status of the Laser Module

The module status code is used to indicate whether the module currently has software or hardware issues, and users can get the status code of issue through this command, if there is no issue, the status code is 0x0000.

Byte	0	1	2	3	4
Name	First byte	Read and write direction indicator bit / Current guest address	Register address		Checksum
Data	0xAA	0x80	0x00	0x00	0x80

- Command type: read command
- Guest address: 0x00
- Register address: 0x0000
- Command description: after the previous command is executed, the host sends this command to read the current status code of the module
- Guest feedback:

Byte	0	1	2	3	4	5	6	7	8
Name	First byte	Read and write direction indicator bit/Current guest address	Register address		Number of valid data		Valid data		Checksum
Data	0xAA	0x80	0x00	0x00	0x00	0x01	0xYY	0xZZ	Checksum

- Module status: 0xYYZZ

15.2 Read the Hardware Version

Byte	0	1	2	3	4
Name	First byte	Read and write direction indicator bit / Current guest address	Register address		Checksum
Data	0xAA	0x80	0x00	0x0A	0x8A

- Command type: read command
- Guest address: 0x00
- Register address: 0x000A
- Command description: after the previous command is executed, the host sends this command to read the hardware version of the module
- Guest feedback:

Byte	0	1	2	3	4	5	6	7	8
Name	First byte	Read/write direction indicator bit/current guest address	Register address		Number of valid data		Valid data		Checksum
Data	0xAA	0x80	0x00	0x0A	0x00	0x01	0xVV	0xYY	Checksum

- Hardware version number: 0xVVYY

15.3 Read the Software Version

Byte	0	1	2	3	4
Name	First byte	Read and write direction indicator bit/Current guest address	Register address		Checksum
Data	0xAA	0x80	0x00	0x0C	0x8C

- Type: read command
- Guest address: 0x00
- Register address: 0x000C
- Command description: after the previous command is executed, the host sends this command to read the software version of the module
- Guest feedback:

Byte	0	1	2	3	4	5	6	7	8
Name	First byte	Read and write direction indicator bit/Current guest address	Register address		Number of valid data		Valid data		Checksum
Data	0xAA	0x80	0x00	0x0C	0x00	0x01	0xVV	0xYY	Checksum

- Software version: 0xVVYY

15.4 Read the Module Serial Number

Byte	0	1	2	3	4
Name	First byte	Read and write direction indicator bit / Current guest address	Register address		Checksum
Data	0xAA	0x80	0x00	0x0E	0x8E

- Type: read command
- Guest address: 0x00
- Register address: 0x000E
- Command description: after the previous command is executed, the host sends this command to read the module serial number
- Guest feedback:

Byte	0	1	2	3	4	5	6	7	8
Name	First byte	Read and write direction indicator bit/Current guest address	Register address		Number of valid data		Valid data		Checksum
Data	0xAA	0x80	0x00	0x0E	0x00	0x01	0xSS	0xNN	Checksum

- Module serial number: 0xSSNN

15.5 Read the Input Voltage

Byte	0	1	2	3	4
Name	First byte	Read and write direction indicator bit / Current guest address	Register address		Checksum
Data	0xAA	0x80	0x00	0x06	0x86

- Type: read command
- Guest address: 0x00
- Register address: 0x0006
- Command description: after the previous command is executed, the host reads the module input voltage (mV) in BCD format
- Guest feedback:

Byte	0	1	2	3	4	5	6	7	8
Name	First byte	Read and write direction indicator bit/Current guest address	Register address		Number of valid data		Valid data		Checksum
Data	0xAA	0x80	0x00	0x06	0x00	0x01	0x32	0x19	Checksum

- Input voltage: 3219 mV

15.6 Read the Current Offset

Byte	0	1	2	3	4
Name	First byte	Read & Write direction indicator bit / Current guest address	Register address		Checksum
Data	0xAA	0x80	0x00	0x12	0x92

- Type: Read Command
- Guest address: 0x00
- Register address: 0x0012
- Command Description: After the previous command is executed, the host reads the measurement results.
- Guest Feedback:

Byte	0	1	2	3	4	5	6	7	8
Name	First byte	Read & Write direction indicator bit / Current guest address	Register address		Number of valid data		Valid data		Checksum
Data	0xAA	0x00	0x00	0x12	0x00	0x01	0xVV	0xYY	Checksum

- Module offset: 0xV V V Y Y

15.7 Read the Measurement Results

Byte	0	1	2	3	4
Name	First byte	Read/write direction indicator bit/current guest address	Register address		Checksum
Data	0xAA	0x80	0x00	0x22	0xA2

- Type: Read Command
- Guest Address: 0x00
- Register Address: 0x0022
- Command Description: After the previous command is executed, the host reads the offset result.
- Guest Feedback:

Byte	0	1	2	3	4	5	6:9	10:11	12
Name	First byte	Read & Write direction indicator bit / Current guest address	Register address		Number of valid data		Valid data	Signal Quality	Checksum
Data	0xAA	0x00	0x00	0x22	0x00	0x03	0xAABBCCDD	0x0101	Checksum

15.8 Set the Module Address

Byte	0	1	2	3	4	5	6	7	8
Name	First byte	Read & Write direction indicator bit / Current guest address	Register address		Number of valid data		Valid data		Checksum
Data	0xAA	0x00	0x00	0x10	0x00	0x01	0x00	0xYY	Checksum

- Type: Write Command
- Guest Address: 0x00
- Register Address: 0x0010
- Command Description: After the previous command is executed, the host sets the guest address which is then saved in case of a power cut.
- Guest Feedback:

Byte	0	1	2	3	4	5	6	7	8
Name	First byte	Read & Write direction indicator bit / Current guest address	Register address		Number of valid data		Valid data		Checksum
Data	0xAA	0x00	0x00	0x10	0x00	0x01	0x00	0xYY	Checksum

Set the guest address to 0xYY (The address will only take bits [6:0], other bits will be ignored);

Note: Do not set the guest address to broadcast address 0x7F, which is reserved for one host to multiple guest networks. It requires all guests to measure the distance simultaneously and will not be measured until the host requires one guest to measure.

15.9 Setting the Module Offset

Byte	0	1	2	3	4	5	6	7	8
Name	First byte	Read & Write direction indicator bit / Current guest address	Register address		Number of valid data		Valid data		Checksum
Data	0xAA	0x00	0x00	0x12	0x00	0x01	0xZZ	0xYY	Checksum

- Type: Write Command
- Guest address: 0x00
- Register address: 0x0012
- Command Description: After the previous command is executed, the host sets the guest offset, which represents the current ranging starting point and defaults to 0.
For example, if the offset 0xZZYY=0x007B (+123), the final measured value will be increased by 123mm; If the offset 0xZZYY=0xFF85 (-123), the final measured value will be subtracted by 123mm.
- Guest feedback:

Byte	0	1	2	3	4	5	6	7	8
Name	First byte	Read & Write direction indicator bit / Current guest address	Register address		Number of valid data		Valid data		Checksum
Data	0xAA	0x00	0x00	0x12	0x00	0x01	0xZZ	0xYY	Checksum

15.10 Turn On/Off the Laser

Byte	0	1	2	3	4	5	6	7	8
Name	First byte	Read & Write direction indicator bit / Current guest address	Register address		Number of valid data		Valid data		Checksum
Data	0xAA	0x00	0x01	0xBE	0x00	0x01	0x00	0xZZ	Checksum

- Type: Write Command
- Guest Address: 0x00
- Register Address: 0x01BE
- Command Description: After the previous command is executed, turn on/off the laser.
Laser On: 0xZZ=0x01 / Laser Off: 0xZZ=0x00
- Guest Feedback:

Byte	0	1	2	3	4	5	6	7	8
Name	First byte	Read & Write direction indicator bit / Current guest address	Register address		Number of valid data		Valid data		Checksum
Data	0xAA	0x00	0x01	0xBE	0x00	0x01	0x00	0xZZ	Checksum

15.11 Single Automatic Measurement

Byte	0	1	2	3	4	5	6	7	8
Name	First byte	Read & Write direction indicator bit / Current guest address	Register address		Number of valid data		Valid data		Checksum
Data	0xAA	0x00	0x00	0x20	0x00	0x01	0x00	0x00	0x21

- Type: Write Command
- Guest Address: 0x00
- Register Address: 0x0020
- Command Description: after the previous command is executed, the guest will be defined as the single measurement in automatic mode, and the laser will be turned off after one measurement.
- Guest Feedback:

Byte	0	1	2	3	4	5	6:9	10:11	12
Name	First byte	Read & Write direction indicator bit / Current guest address	Register address		Number of valid data		Valid data	Signal quality	Checksum
Data	0xAA	0x00	0x00	0x22	0x00	0x03	0xAABBCCDD	0x0101	Checksum

- Guest return
- Guest address: 0x00
- Register address: 0x0022
- Function: Return the measurement result to the host.
Measurement Result=0xAABBCCDD millimeters (byte 6=0xAA, byte 7=0xBB, byte 8=0xCC, byte 9=0xDD).
- Signal Quality=0x0101, The smaller the signal quality value, the stronger the laser signal and the more reliable the measurement results.

15.12 Low Speed Single Measurement

Byte	0	1	2	3	4	5	6	7	8
Name	First byte	Read & Write direction indicator bit / Current guest address	Register address		Number of valid data		Valid data		Checksum
Data	0xAA	0x00	0x00	0x20	0x00	0x01	0x00	0x01	0x22

- Type: Write Command
- Guest Address: 0x00
- Register Address: 0x0020
- Command Description: After the previous command is executed, the guest will be defined as the low-speed single measurement mode. The measurement result is more accurate with the low-speed mode.
- Guest Feedback: Consistent with the single automatic measurement feedback command.

15.13 High Speed Single Measurement

Byte	0	1	2	3	4	5	6	7	8
Name	First byte	Read & Write direction indicator bit / Current guest address	Register address		Number of valid data		Valid data		Checksum
Data	0xAA	0x00	0x00	0x20	0x00	0x01	0x00	0x02	0x23

- Type: Write Command
- Guest Address: 0x00
- Register Address: 0x0020
- Command Description: After the previous command is executed, the guest will be defined as the high-speed single measurement mode. The measurement result is less accurate than the low-speed measurement mode.
- Guest Feedback: Consistent with the single automatic measurement feedback command.

15.14 Continuous Automatic Measurement

Byte	0	1	2	3	4	5	6	7	8
Name	First byte	Read & Write direction indicator bit / Current guest address	Register address		Number of valid data		Valid data		Checksum
Data	0xAA	0x00	0x00	0x20	0x00	0x01	0x00	0x04	0x25

- Type: Write Command
- Guest Address: 0x00
- Register Address: 0x0020
- Command Description: After the previous command is executed, the guest will be defined as the continuous measurement in automatic mode. After sending the command, the module will continuously measure the distance at a fixed frequency.
- Guest Feedback: Consistent with the single automatic measurement feedback command.

15.15 Low Speed Continuous Measurement

Byte	0	1	2	3	4	5	6	7	8
Name	First byte	Read/write direction indicator bit/current guest address	Register address		Number of valid data		Valid data		Checksum
Data	0xAA	0x00	0x00	0x20	0x00	0x01	0x00	0x05	0x26

- Type: Write Command
- Guest Address: 0x00
- Register Address: 0x0020
- Command Description: After the previous command is executed, the guest will be defined as the continuous measurement in low-speed mode.
- Guest Feedback: Consistent with the single automatic measurement feedback command.

15.16 High Speed Continuous Measurement

Byte	0	1	2	3	4	5	6	7	8
Name	First byte	Read/write direction indicator bit/current guest address	Register address		Number of valid data		Valid data		Checksum
Data	0xAA	0x00	0x00	0x20	0x00	0x01	0x00	0x06	0x27

- Type: Write Command
- Guest Address: 0x00
- Register Address: 0x0020
- Command Description: After the previous command is executed, the guest will be defined as the continuous measurement in high-speed mode.
- Guest Feedback: Consistent with the single automatic measurement feedback command.

15.17 Error Feedback

Byte	0	1	2	3	4	5	6	7	8
Name	First byte	Read/write direction indicator bit/current guest address	Register address		Number of valid data		Valid data		Checksum
Data	0xEE	0x00	0x00	0x00	0x00	0x01	0x00	0x0F	0x10

- Type: Guest feedback
- Guest Address: 0x00
- Register Address: 0x0000
- Command Description: Feedback error status code to the host. Error status code=0x000F. For specific error codes, please refer to 6.1 Status Code.

15.18 Exit Continuous Measurement Mode

The host transfers 1-byte 0x58 (Capital 'X' in ASCII) to stop the continuous measurement mode immediately.

15.19 Enable Multi-node Measurement

The host sends a measurement command to the guest address 0x7F, which will make all online guests to measure the distance simultaneously, the results will not be returned until the host requests the guests to return measurements. Before sending a command to read the measurement results, the host should read the guests' status code to ensure no errors will occur when the guests are working.

Byte	0	1	2	3	4	5	6	7	8
Name	First byte	Read/write direction indicator bit/current guest address	Register address		Number of valid data		Valid data		Checksum
Data	0xAA	0x7F	0x00	0x20	0x00	0x01	0x00	0x00	0xA0

- Type: Write Command
- Guest Address: 0x00
- Register Address: 0x0020
- Command Description: After the previous command is executed, define all guests to be in single automatic measurement mode.
- Guest Feedback: NONE

After sending the command, the host polls the status of all guests; If the status code provided by the guest is 0x0000, indicating no errors, a command to read the measurement results can be sent to read the distance; All guests will not rewrite the previous measurement result until they have successfully received the measurement command and measured a new distance value.

16. Quick Testing Guidance

16.1 Preparation Before Testing

16.1.1 Prepare the device shown below

RS-485 version, Prepare the device shown below

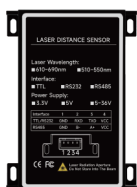

Module



Serial Port Converter



4P*H2.54mm
Terminal Wire



PC



MesController
Software

RS-232 version, Prepare the device shown below



Module



Serial Port Converter



4P*H2.54mm
Terminal Wire



PC



MesController
Software

TTL version, Prepare the device shown below



Module



Serial Port Converter



4P*H2.54mm
Terminal Wire



PC

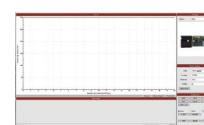

MesController
Software

16.1.2 Connect the Module

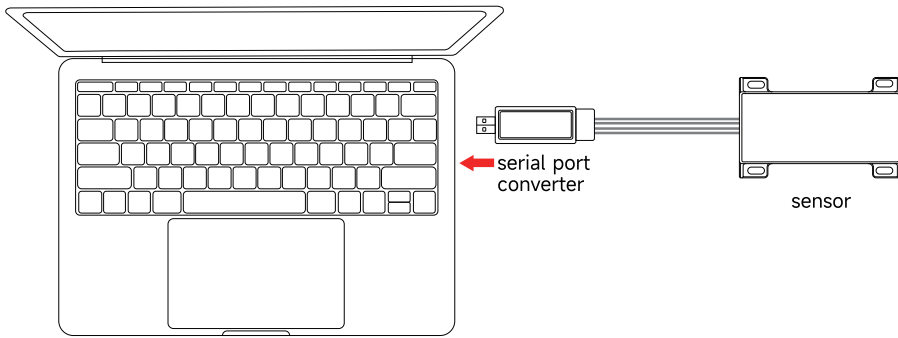

RS-232 Version Connection Diagram

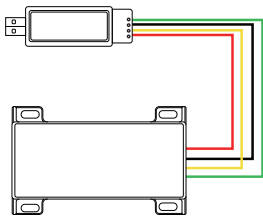

RS-485 Version Connection Diagram

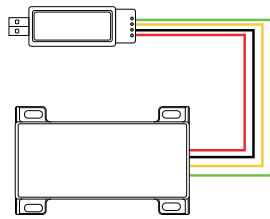

3.3V TTL Version Connection Diagram

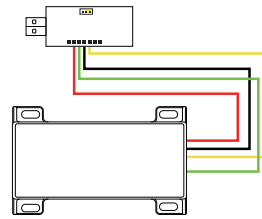

5-36V TTL Version Connection Diagram

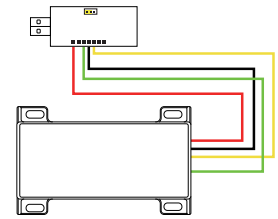

16.1.3 Run the Testing Software

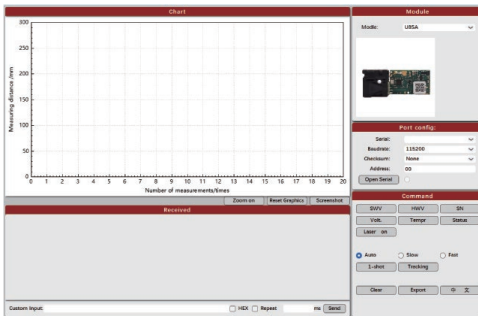

16.2 Quick Testing Steps

16.2.1 Software Function Area Introduction

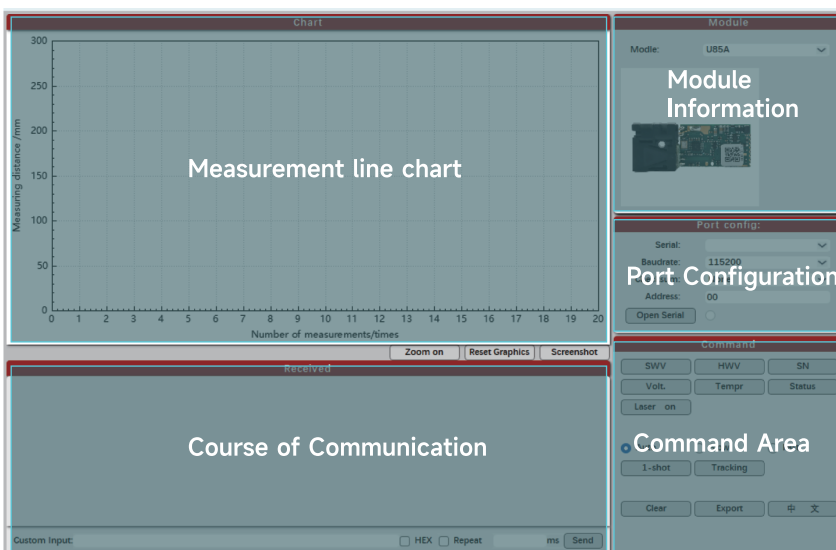

16.2.2 Button Description

Chart:

- Zoom On: Zoom in/out of the line chart to check a certain measurement result
- Reset Graphics: Line Chart Clearing
- Screenshot: Screen shot the current measurement line chart

Port Config:

- Open Serial: Click it can open the module

Command:

- SWV: Module Software Version
- HWV: Module Hardware Version
- SN: Serial Number of the module
- Volt.: Input Voltage for the Module.
- Tempr: Current Temperature for the module
- Status: Read Module's Status
- Laser On: Open the Laser Light
- Auto: Automatic measurement (the frequency variable according to laser signal)
- Slow: Slow measurement (1 measurement per 2 seconds)
- Fast: Fast measurement (4 measurement per 1 second)
- 1-Short: Single Time Measurement
- Tracking: Repeat Measurement
- Clear: Clear Data
- Export: Data Export

16.2.3 Operation Steps

Steps:

- step 0. select UI language;
- step 1. select Modle;
- step 2. select/config COM port linked to laser range find module;
- step 3. Open COM port;
- step 4. Click SWV to show firmware verison if module is connected;
- step 5. Click to turn on laser beam;
- step 6. Choose measuring mode;
- step 7. Start measure;
- step 8. Export measure logs.

Chart: Measuring distance /mm vs Number of measurements /times

Module: Mode: U85A

Port config: Serial: COM1 Port, Baudrate: 115200, Checksum: None, Address: 00

Command: SWV, HWV, SN, Volt., Tempr, Status, Laser on, Auto, Slow, Fast, 1-shot, Tracking, Clear, Export, 中文

16.2.4 Custom Command

- Enter valid commands in the input box for custom command.
- Tick“HEX”to send hex data.
- Tick ‘Repeat’to Input desired time intervals to send data periodically.
- To Input 58 in the Custom command line, tick “Hex” and click “Send ” to exist custom command measurement

17. Precautions for Use

- (1) Please do not look directly at the laser beams
- (2) Please strictly follow the recommended electrical parameters when using the product.
- (3) Please ensure power supply has been cut off before wiring
- (4) Please strictly follow instructions when wiring
- (5) Please keep the front end of the optical lens clean to ensure normal use