

**User's Manual of  
Temperature Input  
Signal Isolator**



**Version**  
U-YDT603S-ZXEN1

**1. Performance Introduction**

Input thermocouple/thermal resistance signal, and output current/voltage signal transmitted via isolation.

The input, output and power supply terminals are isolated from each other. The product provided with online failure self-diagnosis and other functions is a smart temperature transmitter. The dedicated portable programmer of the company may be matched to modify parameters or conduct calibration (see "Programmer Instructions").

**2. Technology Parameters**

- **Allowed input signal:**  
Thermocouple: K, E, S, B, J, T, R, N and WRe3-WRe25, WRe5-WRe26,  
Thermal resistance: two-/three-wire system thermal resistance (Pt100,Cu50,Cu100,BA1,BA2, etc.)  
The type and range of input signal can be determined at the time of ordering or self-programmed.
- **Output signal type:**  
DC: 0(4)mA ~ 20mA; 0mA ~ 10mA;  
DC voltage: 0(1)V ~ 5V; 0V ~ 10V;  
Other signal types may be customized as required, see the product label for the specific signal types;
- **Output ripple:**<5mV rms (load 250Ω)
- **Accuracy of isolated transmission:**

(25°C±2°C, excluding cold junction compensation)

Input signal type		Range	Accuracy
TC	K/E/J/N, etc.	< 300 °C	±0.3 °C
		≥ 300 °C	±0.1% F·S
TC	S/B/T/R/WRe-series	< 500 °C	±0.5 °C
		≥ 500 °C	±0.1% F·S
RTD	Pt100/Cu100/Cu50	< 100 °C	±0.1 °C
	/BA1/BA2, etc.	≥ 100 °C	±0.1% F·S

- **Response time:** ≤0.5s
- **Temperature drift:** 40ppm/°C
- **Accuracy of cold junction temperature compensation:** ±1°C (preheating time of 10 minutes)
- **Range of cold junction temperature compensation:** -20°C ~ +60°C
- **Allowed lead resistance for measurement of thermal resistance:** ≤ 20Ω/lead
- **Load capacity:**  
0(4)mA ~ 20mA: ≤550Ω; 0mA ~ 10mA: ≤1.1kΩ  
0(1)V ~ 5V: ≥1MΩ; 0V ~ 10V: ≥2MΩ;
- **Full-load power consumption:**  
In case of 24V DC power supply and single-channel full-load output 0.7W

In case of 24V DC power supply and double-channel full-load output 1.3W

- **Range of service voltage:**18V DC ~ 32V DC (typical value: 24V DC)
- **Dielectric strength (leakage current 1mA, with test time of 1 minute):**  
≥2500V AC (between input/output and input/power supply)  
≥1500V AC (between output/power supply)
- **Insulation resistance:** ≥100MΩ (among input/output/power supply)
- **EMC:** EMC conforms to IEC61326-3

**3. Output Status:**

Follow-up mode: unless specially indicated by the user, no matter what kind of fault status occurs in the input signal (except disconnection, disconnection output 0 V/mA), the output will change following the input signal in the full-scale range, without exceeding 110% of the upper limit of the output range at a maximum (for example, in case of 0mA~20mA output, the minimum output can be 0mA, without exceeding 22mA at a maximum).

#### 4. Wiring Diagram:

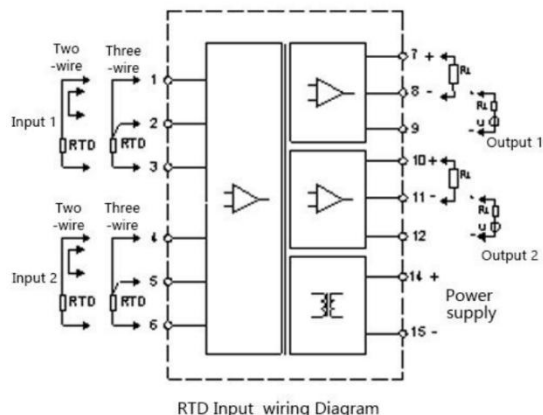
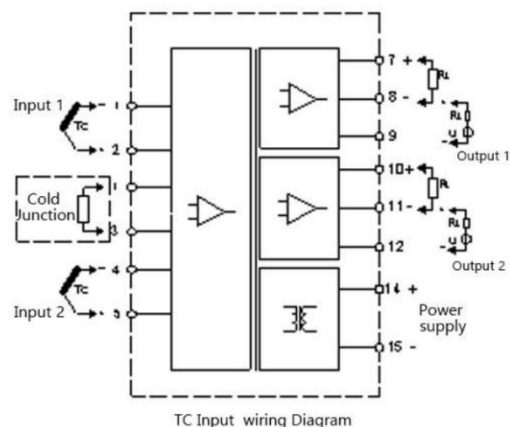

Note:

The cold junction compensation terminals have been set up before leaving the factory and shall not be plugged, pulled off or discarded at will when the thermocouple is input.

#### 5. Outline Dimensions

Width × Height × Depth  
(12.7mm×110mm×118.9mm)

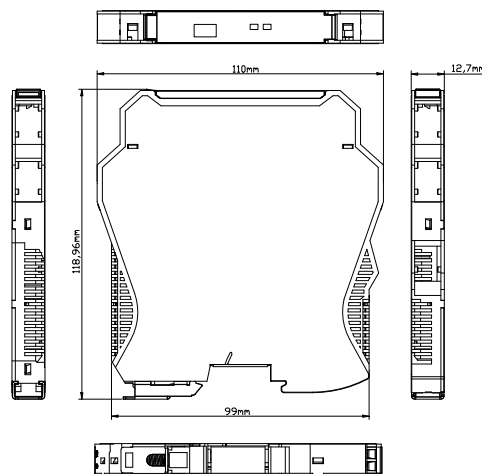

#### 6. Panel Indicator

- **PWR:** Power indicator (green). When the instrument is powered, it lights up all the time.
- **ALM:** Input signal status indicator, red. The indicator does not light up during normal operation; The indicator flashes in case of input signal failures; The indicator lights up all the time when the input signal is out of range.

#### 7. Operational Environment

- Ambient temperature during operation:  $-20^{\circ}\text{C} \sim +60^{\circ}\text{C}$
- Allowed relative humidity during

operation: 10%RH ~ 90%RH ( $40^{\circ}\text{C}$ )

- Allowed atmospheric pressure during operation: 80kPa ~ 106kPa
- Allowed ambient temperature during storage and transportation:  $-40^{\circ}\text{C} \sim +80^{\circ}\text{C}$

#### 8. Installation Method

- 35mm guide-rail type installation. Please position stably and firmly.
- Please install it as vertically as possible to facilitate heat dissipation inside the instrument.

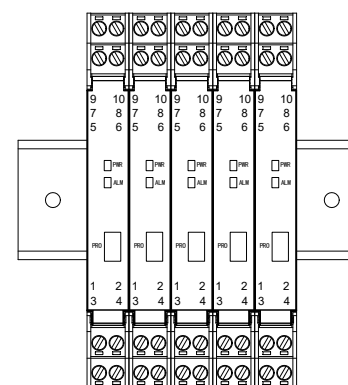

Vertical Installation Diagram

#### 9. Considerations

There shall not be strong vibration and the electromagnetic interference exceeding the intensity of Type 3 industrial field in the IEC61000-4 series from the signal terminal, power supply terminal and space at the installation location, and there shall be no harmful substances having serious

corroding effect on the metallic and plastic parts in the operational environment.

#### 10. Programming and Calibration

- There are two modes for programming and calibration of this product:
- On-site portable Chinese programmer: It can be used to for functional programming and measurement calibration of the instrument, provided with large-screen Chinese menu, which is of complete functions and convenient operation, but the price is higher;
- Simple programmer: single-line LCD menu operation, which can be used for functional settings of the instrument on the spot. It can be used and carried flexibly, and the price is economical;
- As this product adopts a digital structure and advanced technologies such as self-compensation of the ambient temperature and zero-point auto-calibration, the accuracy can be guaranteed within the specified range for many years without frequent calibration.

#### 11. Other Descriptions

In case of any unconformities between the contents in this instruction manual and the information of website and samples, etc., this instruction manual shall prevail.