

Features

1. Sealed with high-strength epoxy resin, no risk of arc leakage, ensuring no fire or explosion within the service life.
2. Potting with mainly nitrogen inert gas improves arc extinguishing performance and effectively prevents contact oxidation and burnout. The contact resistance is low and stable, and the contact part can meet the IP67 protection grade.
3. 30A 85°C long time current carrying capacity.
4. The insulation resistance reaches 100MΩ (1,000VDC), and the withstand voltage between the contact and the coil is 2.2kV.
5. Compliant with IEC 60664-1, GB/T14048.1 and GB/T14048.4 requirements.
6. Compliant with RoHS (2015/863/EC) and REACH (1907/2006/EC) requirements.
7. Safety certificate: CE, CCC, RoHS.

Main Contact Specification

Contact Arrangement	1K (1NO)
Contact Polarity	Non-polarity
Contact Resistance	≤0.5mΩ (at 30A)
Max. Switching Voltage	1,000VDC
Max. Breaking Current	250A (320VDC) 1 Ops
Electrical Endurance	10,000 Ops (1,500VDC, 30A)
	6,000 Ops (1,000VDC, 50A)
	20,000 Ops (750VDC, 30A)
	25,000 Ops (450VDC, 30A)
Mechanical Endurance	300,000 Ops
Withstand Current	30A, Continuous
	45A, 60min
	60A, 20min
	120A, 30S

Auxiliary Contact Parameter

Aux. Contact Arrangement	/
Aux. Contact Rated Current	/
Aux. Contact Max. Breaking Voltage	/

Performance Parameter (at 23℃)

Pickup Voltage	See Coil Parameter Tables	
Dropout Voltage	See Coil Parameter Tables	
Pickup Time	≤30ms	
Contact Bounce Period	≤5ms	
Dropout Time	≤10ms	
Dielectric Strength	Between Main Contacts	10000VDC 10s
	Between Main Contact and Coil	3500VDC 1min
Insulation Resistance	Initial State	100MΩ 1min
	After Electrical Life	50MΩ 1min
Shock	Stability	20g (Power On)
	Strength	50g
Vibration	10g, 10~500Hz, 1/2 Sine Wave (Power On)	
Relative Humidity	5%~95%RH	
Temperature	-40°C~85°C	
Load Terminal	M4 Internal Thread	
Weight	About 115g	
Dimension	51.7x36x46mm	
/	/	/
/	/	/

ADH30S Coil Parameter

Coil Voltage	Pickup Voltage VDC	Dropout Voltage VDC	Coil Resistance	Coil Power Consumption
12V	≤70%Us	5%-40%Us	≤0.33A	≤5W
24V	≤70%Us	5%-40%Us	≤0.17A	≤5W
36V	≤70%Us	5%-40%Us	≤0.12A	≤5W
48V	≤70%Us	5%-40%Us	≤0.09A	≤5W
60V	≤70%Us	5%-40%Us	≤0.07A	≤5W
72V	≤70%Us	5%-40%Us	≤0.06A	≤5W

Model Coding

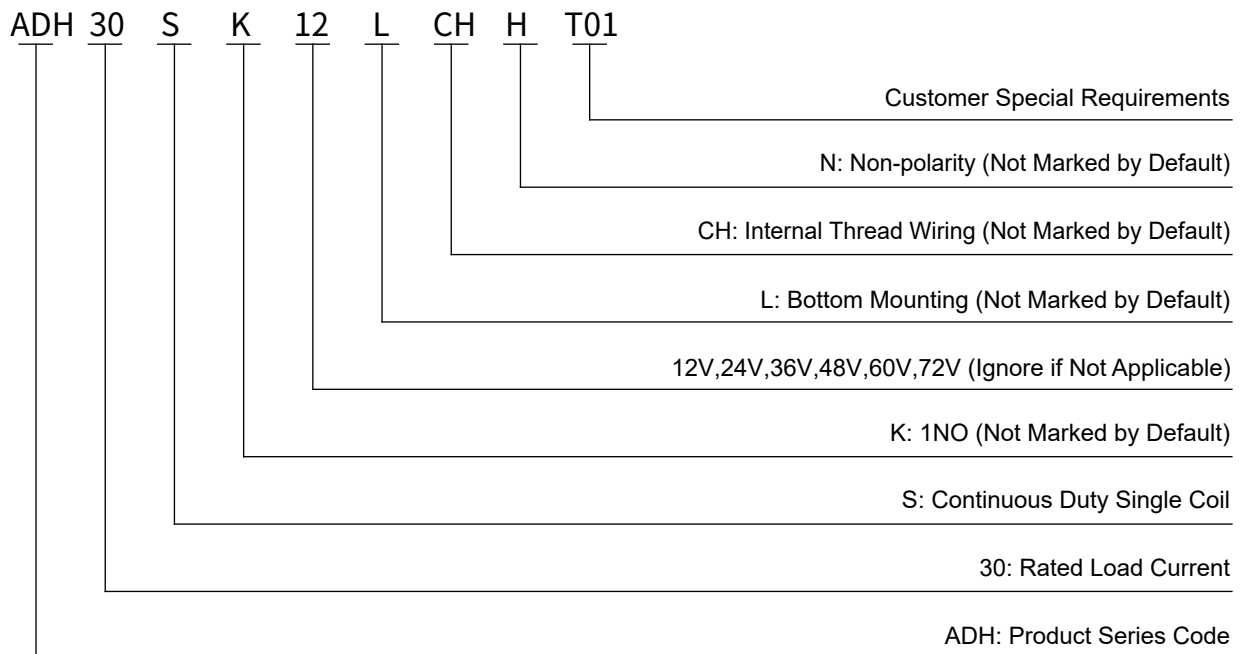

Wiring Diagram

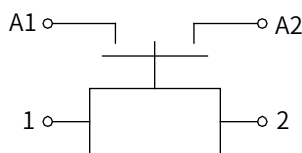

Wiring Diagram

Note: A1&A2 main terminals with non-polarity,
1&2 coil terminals with non-polarity.

Outline Installation Dimension Drawing

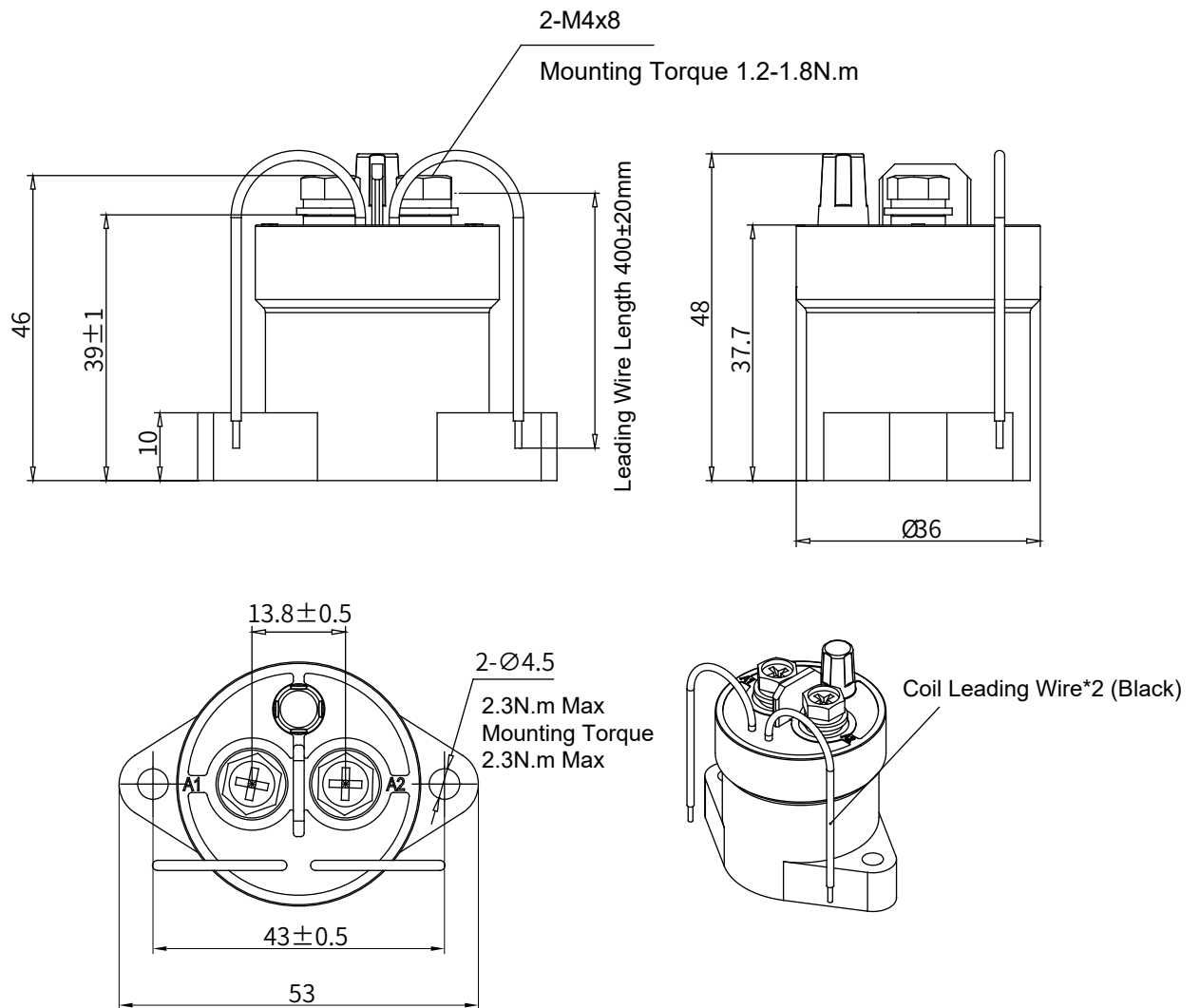

Usage Cautions

1. Regarding the application of this product, please select the matching product according to your specific use conditions and environmental requirements when selecting the product. If the requirements are not clearly specified, please contact ATO to obtain more technical support.
2. When installing and using this product, regardless of wiring or fixed installation, it is required to use anti-loose spring washers.
3. The torque for installing fasteners should be within the standard range required by this specification. It may cause the unstable installation or damaging the product if the torque is lower than the minimum torque or higher than the maximum torque.
4. Do not install the contactor in places with strong magnetic fields (such as transformers or strong magnets), or close to objects with thermal radiation. It is recommended to use it with a cooling fan.
5. It is forbidden to use the product in an environment with oil pollution, especially before wiring, it will seriously affect the main terminals conductivity if they are polluted by oil pollution, and affect the product life.
6. It is forbidden to use the product beyond the rated electrical life. When the rated electrical life is reached, although the product can continue to work, there is a risk of failure, explosion, and burning because of non-breaking.
7. When the main circuit voltage is $\geq 48V$, if the H suffix appears on the product label, it means that the main circuit wiring has the current direction, and the "+" terminal or the terminal with red paint must be connected to the positive pole of the power supply (battery).
8. This product cannot be used as a protector, and the circuit must be connected with a protector in series when using.
9. ATO only does the resistive electrical life verification and quality assurance. When the product is used in an environment with inductive load or capacitive load, it is recommended that the circuit should be connected in parallel with a surge protection device.
10. After continuous work, restart immediately after disconnection, the pickup voltage will be affected due to the heating state of the product, and it is reasonable that the pickup voltage will increase.
11. It is strictly prohibited to wiring when power on.
12. In principle, please do not use the contactor when it has dropped (height $\geq 30cm$).
13. ATO reserves the right to change the product. Customers should confirm the content of this specification before the first order, and can ask our company to provide a new specification if necessary.