



## Features

1. Sealed with high-strength epoxy resin, no risk of arc leakage, ensuring no fire or explosion within the service life.
2. Sealed with nitrogen-based inert gas to enhance the arc extinguishing performance, effectively preventing contact oxidation and burns. The contact resistance is low and stable, the contact parts meet IP67.
3. 50A 85°C long time current carrying capacity.
4. The insulation resistance reaches 100MΩ (1,000VDC), and the withstand voltage between the contact and the coil is 3.5kV.
5. Compliant with IEC 60664-1, GB/T14048.1 and GB/T14048.4 requirements.
6. Compliant with RoHS (2015/863/EC) and REACH (1907/2006/EC) requirements.
7. Safety certificate: CE, CCC, RoHS.

### Main Contact Specification

Contact Arrangement	1K (1NO)
Contact Polarity	Non-polarity
Contact Resistance	≤0.5mΩ (at 50A)
Max. Switching Voltage	1,000VDC
Max. Breaking Current	1,000A (320VDC) 1 Ops
Electrical Endurance (Resistive Load)	6,000 Ops (1,000VDC, 50A)
	8,000 Ops (750VDC, 50A)
	10,000 Ops (500VDC, 50A)
	50,000 Ops (110VDC, 50A)
	80,000 Ops (60VDC, 50A)
Mechanical Endurance	300,000 Ops
Withstand Current	50A, Continuous
	130A, 60min
	180A, 5min
	300A, 30S

### Auxiliary Contact Parameter

Aux. Contact Arrangement	FK/FB/FZ (1NO/1NC/1CO)
Aux. Contact Rated Current	5A
Aux. Contact Max. Breaking Voltage	120VDC

### Performance Parameter (at 23 °C)

Pickup Voltage	See Coil Parameter Tables	
Dropout Voltage	See Coil Parameter Tables	
Pickup Time	≤25ms	
Contact Bounce Period	≤5ms	
Dropout Time	≤10ms	
Dielectric Strength	Between Main Contacts	3,500VDC 1min
	Between Main Contact and Coil	3,500VDC 1min
Insulation Resistance	Initial State	100MΩ 1min
	After Electrical Life	50MΩ 1min
Shock	Stability	20g (Power On)
	Strength	50g
Vibration	10g, 10~500Hz, 1/2 Sine Wave (Power On)	
Relative Humidity	5%~95%RH	
Temperature	-40°C~85°C	
Load Terminal	M5 Internal Thread	
Weight	About 230g	
Dimension	55x42x64mm	
/	/	
/	/	
/	/	

## ADH50S Coil Parameters

Coil Voltage	Pickup Voltage VDC	Dropout Voltage VDC	Coil Resistance	Coil Power
12V	≤70%Us	5%-40%Us	24Ω±10%	6W±10%
24V	≤70%Us	5%-40%Us	96Ω±10%	6W±10%
48V	≤70%Us	5%-40%Us	384Ω±10%	6W±10%
60V	≤70%Us	5%-40%Us	600Ω±10%	6W±10%
72V	≤70%Us	5%-40%Us	864Ω±10%	6W±10%

## ADH50E Coil Parameter

Coil Voltage	Pickup Voltage VDC	Dropout Voltage VDC	Coil Resistance	Starting Power	Holding Power
9-36V	9-36V	5-7V	3.5Ω±10%	25W±10% (<30ms)	2.5W±20%

## Model Coding

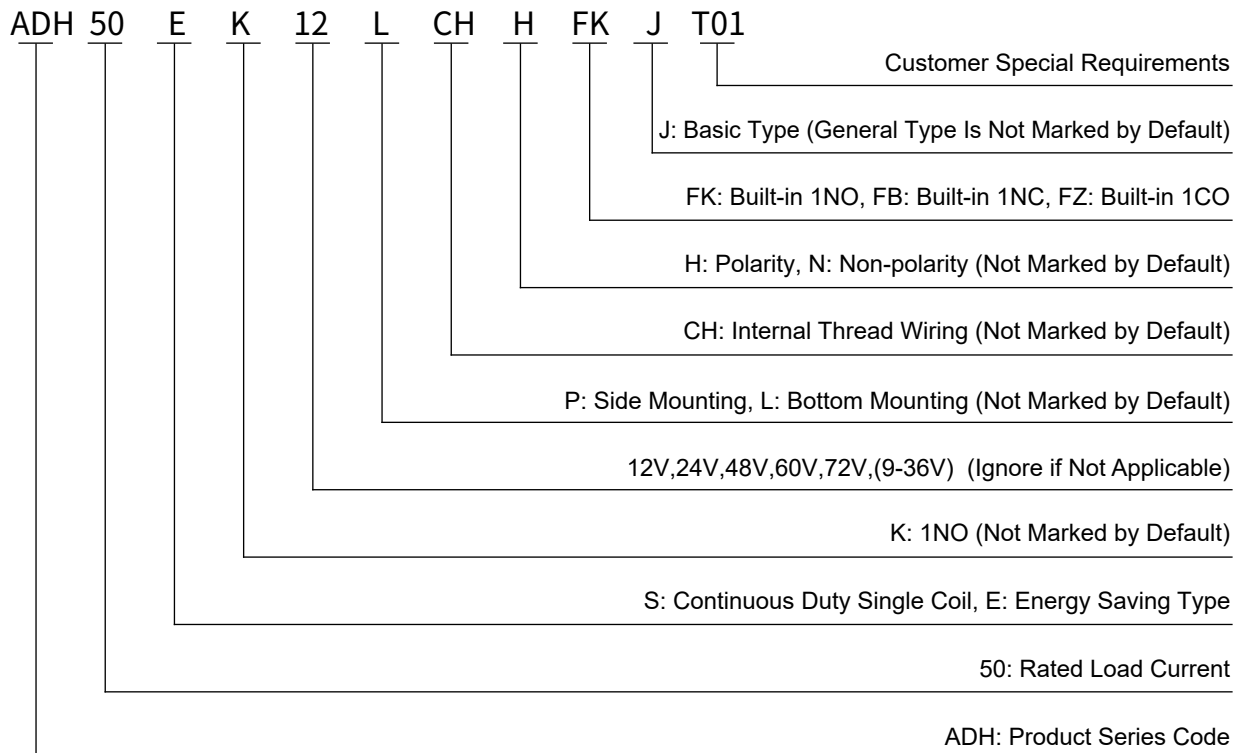

## Wiring Diagram

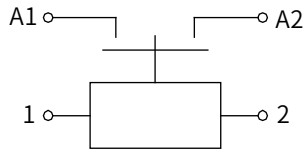

Wiring Diagram without Auxiliary Contact

Note: A1&A2 main terminals with non-polarity,  
3&4 auxiliary contact terminals,  
1&2 Circuit diagram.

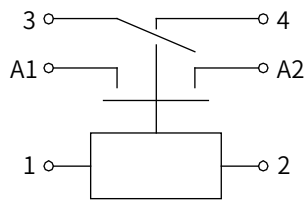

Wiring Diagram with 1NO Auxiliary Contact

## Outline Installation Dimension Drawing

ADH50S ADH50D

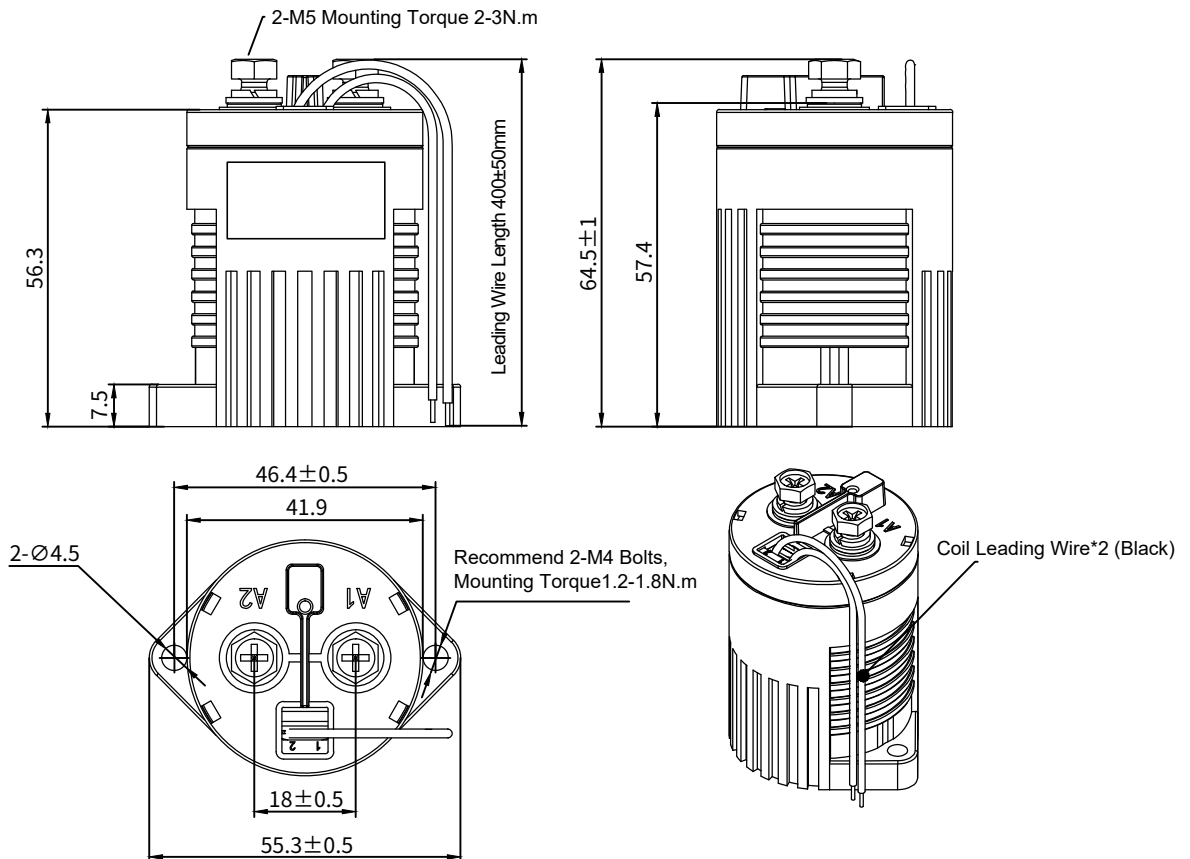

## Outline Installation Dimension Drawing

ADH50E Without Auxiliary Switch

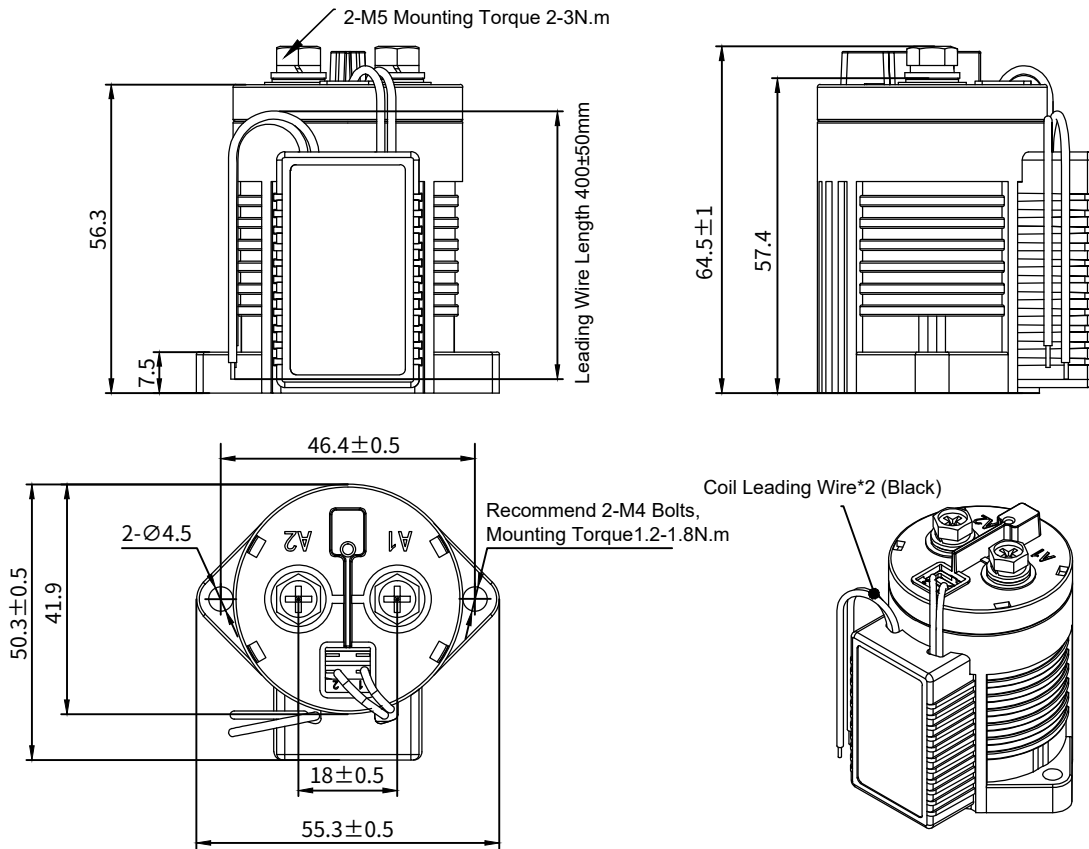

ADH50 With Auxiliary Switch

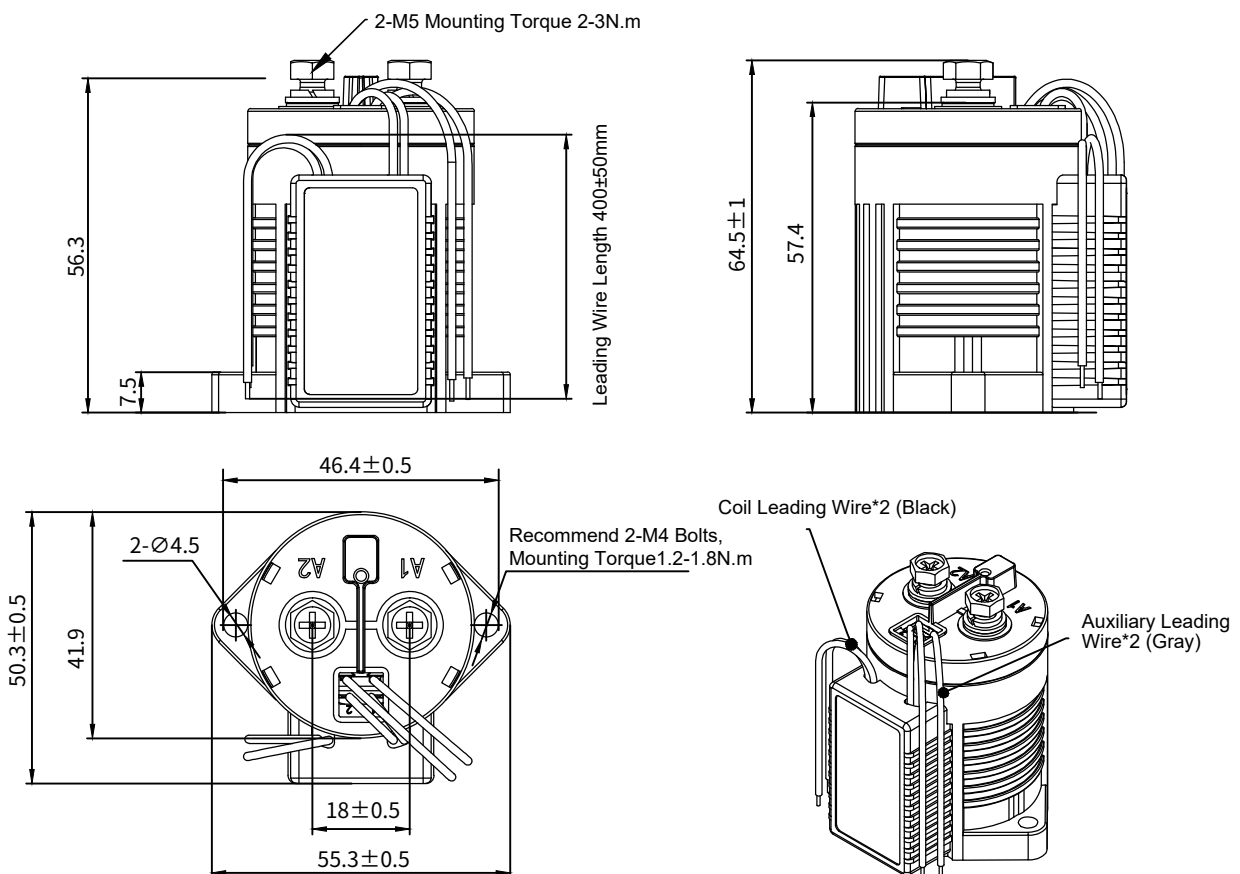

## Usage Cautions

1. Regarding the application of this product, please select the matching product according to your specific use conditions and environmental requirements when selecting the product. If the requirements are not clearly specified, please contact ATO to obtain more technical support.
2. When installing and using this product, regardless of wiring or fixed installation, it is required to use anti-loose spring washers.
3. The torque for installing fasteners should be within the standard range required by this specification. It may cause the unstable installation or damaging the product if the torque is lower than the minimum torque or higher than the maximum torque.
4. Do not install the contactor in places with strong magnetic fields (such as transformers or strong magnets), or close to objects with thermal radiation. It is recommended to use it with a cooling fan.
5. It is forbidden to use the product in an environment with oil pollution, especially before wiring, it will seriously affect the main terminals conductivity if they are polluted by oil pollution, and affect the product life.
6. It is forbidden to use the product beyond the rated electrical life. When the rated electrical life is reached, although the product can continue to work, there is a risk of failure, explosion, and burning because of non-breaking.
7. When the main circuit voltage is  $\geq 48V$ , if the H suffix appears on the product label, it means that the main circuit wiring has the current direction, and the "+" terminal or the terminal with red paint must be connected to the positive pole of the power supply (battery).
8. This product cannot be used as a protector, and the circuit must be connected with a protector in series when using.
9. ATO only does the resistive electrical life verification and quality assurance. When the product is used in an environment with inductive load or capacitive load, it is recommended that the circuit should be connected in parallel with a surge protection device.
10. After continuous work, restart immediately after disconnection, the pickup voltage will be affected due to the heating state of the product, and it is reasonable that the pickup voltage will increase.
11. It is strictly prohibited to wiring when power on.
12. In principle, please do not use the contactor when it has dropped (height $\geq 30$ cm).
13. ATO reserves the right to change the product. Customers should confirm the content of this specification before the first order, and can ask our company to provide a new specification if necessary.