

ATO

HU22: 24I

O wnk/Rct co gvgt 'Clt 'S wcnk 'Ugpuqt '
Wigt 'O cpwcn



Forget Wigt :

Thank you for choosing our product.

Before using this device, please read this manual carefully and follow the instructions for proper operation.

If you encounter any issues during use, please feel free to contact us.

Thank you for your cooperation!

This manual may be updated as the product improves. Please refer to the latest version for the most current information.

Table of Contents

Chapter 1: Product Overview -----	1
1.1 Product Introduction -----	1
1.2 Product Features -----	1
1.3 Application Scenarios -----	2
Chapter 2: Specifications -----	3
Chapter 3: Pin Definitions -----	5
Chapter 4: Appearance & Dimensions -----	6
Chapter 5: General Assembly Diagram -----	7
Chapter 6: Communication Protocol -----	8
6.1 Bluetooth Communication Protocol -----	8
6.2 WIFI Communication Protocol -----	9
Chapter 7: Communication Configuration -----	13
7.1 WIFI -----	13
Chapter 8: Reliability Test -----	15
Chapter 9: Precautions -----	17
Chapter 10: Model Number Naming Rules -----	18

Chapter 1: Product Overview

1.1 Product Introduction

FS00802G is an air quality detection product integrating 11 types of sensors. Multiple sensor combinations meet different application needs, external temperature and humidity sensors provide greater accuracy, and the screen cyclically displays real-time outputs. Each environmental parameter uses an independent sensor probe. It features compact design, small footprint, comprehensive functionality, stable performance, and high cost-effectiveness. It supports wireless communication methods such as WIFI, Bluetooth and the MQTT communication protocol, facilitating environmental quality monitoring and the development and application of IoT gas detection solutions.

Sensor Combinations	1	Laser Dust, TVOC, Formaldehyde, Carbon Dioxide, Atmospheric Pressure, 4 Types of Special Gases, Temperature & Humidity, Light
	2	Laser Dust, TVOC, Formaldehyde, Carbon Dioxide, Atmospheric Pressure, 3 Types of Special Gases, Noise, Temperature & Humidity, Light
	3	Laser Dust, TVOC, Ozone, Carbon Dioxide, Atmospheric Pressure, 4 Types of Special Gases, Temperature, Humidity, Light

1.2 Product Features

- Powerful functionality, capable of integrating 11 types of sensors simultaneously
- Easy installation, supports ceiling and wall mounting

- Flexible application, allows free combination of multiple sensors
- Accurate detection, responsive
- Supports wireless communication such as WIFI, Bluetooth
- MQTT communication protocol
- Supports custom development

1.3 Application Scenarios

- IoT devices, air quality detection
- Smart buildings, smart communities
- Public places such as schools, hospitals, supermarkets, subways
- Agricultural production, livestock farming

Chapter 2: Specifications

Parameter Type	Parameter Specification
Detection Gases	See Table 1 for details
Working Voltage	DC 10V~30V (Standard 24V)
Working Current	≤200mA
Preheat Time	3min
Detection Frequency	Default: 30s active upload interval
Output Mode	WIFI, Bluetooth
Communication Protocol	MQTT
Reference Dimensions	Φ144*41mm
Product Material	ABS Shell
Installation Method	Ceiling-mounted, Wall-mounted
Operating Temperature	-10°C~50°C
Operating Humidity	0%RH~95%RH (Non-condensing)
Storage Temperature	-30°C~ 60°C
Storage Humidity	0~99%RH (Non-condensing)
Packing List	Sensor Host Unit * 1 Expansion Screws * 4 sets Mounting Plate * 1 Certificate of Conformity * 1

Category	Type	Range	Resolution	Accuracy	Service Life (in air)
Conventional Gases	Temperature	-40°C~100°C	0.1°C	±0.3°C	10 Years
	Humidity	0~99%RH	0.1%RH	±3%RH	10Years
	pm2.5	0~1000µg/m ³	1µg/m ³	±10% Reading	≥40000 hours
	Carbon Dioxide	400~5000ppm	1ppm	± (50ppm+3% Reading)	10Years
	Formaldehyde	0~1500µg/m ³	1µg/m ³	±10% Reading	2Years
	TVOC	0~5000µg/m ³	1µg/m ³	±10% Reading	10Years
Special Gases	Ethanol	0~500mg/100ml	0.1mg/100ml	±10% Reading	2Years
	Ozone	0~10ppm	0.001ppm	±2% Reading	2Years
	Methane	0~100%LEL	1%LEL	±5% Reading	3Years
	Carbon Monoxide	0~1000ppm	1ppm	±3% Reading	2Years
	Oxygen	0~30%Vol	0.1%Vol	±0.5%VOL	2Years
	Ammonia	0~100ppm	0.1ppm	±5% Reading	2Years
	Hydrogen Sulfide	0~100ppm	0.1ppm	±5% Reading	2Years
	Chlorine	0~10ppm	0.1ppm	±3% Reading	2Years
	Nitrogen Dioxide	0~1000ppm	0.1ppm	±3% Reading	2Years
	Sulfur Dioxide	0~20ppm	0.1ppm	±3% Reading	2Years
Non-Gas	Atmospheric Pressure	30~110Kpa	0.1Kpa	±0.15Kpa@25°C 75Kpa	3Years
	Noise	30db~130db	0.1db	±1db	3Years
	Illuminance	0~200K Lux	1Lux	±7%@25°C	3Years

Note: For more detectable gas types, please consult relevant staff; Customization of supported gas types and specifications is available.

Table 1

Chapter 3: Pin Definitions



	PIN	Definition	Description
USB Version 802G	VIN	VIN	Connect to 24V Power Supply +
	GND	GND	Connect to 24V Power Supply -
	USB	USB	Wireless Communication Configuration Port

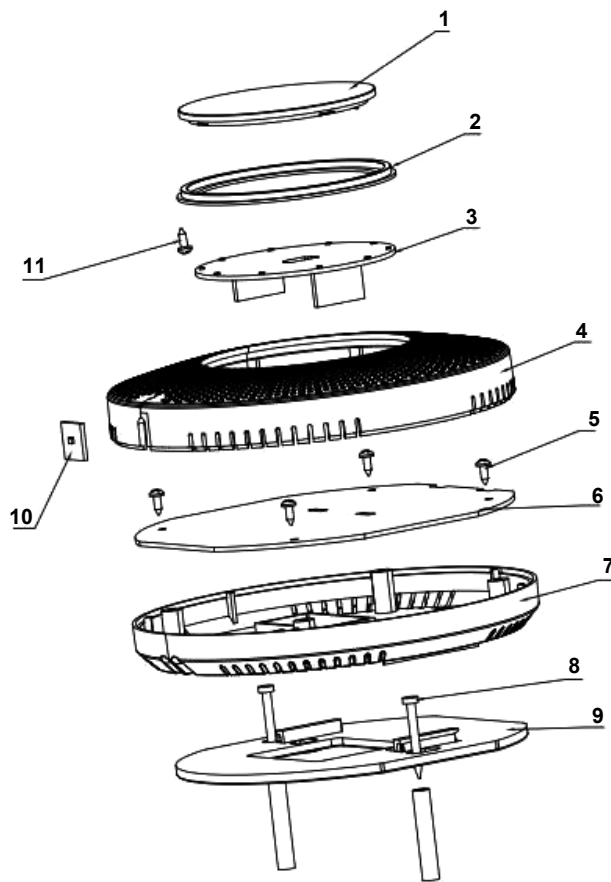

Chapter 5: General Assembly Diagram

1. Front Panel
2. .Light Ring
3. Light Board PCB
4. Upper Housing
5. Phillips Countersunk Self-tapping Screw*4
6. Main Board PCB
7. Bottom Housing
8. Expansion Bolt*2
9. Mounting Bracket
10. Temperature and humidity PCB
11. Phillips Countersunk Self-tapping Screw*1

Chapter 6: Communication Protocol

6.1 Bluetooth Communication Protocol

After the host successfully connects to the device via Bluetooth, the device actively uploads data in JSON format, with a default interval of 30 seconds.

5.1 Bluetooth Communication Protocol - Device Upload Data (json Format)					
Number	Attribute	Data Type	Name	Unit	Remarks
1	pm25	float	PM2.5	ug/m ³	
2	pm1.0	float	PM1.0	ug/m ³	
3	pm10	float	PM10	ug/m ³	
4	temperature	float	temperature	°C	
5	humidity	float	humidity	%	
6	atmosphere	float	atmosphere	kPa	
7	Light	int	Light	lux	
8	ex	float	Combustible Gas (EX)	%LEL	
9	hcho	int	Formaldehyde	ug/m ³	
10	h2s	float	Hydrogen sulfide (H2S)	ppm	
11	co	float	Carbon monoxide (CO)	ppm	
12	o2	float	Oxygen (O2)	percentage	
13	so2	float	Sulfur dioxide (SO2)	ppm	
14	ch4	float	Methane (CH4)	percentage	
15	no	float	Nitric oxide (NO)	ppm	
16	no2	float	Nitrogen dioxide (NO2)	ppm	
17	cl2	float	Chlorine gas (CL2)	ppm	
18	nh3	float	Ammonia (NH3)	ppm	
19	h2	float	Hydrogen (H2)	ppm	
20	hcn	float	Hydrogen cyanide (HCN)	ppm	
21	hcl	float	Hydrogen chloride (HCL)	ppm	
22	ph3	float	Phosphine (PH3)	ppm	
23	o3	float	Ozone (O3)	ppm	
24	clo2	float	Chlorine dioxide(CLO2)	ppm	
25	ch2o	float	Formaldehyde(CH2O)	ppm	
26	c2h4o	float	Acetaldehyde(C2H4O)	ppm	
27	co2	float	Carbon dioxide(CO2)	ppm	
28	tvoc	int	TVOC	ug/m ³	
29	c6h6	float	Benzene(C6H6)	ppm	
30	c7h8	float	Toluene(C7H8)	ppm	

31	nox	float	Nitrogen oxides (NOx)	ppm	
32	br2	float	Bromine gas (Br2)	ppm	
33	hf	float	Hydrogen fluoride (HF)	ppm	
34	timestamp	string	The timestamp unit is ms	ms	Not parsing
35	deviceid	string	Unique Equipment Number		
36	crc	string	Crc verification value		Not parsing

Note: If a specific sensor is not present, the corresponding field should be written as "#". If sensor data is abnormal, the corresponding field should be "*".

6.2 WIFI Communication Protocol

The device uses the MQTT communication protocol and uploads data every 30 seconds by default.

5.2 WIFI Communication Protocol		
MQTT Server Login Information		
MQTT_URI		To be written later via tool
PORT		
Client ID		
MQTT_USERNAME		
MQTT_PASSWORD		
Publish Topic (Data)	fs/lot/env_quality_v1/deviceid/up	Deviceid variable
Subscribe Topic (Downlink)	fs/lot/env_quality_v1/deviceid/down	Deviceid variable
Subscribe Topic (Response)	fs/lot/env_quality_v1/deviceid/reply	Deviceid variable

Downlink Topic fs/lot/env_quality_v1/deviceid/down (Data format is json)		
Attribute	Data Type	Description
deviceid	string	Device unique ID
cmd	int	0: Control buzzer
value	int	1: Turn on buzzer 2: Turn off buzzer
Buzzer frequency is 0.5s		

Response Topic: fs/lot/env_quality_v1/deviceid/reply (Data format is json)		
Attribute	Data Type	Description
deviceid	string	Device unique ID
reply	int	1: Device received successfully
{"deviceid":"250318","reply":1}Device responds, reporting acknowledgment to the server.		

Example
<p>Buzzer Control:: Downlink Topic fs/lot/env_quality_v1/250318/down Downlink Content {"deviceid":"250318""cmd":0,"value":1}Control buzzer and turn it on. {"deviceid":"250318""cmd":0,"value":0}Control buzzer and turn it off. Response Topic fs/lot/env_quality_v1/250318/reply Response Content {"deviceid":"250318","reply":1}Device responds and sends acknowledgment to the server.</p> <p>Light Control: Downlink Topic fs/lot/env_quality_v1/250318/down Downlink Content {"deviceid":"250318","cmd":1,"value":0}Light off {"deviceid":"250318","cmd":1,"value":1}Red light on {"deviceid":"250318","cmd":1,"value":2}Yellow light on {"deviceid":"250318","cmd":1,"value":3}Green light on Response Topic fs/lot/env_quality_v1/250318/reply Response Content {"deviceid":"250318","reply":1}Device responds and sends acknowledgment to the server.</p> <p>Remark: The downlink content provided is a reference example; in practice, only one command item should be sent per downlink message.</p>

5.2.3 Device Upload Data (jsonFormat) -WIFI/vision					
fs/lot/env_quality_v1/deviceid/up					
Number	Attribute	Data Type	Name	Unit	Remarks
1	pm25	float	PM2.5	ug/m ³	
2	pm1.0	float	PM1.0	ug/m ³	
3	pm10	float	PM10	ug/m ³	
4	temperature	float	temperature	°C	
5	humidity	float	humidity	%	
6	atmosphere	float	atmosphere	kPa	
7	lv	int	Light	lux	
8	ex	float	Combustible Gas (EX)	%LEL	
9	hcho	int	Formaldehyde	ug/m ³	
10	h2s	float	Hydrogen sulfide	ppm	

			(H2S)		
11	co	float	Carbon monoxide (CO)	ppm	
12	o2	float	Oxygen (O2)	%	
13	so2	float	Sulfur dioxide (SO2)	ppm	
14	ch4	float	Methane (CH4)	%	
15	no	float	Nitric oxide (NO)	ppm	
16	no2	float	Nitrogen dioxide(NO2)	ppm	
17	cl2	float	Chlorine gas (CL2)	ppm	
18	nh3	float	Ammonia (NH3)	ppm	
19	h2	float	Hydrogen (H2)	ppm	
20	hcn	float	Hydrogen cyanide (HCN)	ppm	
21	hcl	float	Hydrogen chloride (HCL)	ppm	
22	ph3	float	Phosphine (PH3)	ppm	
23	o3	float	Ozone (O3)	ppm	
24	clo2	float	Chlorine dioxide (CLO2)	ppm	
25	ch2o	float	Formaldehyde (CH2O)	ppm	
26	c2h4o	float	Acetaldehyde (C2H4O)	ppm	
27	co2	float	Carbon dioxide (CO2)	ppm	
28	noise	float	Noise	db	
29	sf6	float	sulfur hexafluoride	ppm	
30	tvoc	int	TVOC	ug/m ³	
31	c6h6	float	Benzene (C6H6)	ppm	
32	c7h8	float	Toluene (C7H8)	ppm	
33	nox	float	Nitrogen oxides (NOx)	ppm	
34	br2	float	Bromine gas (Br2)	ppm	
35	hf	float	Hydrogen fluoride (HF)	ppm	
36	timestamp	string	The timestamp unit is ms	ms	
37	iccid	string	SIM card number		
38	imei	string	Network Access License		
39	PositionX	float	Dimension	degree	
40	PositionY	float	longitude	degree	
41	deviceid	string	Unique Equipment Number		
42	human	Int	Human Presence (1: Occupied, 0: Unoccupied)		

Note: If a specific sensor is not present, the corresponding field should be written as "#". If sensor data is abnormal, the corresponding field should be "*".

Chapter 7: Communication Configuration

7.1 WIFI

- ① Correctly connect the power and signal lines according to the pin definitions.
- ② Run the 802G configuration software and configure the (232) serial port parameters (default: 115200, 8N1).

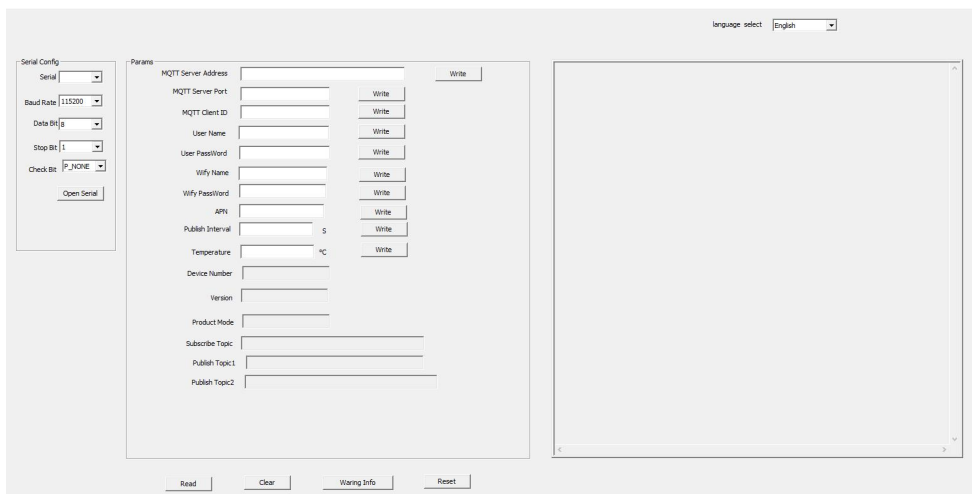

- ③ Click "Open Serial Port", first clear parameters, then read parameters.

If there is no data or garbled characters, check whether the wiring is correctly connected according to the pin definitions, and for the WIFI version, check if the firewall is turned off.

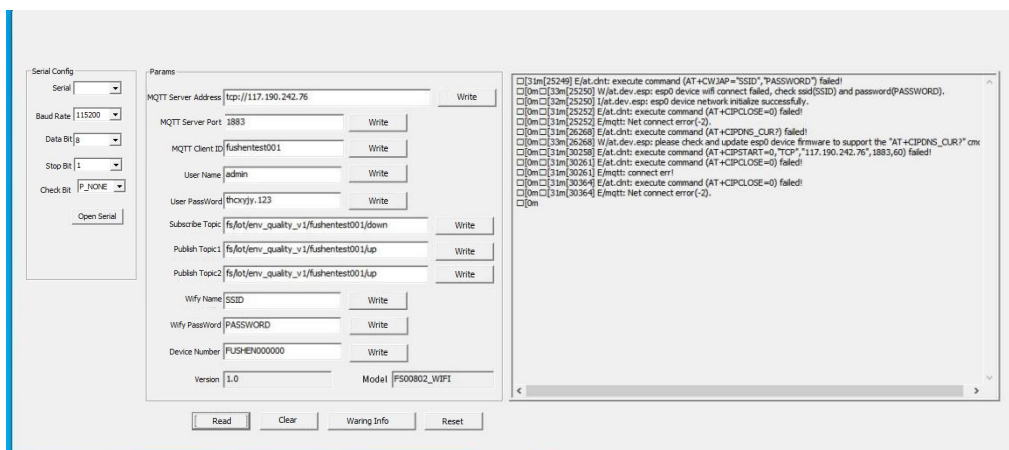

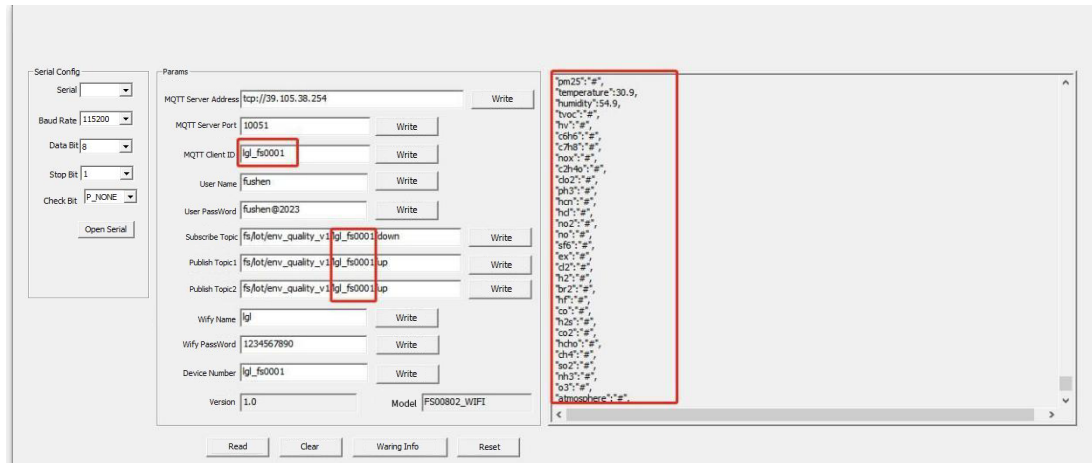

Chapter 8: Reliability Test

Test Items	Test Conditions	Standards	Number of samples: N
			Number of defects:C
Low-Temperature Storage	Store the sensor at $-30\pm 2^{\circ}\text{C}$ without power for 72 hours, then measure its error at room temperature.	After 2 hours of recovery in a normal environment, the sensor should function properly.	N=5 C=0
High-Temperature Storage	Store the sensor at $60\pm 2^{\circ}\text{C}$ without power for 72 hours, then measure its error at room temperature.	After 2 hours of recovery in a normal environment, the sensor should function properly.	N=5 C=0
Low-Temperature Operation	Operate the sensor at $-10\pm 2^{\circ}\text{C}$ with rated voltage for 72 hours, then measure its error at room temperature.	After 2 hours of recovery in a normal environment, the sensor should function properly.	N=5 C=0

High-Temperature Operation	Operate the sensor at $50\pm 2^{\circ}\text{C}$ with rated voltage for 72 hours, then measure its error at room temperature.	After 2 hours of recovery in a normal environment, the sensor should function properly.	N=5 C=0
Thermal Shock	Cycle between -30°C (60 min) and 60°C (60 min) for 10 cycles, with a transition time of $\leq 10\text{s}$. No power during testing.	After 2 hours of recovery in a normal environment, the sensor should function properly.	N=5 C=0
High-Temperature & High-Humidity Operation	Operate the sensor at $45\pm 2^{\circ}\text{C}$, $90\pm 5\%$ RH with maximum rated voltage for 72 hours.	After 2 hours of recovery in a normal environment, the sensor should function properly.	N=5 C=0
Salt Spray Test	Expose the sensor to a 5% NaCl mist at 35°C for 24 hours per GB/T 2423.17. Rinse with distilled water and air-dry after testing.	After 1–2 hours of recovery, no visible corrosion or damage. Functional performance must meet specifications.	N=2 C=0
Vibration Test	Subject the bare sensor to vibration on X/Y/Z axes under the following conditions: <ul style="list-style-type: none"> • Frequency: $10\rightarrow 55\rightarrow 10\text{ Hz/min}$ • Amplitude: 1.5 mm • Duration: 2 hours per axis. 	No physical damage. Functional performance must meet specifications after testing.	N=4 C=0
Packaging Drop Test	Drop height determined per GB/T 4857.18 (weight-based). Test sequence: 1 corner, 3 edges, 6 faces (GB/T 4857.5).	No physical damage, loose components, or functional degradation after testing.	N=1 C=0

Chapter 9: Precautions

- The dust sensor on this module is suitable for detecting particulate matter in ordinary indoor environments. The actual usage environment should try to avoid oily smoke environments, excessive particulate matter, high humidity environments, etc., such as: kitchens, bathrooms, smoking rooms, outdoor environments, etc. If used in such environments, corresponding protective measures should be added to the device to avoid sticky particles or large particles entering the sensor interior, forming deposits inside the sensor and affecting its performance.
- The sensor should avoid contact with organic solvents (including silicone and other adhesives), coatings, chemicals, oils, and high-concentration gases.
- The sensor must not be completely encapsulated with resin materials nor submerged in an oxygen-free environment, as this will damage its performance.
- The sensor should not be used for extended periods in environments containing corrosive gases, as corrosive gases can damage the sensor.
- Some sensors require a preheating time of more than 3 minutes upon initial power-on.
- Do not use this sensor in systems related to personal safety.
- If the sensor needs to be placed in a confined space, this space should be well-ventilated.

- Do not install or use the sensor in environments with strong convective air.
- Do not place the sensor in high concentrations of organic gases for extended periods, as this can cause the sensor's zero point to drift and recover slowly.
- It is prohibited to encapsulate the sensor using hot melt adhesive or sealants with a curing temperature exceeding 80°C.
- The sensor should be kept away from heat sources and avoid direct sunlight or other heat radiation.
- The sensor should not be subjected to excessive impact or vibration.

Chapter 10: Model Number Naming Rules

