



76 – 81 GHz Frequency Modulated Continuous Wave (FMCW)
Radar Level Transmitter
Installation and Operation Manual



1. Introduction

1.1 Features

The 76–81 GHz Frequency Modulated Continuous Wave (FMCW) radar level transmitter supports both two-wire and four-wire configurations. Depending on the model, the maximum measuring range can reach up to 120 m, with a minimum blind zone of 8 cm. With its higher operating frequency and shorter wavelength, the transmitter is particularly suitable for solid material applications. It operates using a lens-based electromagnetic wave transmission and reception system, ensuring reliable performance in harsh conditions such as heavy dust and high temperatures (up to 200°C). The device is available with flange or threaded process connections, allowing for easy and flexible installation.

Key Advantages:

- Incorporates a self-developed CMOS millimeter-wave RF chip, enabling a more compact RF design, higher signal-to-noise ratio, and reduced blind zone.
- Wide 5 GHz bandwidth ensures higher measurement resolution and accuracy.
- Ultra-narrow beam angle (as low as 3°) minimizes interference from surrounding structures and simplifies installation.
- Shorter wavelength provides improved reflectivity on solid surfaces, eliminating the need for a swivel (universal) flange for alignment.
- Supports remote commissioning and firmware upgrades, reducing downtime and improving operational efficiency.
- Supports Bluetooth commissioning via mobile devices, facilitating convenient on-site maintenance.

Communication and Commissioning

The transmitter can be commissioned locally via the integrated display module (ICD) or remotely using optional PC software. Communication between the transmitter and external devices can be established through the following methods:

1. USB-to-RS485 converter (for four-wire configuration)
2. USB-to-TTL serial converter (for two-wire configuration)
3. USB-to-HART modem (for two-wire configuration)

Additionally, Bluetooth connectivity enables commissioning via mobile devices, improving convenience and safety during on-site operations. Remote commissioning is also supported via a 4G communication module, allowing configuration and diagnostics from remote locations.

1.2 Selection Guide

76–81 GHz FMCW Radar

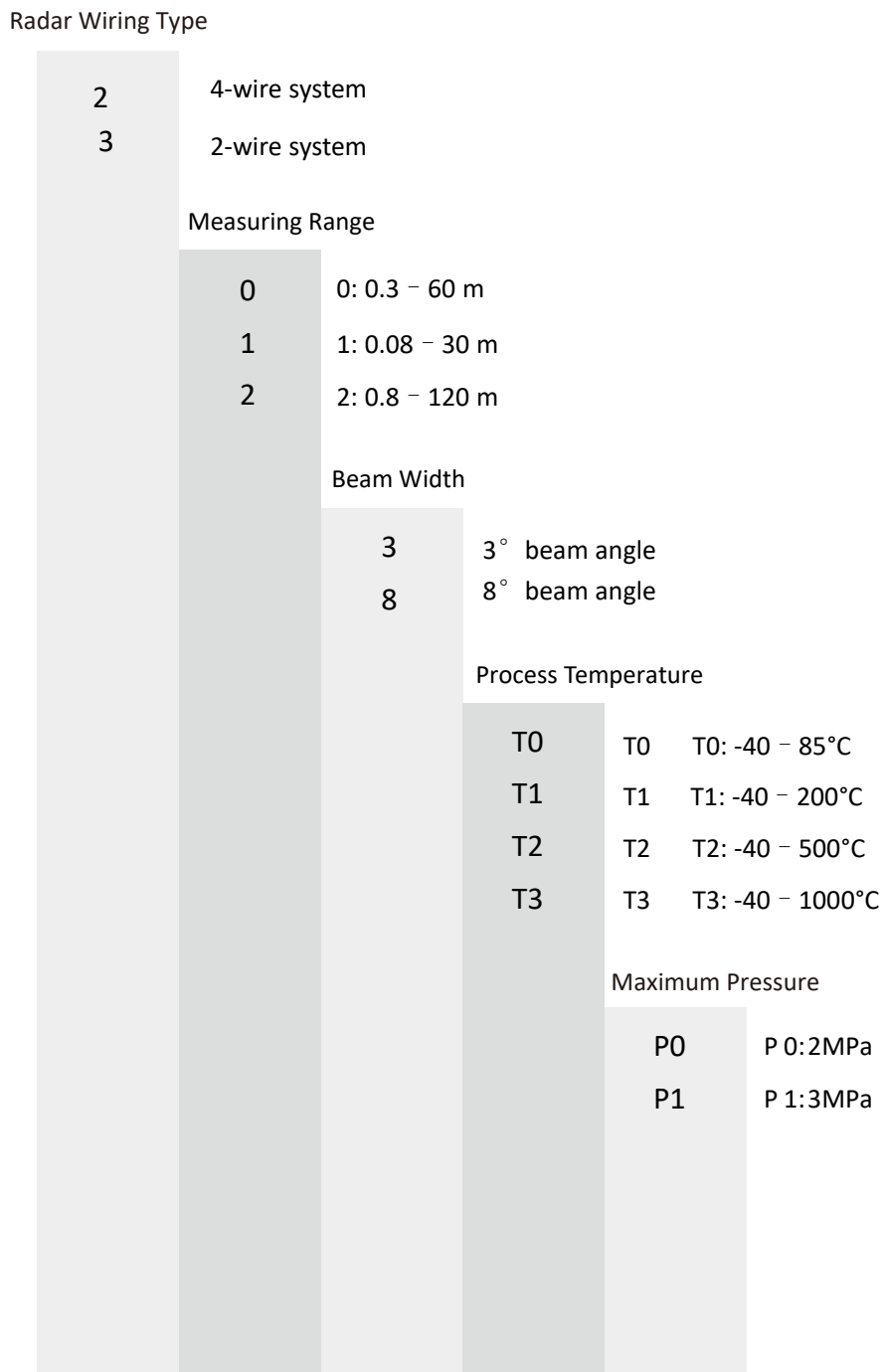

Figure 1-1 Selection Reference

2. Technical Specifications

Table 2-1 Technical Specifications

Transmission Frequency	76 GHz–81 GHz
Measuring Range	0.3 m–60 m (solids) 0.08 m–30 m (liquids) 0.6 m–120 m (solids)
Measurement Accuracy	±0.7 mm
Beam Angle	3° / 8°
Dielectric Constant Range	≥ 1.5
Power Supply Range	15–28 VDC 4-wire system 2-wire system
Communication Protocols	MODBUS HART
Signal Output	4–20mA / RS-485
Fault Output	3.8mA, 4mA, 20mA, 21mA, Hold
Local Operation / Programming	128 × 64 dot matrix display / 4 keys PC configuration software available
Process Temperature / Humidity	T0: -40 – 85°C / ≤95% RH T1: -40 – 200°C T2: -40 – 500°C T3: -40 – 1000°C
Housing Material	Aluminum alloy, stainless steel
Antenna Type	Waveguide antenna; optional lens antenna / anti-corrosion antenna / antenna heat dissipation paste / quartz isolation flange
Process Pressure	-0.1–2 MPa
Product Dimensions	Ø100 × 270 mm
Cable Entry	M20 × 1.5
Recommended Cable	AWG18 / 0.75 mm ²
Protection Rating	IP67
Explosion Protection Rating	Ex d IIC T6
Installation Method	Threaded / flange mounting
Net / Gross Weight	2.480 kg / 2.955 kg
Packaging Dimensions	370 × 270 × 180 mm

3. Structure & Dimensions

3° Beam Angle Structure

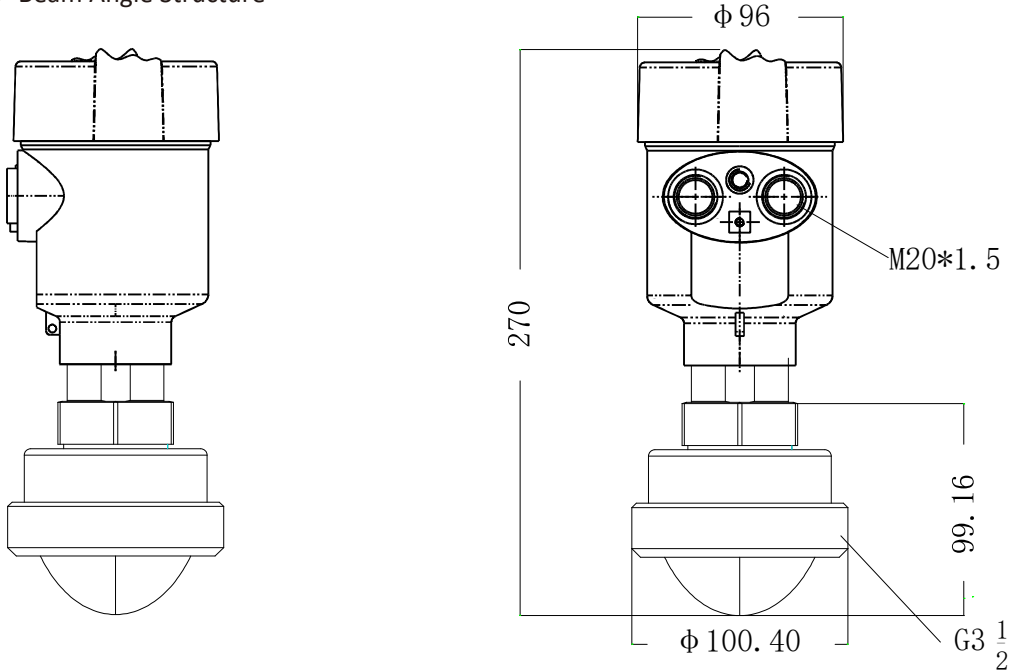

8° Beam Angle Structure

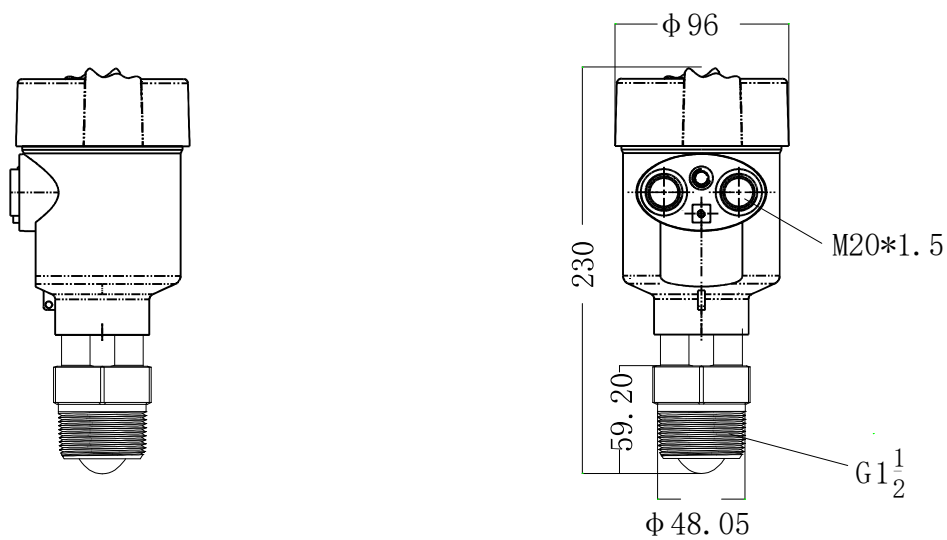
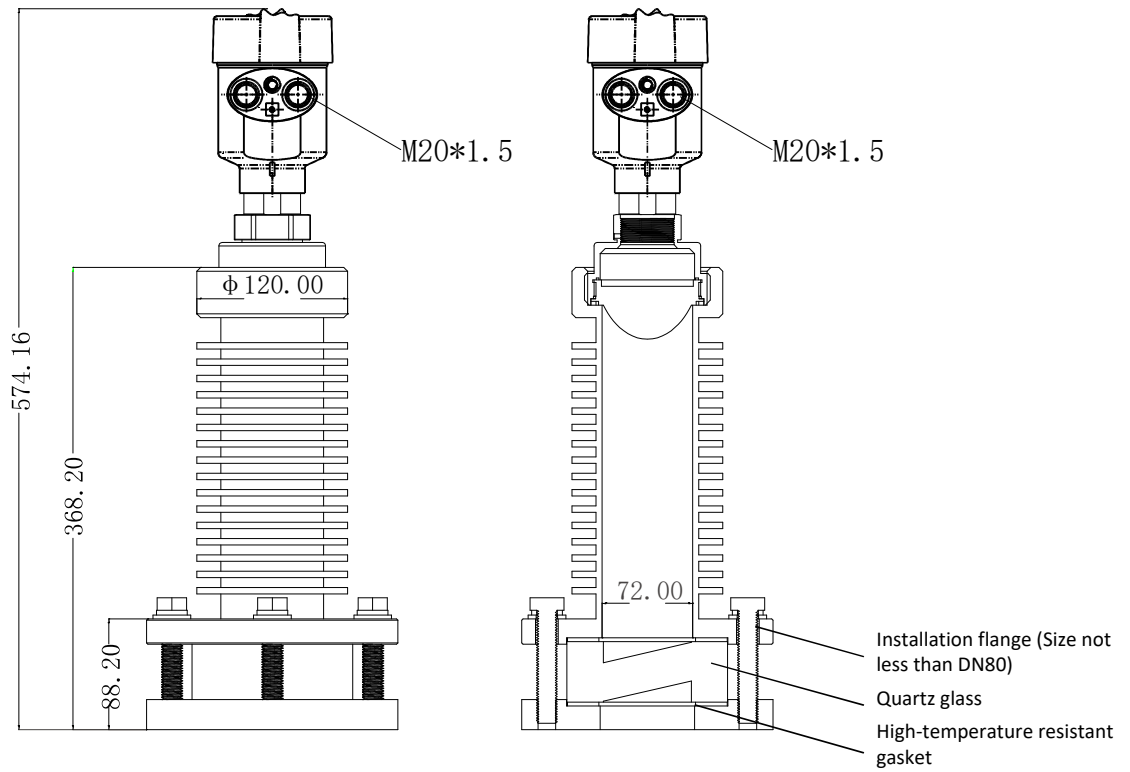

Figure 3-1 Structure and Dimensions

3° Beam Angle High-Temperature Resistant Structure



8° Beam Angle High-Temperature Resistant Structure (applicable to T2 and T3)

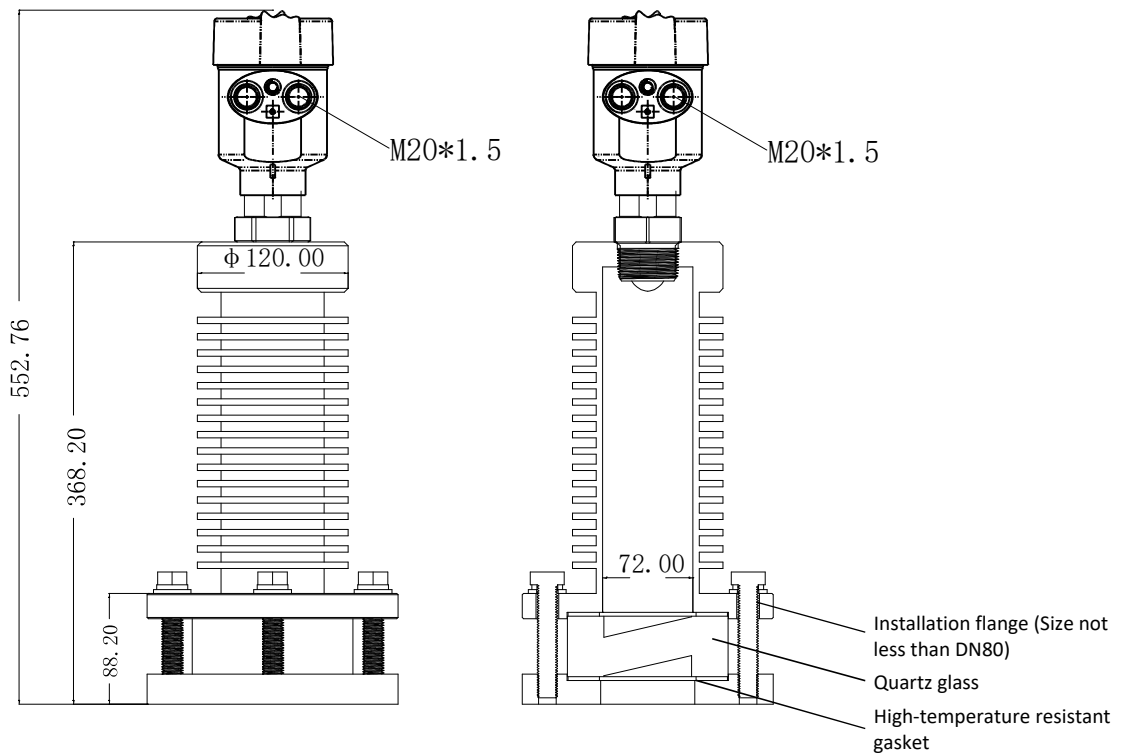

Figure 3-2 High-Temperature Resistant Structure (applicable to T2 and T3)

4. Installation

There are two key points to note during installation:

- (1) Align with the target material level and ensure near-vertical incidence to the material surface;
- (2) Avoid false echoes. Typical installation conditions are as follows:

- Ensure no interfering objects are within the beam range, such as ladders or platforms.

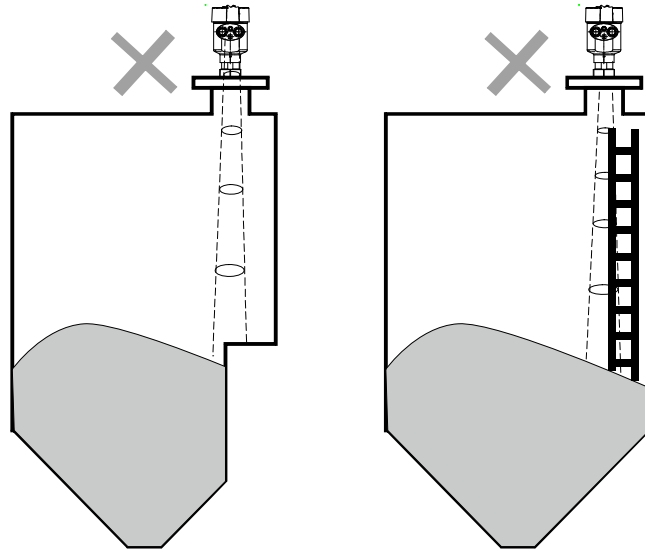

Figure 4-1 Instrument Installation Position Diagram

- The antenna beam shall be kept away from the feed inlet, as shown in Figure 4-2.

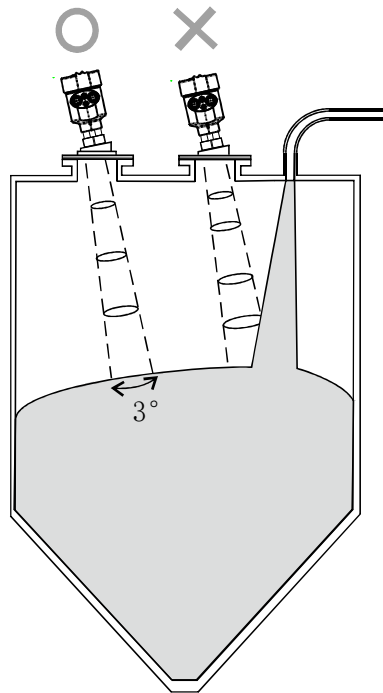

Figure 4-2 Antenna Beam Avoiding Feed Inlet

- The instrument shall be installed at least 200 mm away from the vessel wall; otherwise, incorrect readings may occur.

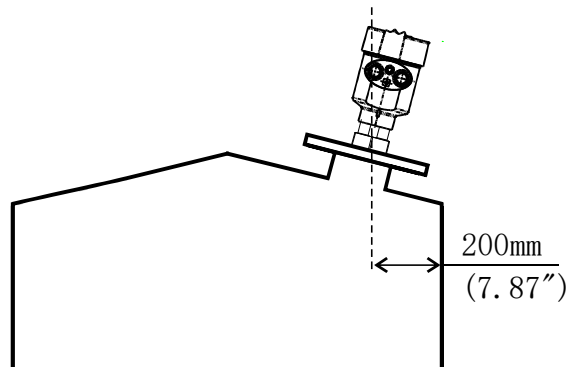

Figure 4-3 Minimum 200 mm Distance from Vessel Wall

- For conical vessels, maintain vertical beam alignment toward the tank bottom to ensure measurement accuracy.

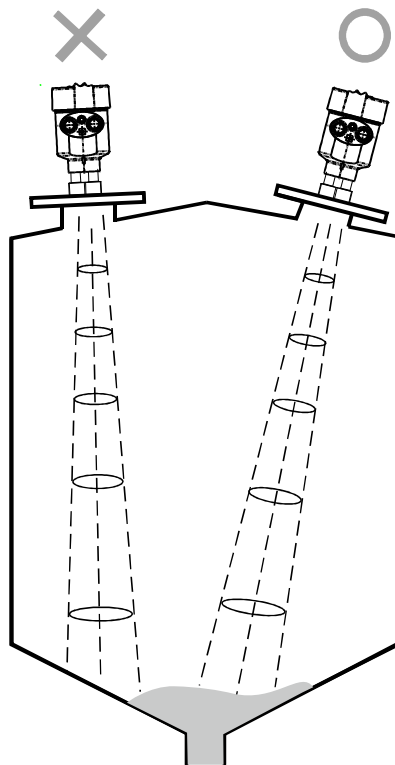

Figure 4-4 Beam Alignment in Conical Tanks

5. Wiring

5.1 24 VDC Power Supply, 4-Wire System (Single Chamber)

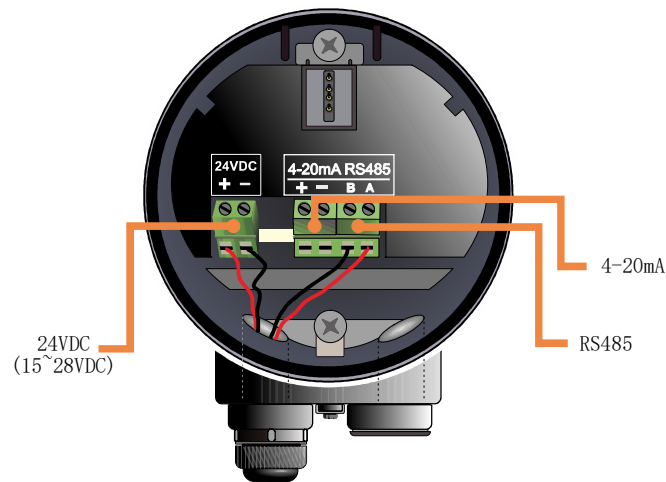

Figure 5-1 4-Wire System Wiring Diagram

In the 4-wire system, the 4–20mA analog output is provided on a separate pair of terminals, independent of the 24 VDC power supply terminals. The 4-wire version also includes RS-485 communication terminals, enabling connection to a PC for commissioning or integration with RS-485-based systems.

5.2 24 VDC Power Supply, 2-Wire System (Single Chamber)

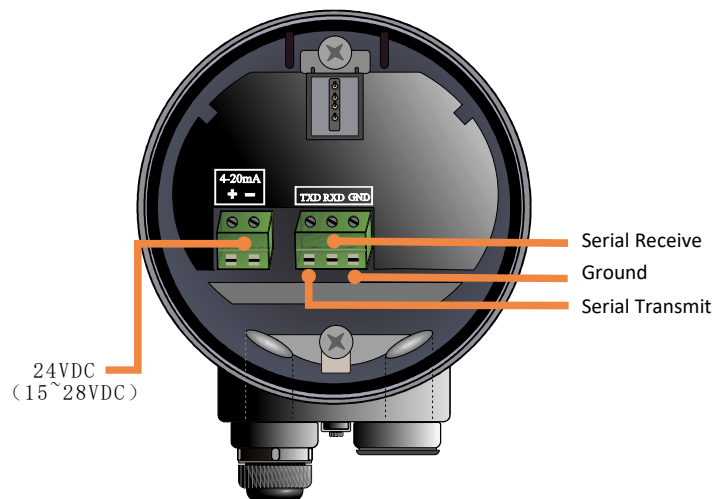

Figure 5-2 2-Wire System Wiring Diagram

In the 2-wire system, the instrument operates on a loop-powered 4 –20mA signal. It is also equipped with serial communication terminals, enabling connection to mainstream IoT systems or data transmission gateways for remote configuration and commissioning.

6. Operation

The instrument performs level measurement according to the configured parameters. These parameters can be modified via the Local Display Module (LDM). The LDM consists of four push buttons and a 128×64 dot-matrix LCD display.

6.1 Key Description

The system provides five operating modes:

[Run Mode]: Displays system status and current measurement values.

[Echo Mode]: Displays real-time echo signal information.

[Memo Mode]: Displays historical measurement data and operating records.

[Setup Mode]: Used to configure system parameters.

[Input Mode]: Used for entering numeric or alphanumeric parameter values.

The function of each key varies depending on the active operating mode.

6.2 Measurement Interface Description

Table 6-1 Key Function Description in Measurement Interface

Key	Function
ESC	Switch to Echo Curve Interface
UP	-NULL
DN	-NULL
ENT	Switch to Parameter Setting Interface

■ Measurement Interface Display:

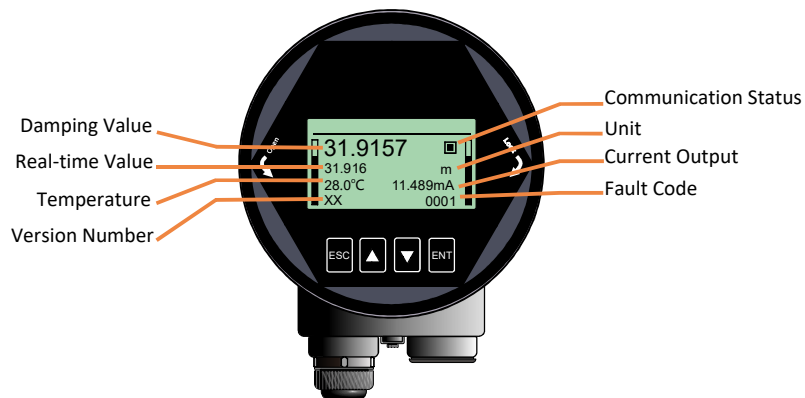

Figure 6-1 Measurement Interface Diagram

- **Real-time Value:** Indicates the current measurement result of the system. This value is calculated from the real-time distance between the sensor reference point and the material surface. The conversion method depends on the sensor mode and the upper/lower level adjustment points (see Section 6.5.1.6 for details).
- **Damping Value:** The smoothed output after the real-time value passes through a damping filter (see Section 6.5.1.5 for details).

- Temperature: Indicates the temperature of the signal processing board.
- Version Number: Indicates the specific product model. The model definition is shown in Figure 1-1.
- Communication Status: Heartbeat indicator of system communication status. A 1-second flash indicates normal operation. If it does not flash or flashes at long intervals, a communication fault is present.
- Unit: Indicates the measurement unit of the system. For setting details, refer to Section 6.4.2.
- Current Output: Indicates the theoretical 4 – 20mA analog output corresponding to the measured value. It is automatically calculated based on the upper/lower level adjustment points and the 4 – 20mA output function. For conversion details, refer to Sections 6.5.4 (6 – 8).
- Fault Code: Refer to Appendix A for detailed definitions.

6.3 Echo Interface Description

Table 6-2 Key Function Description in Echo Interface

Key	Function
ESC	Switch to the measurement interface
UP	Switch display unit of echo intensity (dB / amplitude value)
DN	Show/Hide threshold curve
ENT	-NULL

- Press [ESC] in the measurement interface to enter the Echo Interface.

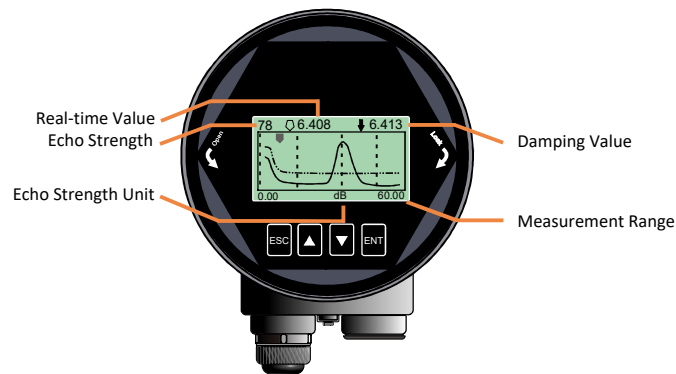

Figure 6-2 Echo Interface

In the Echo Interface, note the following:

- Echo Strength indicates the strongest echo signal within the measurement range (not necessarily the echo currently selected by the algorithm). For a good metal reflector, the echo strength should be around 70 dB. If the echo strength is below 30 dB, it indicates a weak signal, and troubleshooting by technical personnel is required.
- The Real-time Value and Damping Value in the echo interface are always measured in distance mode, meaning they represent the distance from the sensor reference point to the material level.

6.4 Settings Interface Description

Table 6-3 Key Functions in the Settings Interface

Key	Function
ESC	Enter the measurement interface
UP	Move up to select items
DN	Move down to select items
ENT	Enter the selected submenu

- From the measurement interface, press [ENT] to enter the Settings Interface, as shown below: Figure 6-3 Settings Interface



Figure 6-3 Settings Interface

6.4.1 [Basic Settings]

The [Basic Settings] menu contains the essential functional options required for normal operation of the device, as shown in the table below. Under typical working conditions, the instrument can be quickly commissioned using these parameters. Select [Basic Settings] and press [ENT] to enter the options interface. The list of options is shown in the table below:

Table 6-4 Basic Settings Menu Options

Default Position	Menu Item
●	Tank Type
	Medium Type
	Low Level Adjustment
	High Level Adjustment
	Damping Time
	Sensor Mode

6.4.2 [Display]

The [Display] menu allows switching of [Distance Unit], [Temperature Unit], and [Display Language]. Select [Display] and press [ENT] to enter the options interface. The list of options is shown in the table below:

Table 6-5 Display Menu Options

Default Position	Main Menu Item	Submenu Item
●	Distance Unit	m, cm, mm, ft, in
	Temp Unit	°C、K
	Display Language	Chinese, English

6.4.3 [Diagnostics]

The **[Diagnostics]** menu provides statistical analysis of current and historical data, helping to summarize and evaluate on-site operating conditions. Select **[Diagnostics]** and press **[ENT]** to enter the options interface. The list of options is shown in the table below:

Table 6-6 Diagnostics Menu Options

Default Position	Menu Item
●	Historical Measurement Peak
	Historical Temperature Peak
	Historical Inlet Rate
	Historical Outlet Rate
	Echo Curve
	History Time
	Historical Curve

6.4.4 [Professional Settings]

Select **[Professional Settings]** and press **[ENT]** to enter the options interface. The list of options is shown in the table below. The Professional Settings should preferably be configured by qualified personnel who are familiar with the working principles of radar.

Table 6-7 Professional Settings Menu Options

Default Position	Menu Item
●	Blind Zone Setting
	Measuring Range Setting
	Factory Reset
	Bus Address
	Distance Offset
	Current Output Function
	4mA Position
	20mA Position
	Current Calibration
	False Echo Learning
	False Echo Zone
	False Echo Mode
	Filling Rate
	Emptying Rate
	Fault Output Current
	Fault Timer

6.4.5 [Information]

Select **[Information]**, then press **[ENT]** to enter the options interface. The **[Information]** menu includes the following items, as shown in the table below:

Table 6-8 Information Menu Options

Default Position	Menu Item
●	Display Version
	Main Unit Version
	Sensor Model
	Serial Number
	Sensor Tag

6.5 Menu Operation Instructions

6.5.1 Basic Settings Menu Description

Through the basic settings, the instrument can be quickly started. After powering on, the display enters the measurement interface. Press the **[ENT]** key to access the **[Basic Settings]** menu. Unless otherwise specified, items marked with * indicate default settings.

6.5.1.1 [Container Type]

Enter the **[Basic Settings]** menu, select **[Container Type]**, and press the **[ENT]** key to enter the container type selection menu. By selecting different container types, the system's default parameters will be automatically adjusted as shown in the table below.

Table 6-9 Container Type Description

Parameter Name	Container Type		
	0.3–60 m	0.6–120 m	0.08–30 m
Large Capacity Silo	Filling/Emptying Rate: 0.1 m/min Damping Time: 60 s		
Medium Capacity Silo*	Filling/Emptying Rate: 1 m/min Damping Time: 10 s		
Tall & Narrow Silo	Filling/Emptying Rate: 10 m/min Damping Time: 0 s		
Small Dead Zone	Filling/Emptying Rate: 1 m/min Damping Time: 10 s		
Demo	Damping Time: 0 s		

6.5.1.2 [Medium Type / Dielectric Constant]

The medium type and dielectric constant mainly affect the selection of the echo processing algorithm and should be set according to the actual application.

Table 6-10 Medium Type Description

Solid Material	Liquid (Dielectric Constant)
Powder*	>10*
Small Bulk Solids	3–10
Large Bulk Solids	<3

6.5.1.3 [Low-Level Adjustment]

The [Low-Level Adjustment] refers to the low-level calibration point. For the specific definition, please refer to the figure below.

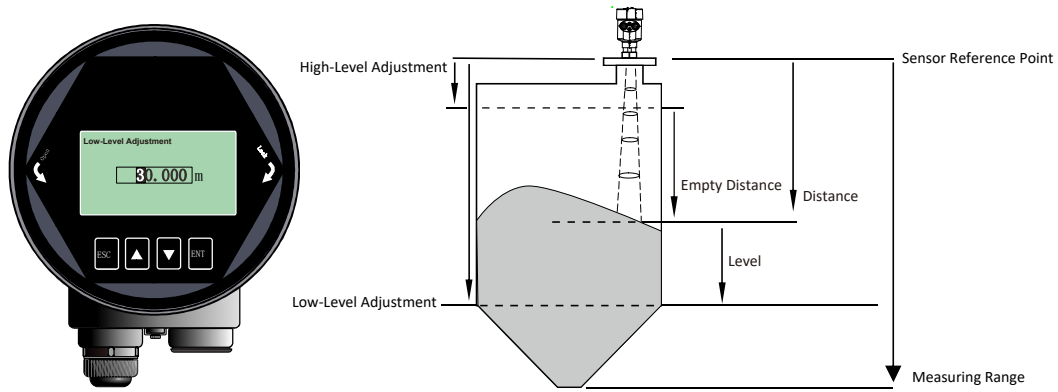

Figure 6-4 Low-Level Adjustment Editing Interface and Definition

Table 6-11 Low-Level Adjustment Description

	0.08–30 m	0.3–60 m	0.6–120 m
Parameter Name	Low-Level Adjustment		
Parameter Range (m)	1–Measuring Range		
Default Value (m)	30	60	120
Related Configuration	<ol style="list-style-type: none"> 1. If the set Low-Level Adjustment < High-Level Adjustment + 0.1, then Low-Level Adjustment = (High-Level Adjustment + 0.1); 2. When the current output function is Level, changing the Low-Level Adjustment will automatically change the 4mA position; 3. When the current output function is Empty Distance, changing the Low-Level Adjustment will automatically change the 20mA position; 		
Option Description	<ol style="list-style-type: none"> 1. When the current output function is Level, the Low-Level Adjustment point corresponds to the 4mA position; 2. When the current output function is Empty Distance, the Low-Level Adjustment point corresponds to the 20mA position; 		
Notes	The Low-Level Adjustment point is independent of the measuring range and only affects level calculation and analog (current) output value.		

6.5.1.4 [High-Level Adjustment]

The **[High-Level Adjustment]** refers to the high-level calibration point. For the specific meaning, please refer to Figure 6-4.



Figure 6-5 High-Level Adjustment Editing Interface

Table 6-12 High-Level Adjustment Description

	0.08–30 m	0.3–60 m	0.6–120 m
Parameter Name	High-Level Adjustment		
Parameter Range (m)	0–(Low-Level Adjustment – 0.1)		
Default Value (m)	0	0	0

Related Configuration	<ol style="list-style-type: none"> If the set High-Level Adjustment > (Low-Level Adjustment - 0.1), then the High-Level Adjustment will be set to (Low-Level Adjustment - 0.1); When the current output function is Empty Distance, changing the High-Level Adjustment will automatically change the 4mA position; When the current output function is Level, changing the High-Level Adjustment will automatically change the 20mA position;
Option Description	When the current output function is Empty Distance, the High-Level Adjustment corresponds to the 4mA position; When the current output function is Level, the High-Level Adjustment corresponds to the 20mA position.
Notes	The High-Level Adjustment is independent of the blind zone setting and only affects the calculation of empty distance and the analog (current) output value.

6.5.1.5 [Damping Time]

The purpose of **[Damping Time]** is to smooth sudden changes in the measured results, acting as a damping filter. For example, if the damping time is set to 2 seconds, when the position of the measured object changes in a step at time t, the measured output value will change gradually. Within the first 2 seconds, 63.2% of the change is completed, and it will follow the actual position after 10 seconds (5 times the set value), as shown in the figure below.

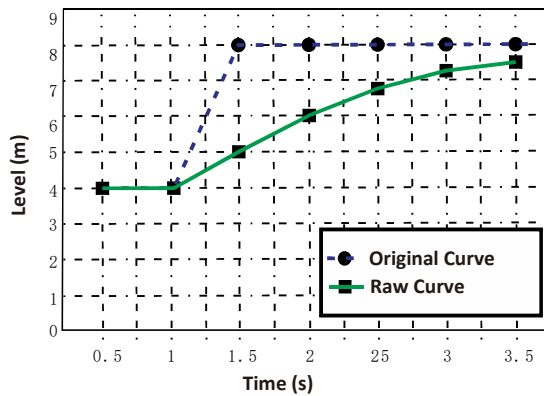

Figure 6-6 Damping Time Editing Interface and Description

Table 6-13 Damping Time Description

	0.08–30 m	0.3–60 m	0.6–120 m
Parameter Name	Damping Time		
Parameter Range (S)	0–600 (display & control unit)		
Default Value (S)	60		
Related Configuration	None		
Option Description	Damping output to improve signal stability		
Notes	None		

6.5.1.6 [Sensor Mode]

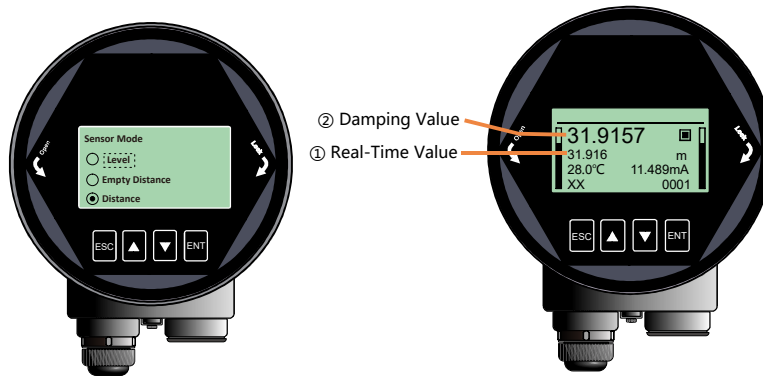

Figure 6-7 Sensor Mode Editing Interface

The **[Sensor Mode]** allows the user to select how distance information is displayed on the measurement interface according to on-site requirements. The core parameter is the measured distance from the sensor reference point to the material level. Table 6-14 provides the specific calculation formula for the real-time value.

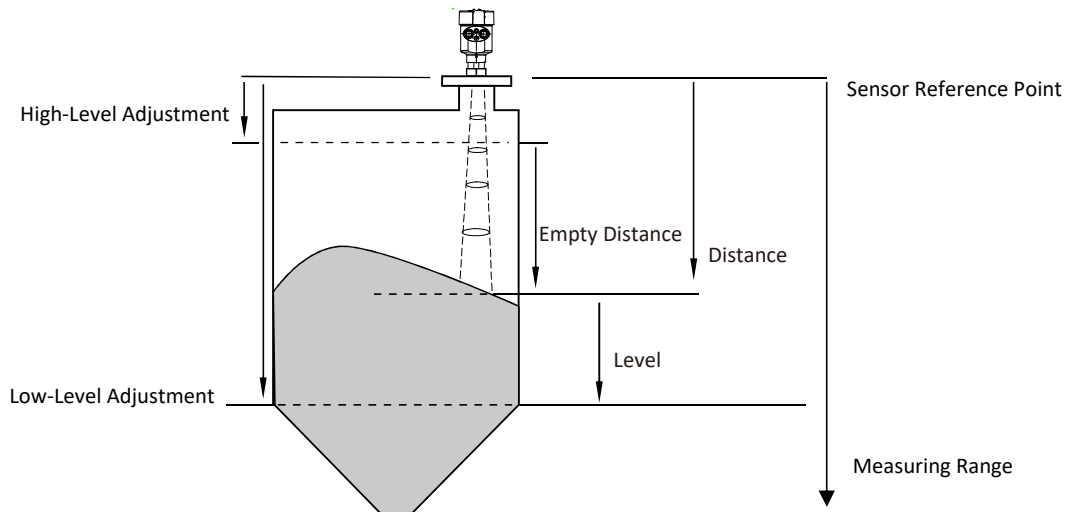

Figure 6-8 Parameter Description

Table 6-14 Sensor Mode Description

	0.08–30 m	0.3–60 m	0.6–120 m
Parameter Name	Sensor Mode		
Default Value	Distance		
Related Configuration	None		
Option Description	Distance Mode: Real-time value = Distance Level Mode: Real-time value = Low-Level Empty Distance Mode: Real-time value = Distance – High-Level Adjustment (minimum value is 0)		
Notes	If Distance > Low-Level Adjustment, then Level = 0; If Distance < High-Level Adjustment, then Empty Distance = 0.		

6.5.2 Display Menu Operation Instructions

6.5.2.1 [Distance Unit]

The **[Distance Unit]** determines the unit of the real-time value and damping value on the measurement interface. The default unit is m. Enter the **[Display]** menu, select **[Distance Unit]**, and the interface will be shown as follows:

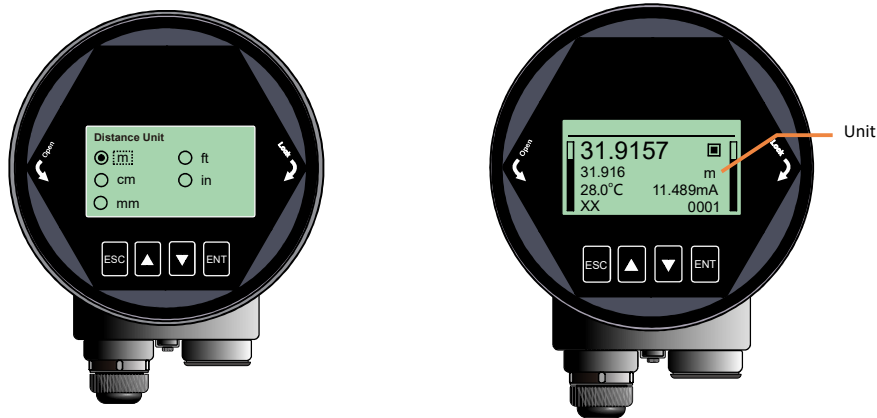

Figure 6-9 Distance Unit Editing Interface

6.5.2.2 [Temperature Unit]

The **[Temperature Unit]** determines the unit used to display temperature on the measurement interface. The default unit is °C. Enter the **[Display]** menu, select **[Temperature Unit]**, and the interface will be shown as follows:

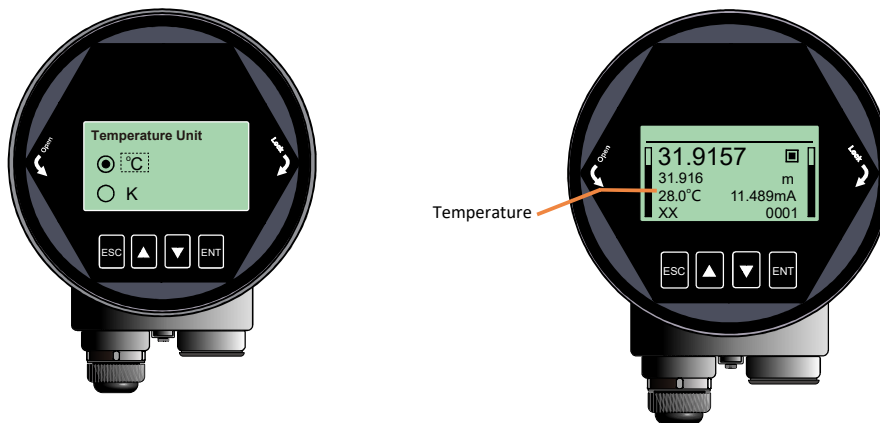

Figure 6-10 Temperature Unit Editing Interface

6.5.2.3 [Display Language]

The **[Display Language]** determines the language used across all interfaces to suit users in different countries. Currently, both Chinese and English are supported, with Chinese as the default. Enter the **[Display]** menu, select **[Display Language]**, and the interface will be shown as follows:

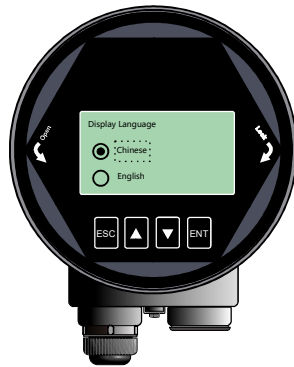

Figure 6-11 Display Language Editing Interface

6.5.3 Diagnostic Menu Operation Instructions

6.5.3.1 [Historical Measurement Peak Value]

The [Historical Measurement Peak Value] is used to record the maximum and minimum measured values since the device left the factory. The measured values refer to the analog outputs (Level, Distance, Empty Distance). Enter the [Diagnostic] menu, select [Historical Measurement Peak Value], and choose [Read] to view the historical minimum and maximum values. Select [Clean] to clear the historical statistics. After clearing, all previous records will be deleted and the system will restart statistics. The interface is shown as follows:



Figure 6-12 Historical Measurement Peak Value Display Interface

6.5.3.2 [Historical Temperature Peak Value]

The [Historical Temperature Peak Value] records the maximum and minimum operating temperature of the core circuit board since the device left the factory. The operation method is the same as that described in [Historical Measurement Peak Value].

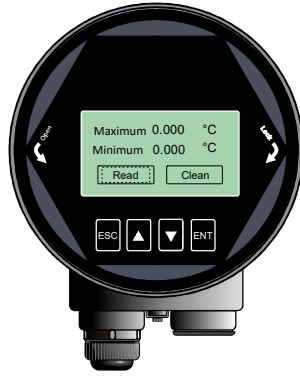

Figure 6-13 Historical Temperature Peak Value Display Interface

6.5.3.3 [Historical Filling Rate]

The **[Historical Filling Rate]** records the maximum and minimum filling rate since the device left the factory. The operation method is the same as described in **[Historical Measurement Peak Value]**.



Figure 6-14 Historical Filling Rate Display Interface

6.5.3.4 [Historical Emptying Rate]

The display of **[Historical Emptying Rate]** is shown below. Its meaning is the opposite of **[Historical Filling Rate]**.



Figure 6-15 Historical Emptying Rate Display Interface

6.5.3.5 [Echo Curve]

See “Echo Curve Interface Description”.

6.5.3.6 [Historical Time]

This option is used to set the historical time range displayed in the **[Historical Curve]** interface. The display is shown as follows:



Figure 6-16 Historical Time Editing Interface

Note: The time setting range is even numbers between 2 and 360, in hours.

6.5.3.7 [Historical Curve]

The **[Historical Curve]** records sensor measurement values according to the current sensor mode and plots a curve based on statistics within the **[Historical Time]** range. The display is shown as follows:

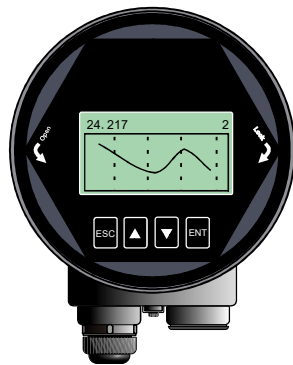

Figure 6-17 Historical Curve Display Interface

Note: Data on the right represents newer measurements. The number in the upper-left corner indicates the historical maximum measured value, while the number in the upper-right corner indicates the set **[Historical Time]**. The maximum statistical period is 360 hours, i.e., 15 days.

6.5.4 Professional Settings Menu Operation Instructions

6.5.4.1 [Blind Zone Setting]

Enter the [Professional Settings] menu, select [Blind Zone Setting], and press the [ENT] key to enter the blind zone range editing interface. The display is shown in the figure below. The specific meaning is described in the table below.

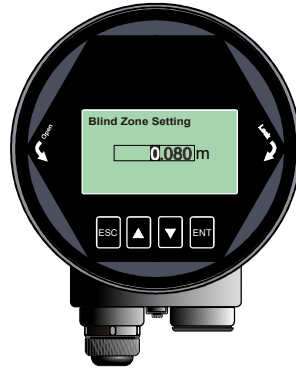

Figure 6-18 Blind Zone Setting Editing Interface

Table 6-15 Blind Zone Description

	0.3–60 m	0.08–30 m	0.6–120 m
Parameter Name	Blind Zone		
Parameter Range (m)	0–(Measuring Range - 0.1)		
Default Value (m)	0		
Related Configuration	If the set blind zone > (measuring range – 0.1), the blind zone will be set to (measuring range – 0.1).		
Option Description	During algorithm processing, echoes within the blind zone will be ignored. This option can be used to avoid interference signals from the near range.		
Notes	This blind zone does not refer to the instrument’s near-end measuring limit; it is only used to define the algorithm processing area. For the instrument’s actual measuring limits, please refer to the Technical Specifications section.		

6.5.4.2 [Measuring Range Setting]

To obtain correct measurement results, the instrument’s measuring range must be configured properly. The specific meaning is shown in the table below.

Figure 6-19 Measuring Range Setting Editing Interface



Figure 6-19 Measuring Range Setting Editing Interface

Table 6–16 Range Explanation

	0.3–60 m	0.08–30 m	0.6–120 m
Parameter Name	Measuring Range		
Parameter Range (m)	1–60	1–30	1–120
Default Value (m)	60	30	120
Related Configuration	1. If the set measuring range < (Blind Zone + 0.1), the measuring range will automatically be set to (Blind Zone + 0.1). 2. When the current output function is Distance, changing the measuring range will automatically update the value corresponding to 4mA.		
Option Description	During algorithm processing, echoes outside the measuring range will be ignored. Properly setting the measuring range can help avoid multiple reflection interference as well as interference signals outside the valid range.		
Notes	This measuring range does not refer to the instrument’s far-end measurement limit; it is only used to define the algorithm processing area. For the instrument’s actual measurement limits, please refer to the Technical Specifications section.		

Note: The blind zone and measuring range determine the effective application scope of the algorithm. Proper configuration can help avoid interference and false echoes, achieving fast and stable measurement.

6.5.4.3 [Factory Reset]

This function is used to restore the instrument to factory settings. The reset process takes approximately 15–20 seconds. The system returns to the measurement interface automatically after factory reset. If the instrument cannot measure properly due to incorrect operation, it is recommended to use this option first. The display is shown as follows:

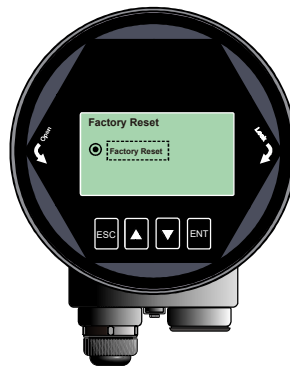

Figure 6-20 Factory Reset Interface

6.5.4.4 [Bus Address]

According to the communication protocol supported by the instrument, set the specific [Bus Address] to integrate the instrument into the field bus system. The display is shown as follows:



Figure 6-21 Bus Address Editing Interface

Table 6-17 Bus Address Description

Parameter Name	Modbus Address	HART
Parameter Range	1–247	0–15
Default Value	1	0
Related Configuration	None	
Option Description	Sets the RS485 communication address of the instrument	Sets the HART communication address of the instrument
Special Notes	The system will restart after this setting is changed	The system will restart after this setting is changed. When the HART short address is not 0, the output current is fixed at 4mA

6.5.4.5 [Distance Offset]

The **[Distance Offset]** is used to correct the sensor reference point. The interface is shown in the figure below. The instrument’s default reference point is factory calibrated to the position shown as point a in the figure below. If the reference point needs to be adjusted downward to point b, enter h1 in the setting.

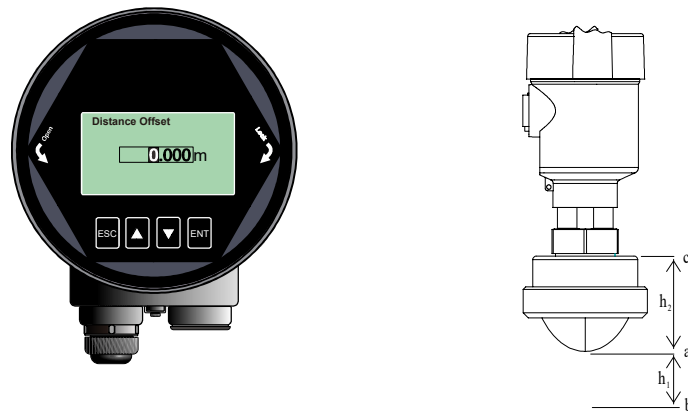

Figure 6–22 Distance Offset Editing Interface

Table 6–18 Distance Offset Description

	0.3–60 m	0.08–30 m	0.6–120 m
Parameter Name	Distance Offset		
Parameter Range (m)	(-Built-in offset)–10		
Default Value (m)	0		
Related Configuration	None		
Option Description	Used to correct the sensor reference point. The output range of the sensor remains between [Blind Zone] and [Measuring Range]. The actual measurement range is normalized based on the initial reference point: [Distance Offset + Blind Zone] – [Distance Offset + Measuring Range]		
Notes			

6.5.4.6 [Current Output Function]

The **[Current Output Function]** determines the 4–20mA output current on the bus. Based on the real-time value, the current output function, and the 4mA / 20mA positions, the theoretical loop current output value is calculated through linear conversion, and the circuit outputs the corresponding current on the bus.

The interface is shown as follows:

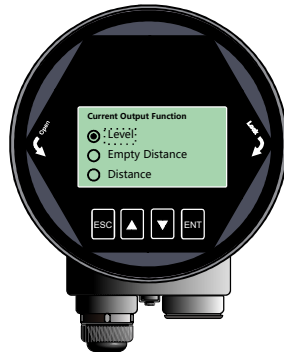

Figure 6-23 Current Output Function Editing Interface

Under different options, the relationship between the 4mA position, 20mA position, Low-Level Adjustment, and High-Level Adjustment is shown in the figure below:

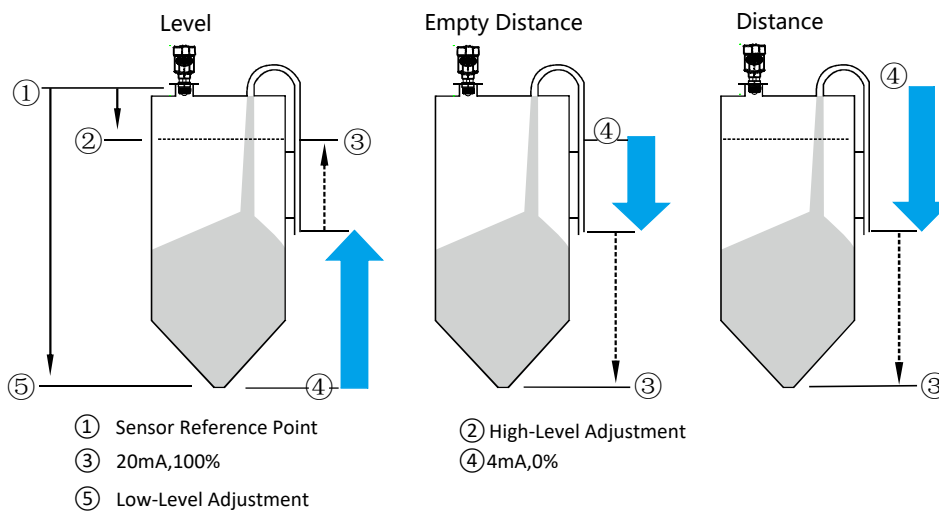

Figure 6-24 Schematic Diagram of Current Output Function Table 6-19

Current Output Function Description

	0.3-60 m	0.08-30 m	0.6-120 m
Parameter Name	Current Output Function		
Default Value (m)	Level		
Related Configuration	4mA Position Summary: When the current output function is Distance, the 4mA position = 0 m; When the current output function is Level, the 4mA position = Low-Level Adjustment; When the current output function is Empty Distance, the 4mA position = High-Level Adjustment; 20mA Position Summary: When the current output function is Distance, the 20mA position = Measuring Range; When the current output function is Level, the 20mA position = High-Level Adjustment; When the current output function is Empty Distance, the 20mA position = Low-Level Adjustment;		
Option Description	Analog Output Configuration Method		
Notes	The above "Related Configuration" refers to the system's default corresponding relationship. Changing the 4mA/20mA positions individually will modify the default settings.		

6.5.4.7 [4mA Position]

The [4mA Position] represents the 0% point of the analog output. Users can customize the 4mA position according to actual requirements. This setting has higher priority than the default relationship defined by the current output function. The interface is shown as follows:



Figure 6-25 4mA Position Editing Interface

6.5.4.8 [20mA Position]

The meaning of the [20mA Position] is described in the [4mA Position] section. The interface is shown as follows:



Figure 6-26 20mA Position Editing Interface

6.5.4.9 [Current Simulation]

The [Current Simulation] function forces the loop current to output a fixed value. It is used to verify whether the 4–20mA output circuit is operating correctly without abnormalities. The interface is shown as follows:

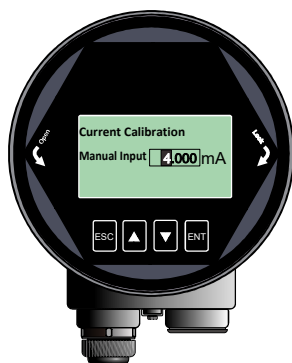

Figure 6-27 Current Output Function Editing Interface

Table 6–21 Manual Input Value Description

	0.3–60 m	0.08–30 m	0.6–120 m
Parameter Name	Current Simulation		
Parameter Range (mA)	4–20		
Default Value (m)	4		
Related Configuration			
Option Description	Manually set the current output value to check whether the 4-20mA output loop current is accurate and free from abnormalities.		
Notes	Usage steps: <ol style="list-style-type: none"> 1. On the interface shown in Figure 6-27, set the custom current value. 2. Do not exit the [Current Simulation] interface. At this time, use an ammeter to measure the current value at the corresponding 4-20mA output terminals. 3. After completing the measurement, exit the [Current Simulation] interface. The system will then return to normal analog output operation. 		

6.5.4.10 [False Echo Learning]

The **[False Echo Learning]** function is used to learn false echoes from containers with known obstructions and generate a background noise suppression curve (threshold curve TVT). Before performing false echo learning, the **[False Echo Mode]** and **[False Echo Zone]** must be properly configured. For detailed operation steps, refer to Section 6.5.4.12. The menu is shown below:



Figure 6–28 False Echo Learning Interface

6.5.4.11 [False Echo Zone]

The **[False Echo Zone]** defines the range for false echo learning. This function is valid when **[False Echo Mode]** is set to “Selected Zone” or “Excluded Zone”. The interface is shown as follows:



Figure 6–29 False Echo Zone Interface

Table 6–22 Echo Zone Description

	0.3–60 m	0.08–30 m	0.6–120 m
Parameter Name	False Echo Zone		
Parameter Range (mA)	Start: 0–Measuring Range; End: (Start+0.1) – Measuring Range		
Default Value (m)	0		
Related Configuration	None		
Option Description	Set the start and end points for false echo learning or deletion.		
Notes	Valid when [False Echo Mode] is set to " Selected Zone " or " Excluded Zone ".		

6.5.4.12 [False Echo Mode]

The **[False Echo Mode]** allows selection among three modes: Full Range, Select Zone, and Exclude Zone. "Selected Zone" and "Excluded Zone" must be used together with the [False Echo Zone] setting to learn or remove false echoes in different ranges. The interface is shown as follows:

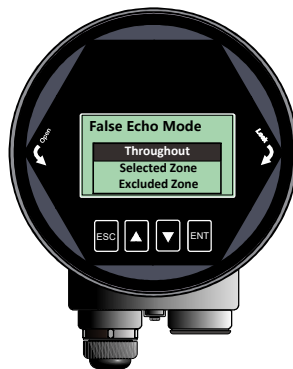

Figure 6–30 False Echo Mode Interface

Note: The default mode is "Full Range".

Example: If there is an interference signal in the range of 2 m to 4 m from the instrument, a new TVT curve needs to be created to suppress the interference. The operation steps are as follows:

- (1) Select "Selected Zone" in **[False Echo Mode]**;
- (2) Set the start value to 2 m and the end value to 4 m in **[False Echo Zone]**;
- (3) In **[False Echo Learning]**, select "New" and confirm. After the "OK" prompt appears, the TVT curve is successfully created.

The following figures illustrate the principle and effect of false echo learning. It can be seen that after learning, the false echo curve perfectly overlays the real-time measurement curve, leaving only the true material level echo visible. Users can observe this via the echo curve interface or perform more detailed analysis via the upper computer.

Before False Echo Learning

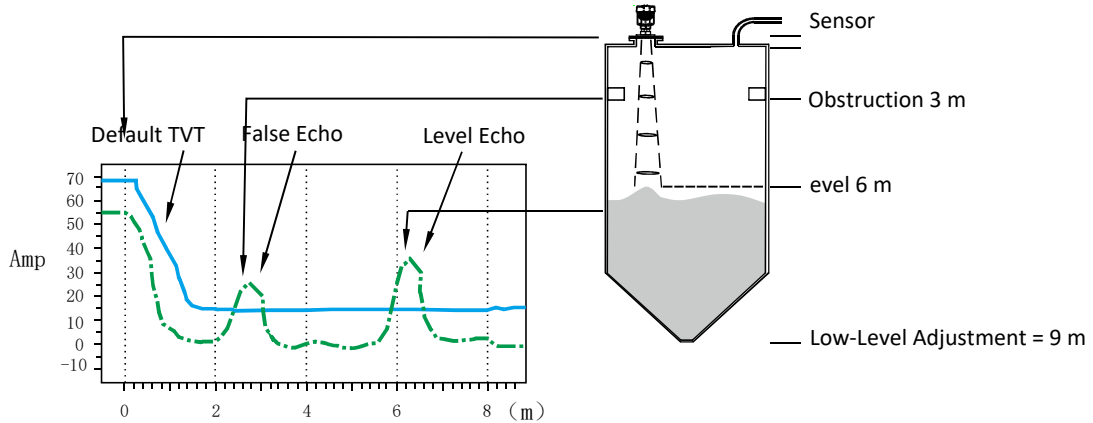

After False Echo Learning

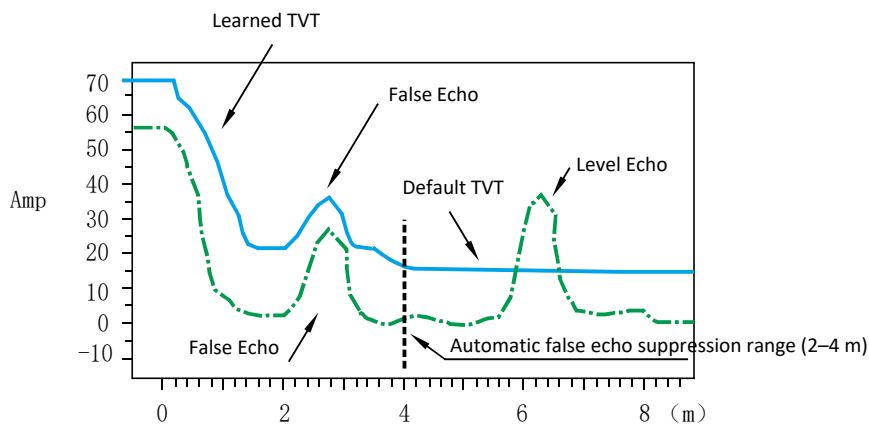

Figure 6–31 Principle of False Echo Learning

The meanings of other option combinations are shown below:

Table 6–23 False Echo Mode Description

	Full Range	Selected Zone	Excluded Zone
New	Learn false echoes over the full range (0–instrument measurement limit)	Learn false echoes within the range of 2m–4m; other zones remain unchanged	Learn false echoes over the full range except within the 2m–4m zone; false echoes in the 2m–4m zone remain unchanged
Clear	Clear false echoes over the full range	Clear false echoes within the range of 2m–4m; other zones remain unchanged	Clear false echoes over the full range except within the 2m–4m zone; the 2m–4m zone remains unchanged

6.5.4.13 [Filling Rate]

The **[Filling Rate]** is used to adjust the response speed of the instrument when the material level is increasing. When the filling rate setting is changed, the response speed is automatically adjusted.

The interface is shown as follows:



Figure 6-32 Filling Rate Editing Interface

6.5.4.14 [Emptying Rate]

The [Emptying Rate] corresponds to the [Filling Rate]. The interface is shown as follows:

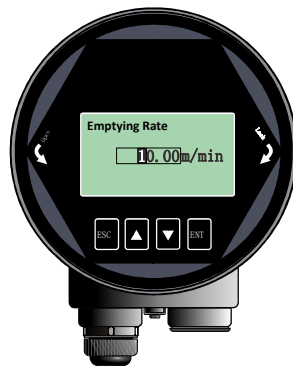

Figure 6-33 Emptying Rate Editing Interface

Table 6-24 Filling and Emptying Rate Description

	0.3-60 m	0.08-30 m	0.6-120 m
Parameter Name	Filling Rate / Emptying Rate		
Parameter Range (m/min)	0-100		
Default Value (m/min)	0.1		
Related Configuration	None		
Option Description	Set the response rate for material tracking.		
Notes	<ol style="list-style-type: none"> 1. Valid only in Tracking Mode. 2. The container type options include the system's default settings for inlet and outlet rates. The user can set appropriate inlet and outlet rates in this menu according to actual site conditions to override the instrument's default settings, enabling a more timely and accurate level response from the instrument. 		

6.5.4.15 [Fault Output Current]

The [Fault Output Current] allows setting the output current value when the instrument encounters a signal loss fault. For specific fault codes, refer to Appendix A. The interface is shown below:

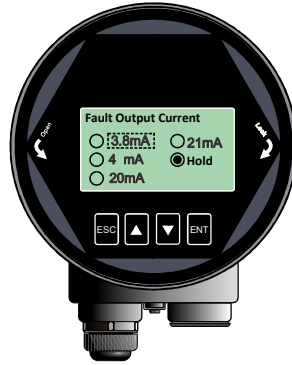

Figure 6–34 Fault Output Current Editing Interface

The “Hold” option indicates that the output will maintain the most recent valid measurement current.

6.5.4.16 [Fault Timer]

The **[Fault Timer]**, also called the signal-loss timer, defines the time duration of continuous fault or signal loss. When it exceeds the set value, the 4–20mA output will follow the value defined in **[Fault Output Current]**. The default is 100 s, with a range of 0–1000 s. Enter the **[Professional Settings]**, select **[Fault Timer]**, and the interface is shown as follows:



Figure 6–35 Signal Loss Timer Editing Interface

6.5.5 Information Menu Operation Instructions

6.5.5.1 [Display & Control Version]

The **[Display & Control Version]** refers to the firmware version of the LCD interface. The graphical interface is shown below:



Figure 6–36 Display & Control Version Interface

6.5.5.2 [Main Unit Version]

The **[Main Unit Version]** refers to the firmware version of the instrument. Select **[Main Unit Version]** and press **[ENT]** to enter. The interface is shown below: Main Unit Version



Figure 6–37 Main Unit Version Interface

6.5.5.3 [Sensor Model]

The **[Sensor Model]** indicates the product model of the instrument. Select it and press **[ENT]** to enter. The interface is shown below:

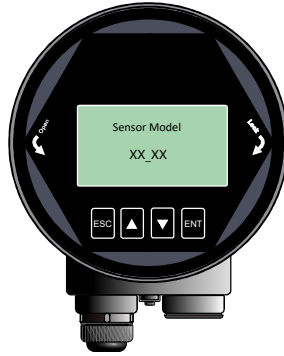

Figure 6-38 Sensor Model Interface

6.5.5.4 [Serial Number]

The [Serial Number] indicates the product serial number. Select it and press [ENT] to enter. The interface is shown below:

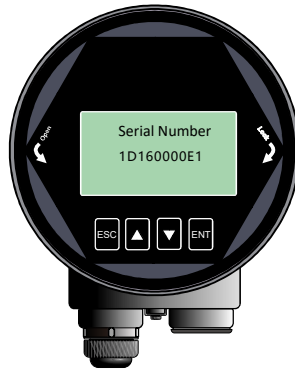

Figure 6-39 Serial Number Interface

6.5.5.5 [Sensor Tag]

The [Sensor Tag] is used for on-site identification of different sensors. It consists of 16 characters, each configurable from '0-9' or 'A-Z'. The interface is shown below:

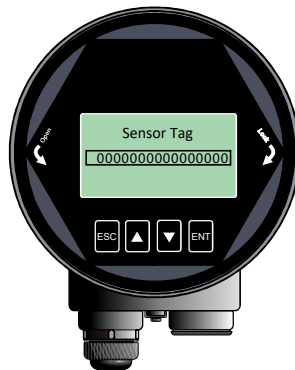

Figure 6-40 Sensor Tag Interface

6.6 Keyboard Menu Editing Operations

The operation of the numeric editing menu is described below, using Blind Zone Setting as an example:

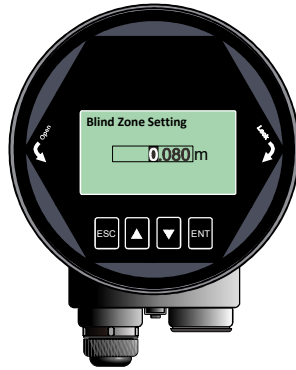

Figure 6-41 Numeric Editing Diagram

Pressing the **[DN]** key moves the cursor cyclically to the right. After moving to the last digit, the cursor returns to the leftmost position. As shown in the following figure:

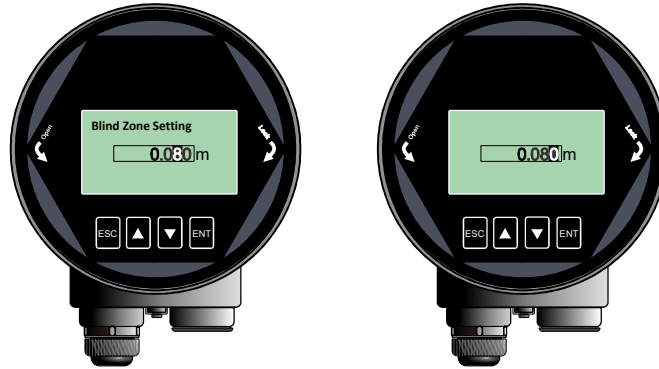

Figure 6-42 Cursor Movement with **[DN]** Key

Press the **[UP]** key to cycle the digit at the cursor position from 0 to 9.

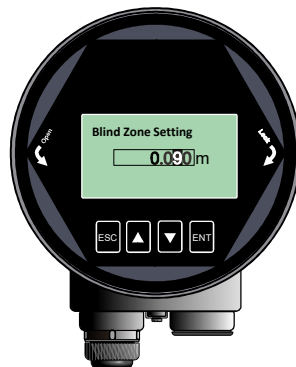

Figure 6-43 Digit Modification with **[UP]** Key

Press the **[ENT]** key to confirm the setting. The device returns to confirmation status and displays "OK" in the lower-right corner for 1 second.



Figure 6–44 Confirmation of Successful Setting

7.Menu Tree

7.1 Main Menu Tree

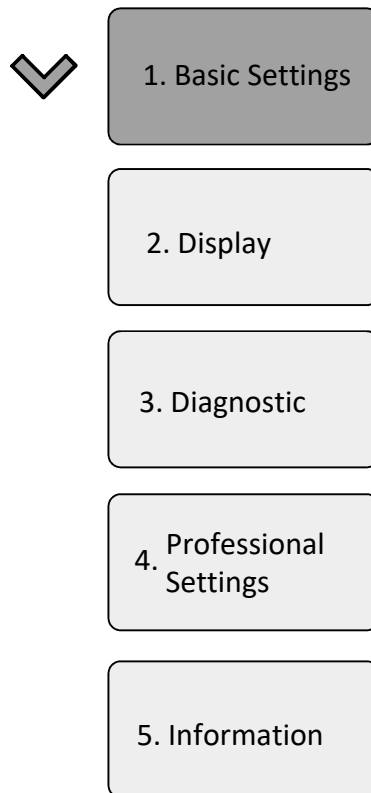

7.2 Submenu Tree – Basic Settings

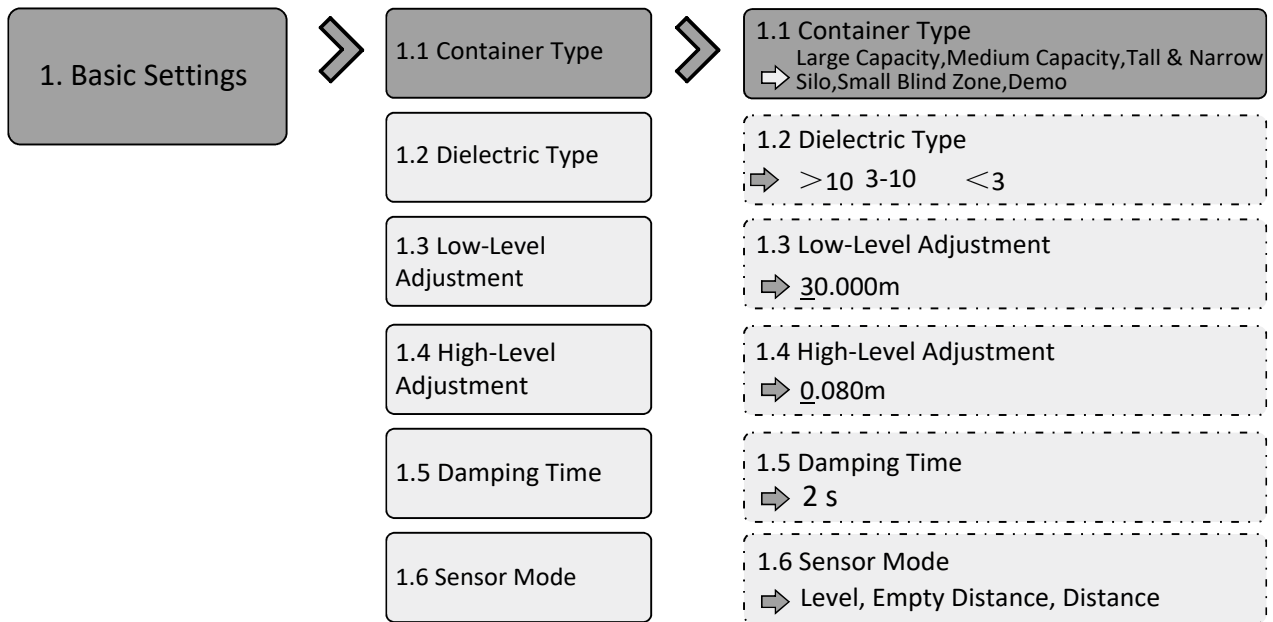

7.3 Submenu Tree – Display

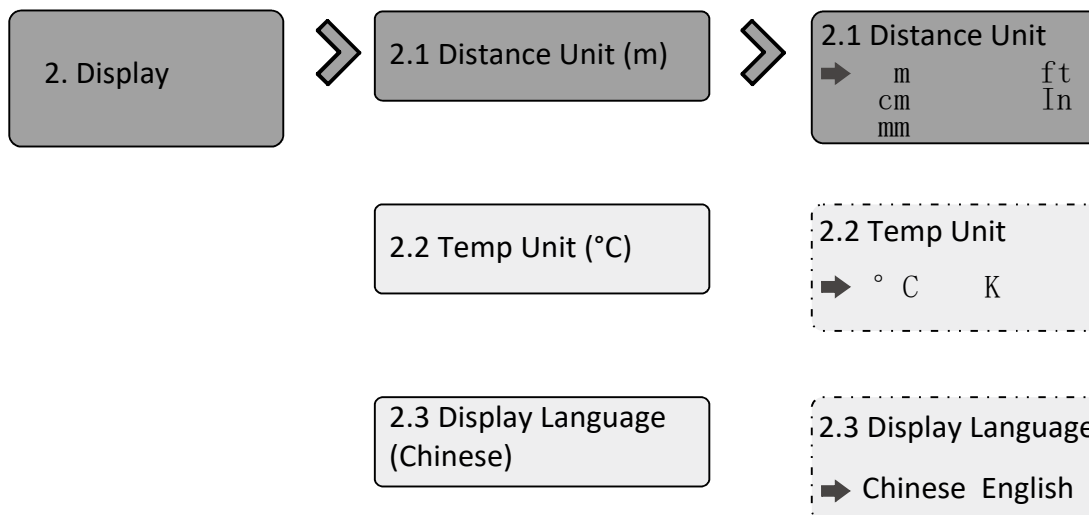

7.4 Submenu Tree – Diagnostics

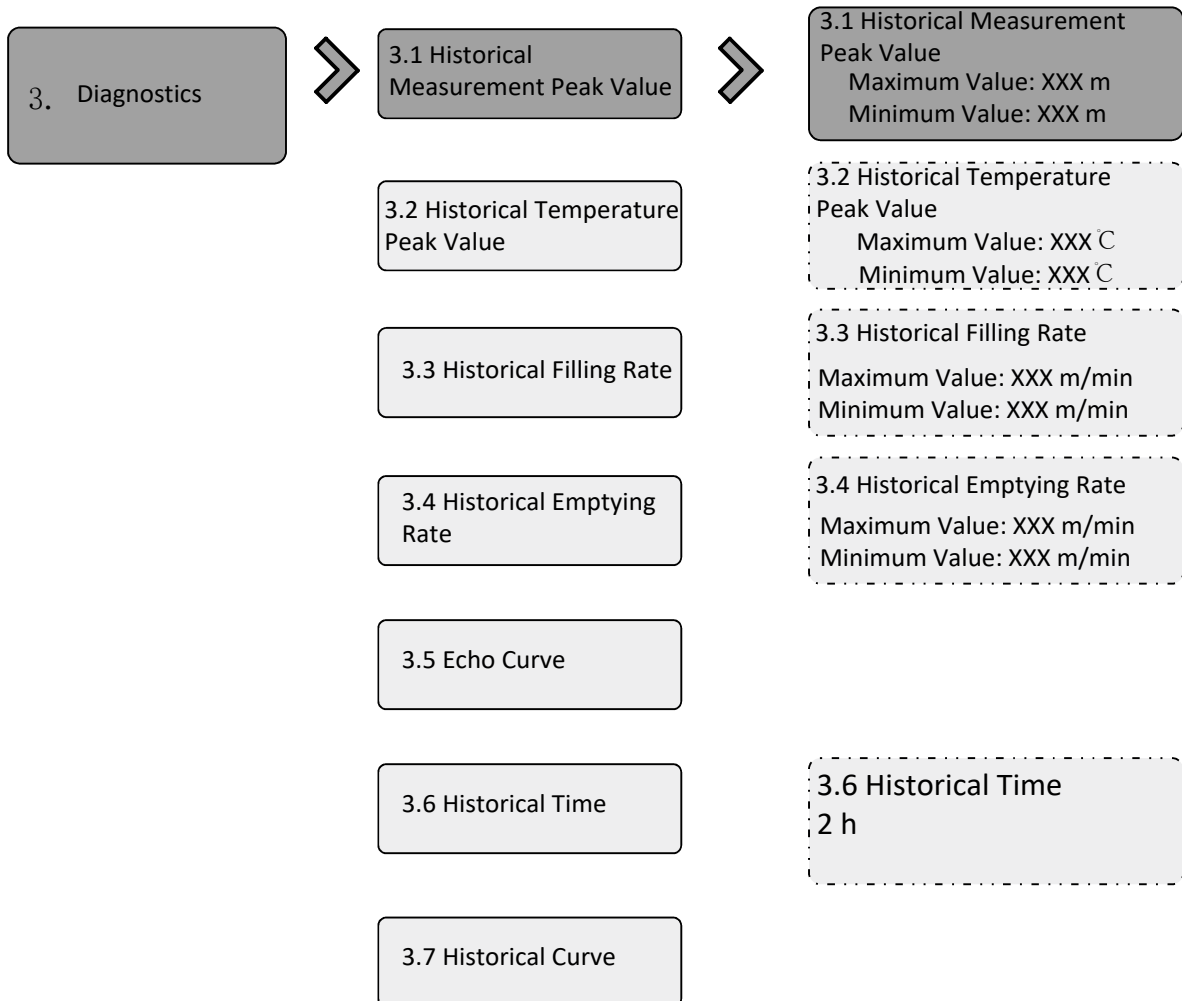

7.5 Submenu Tree – Professional Settings

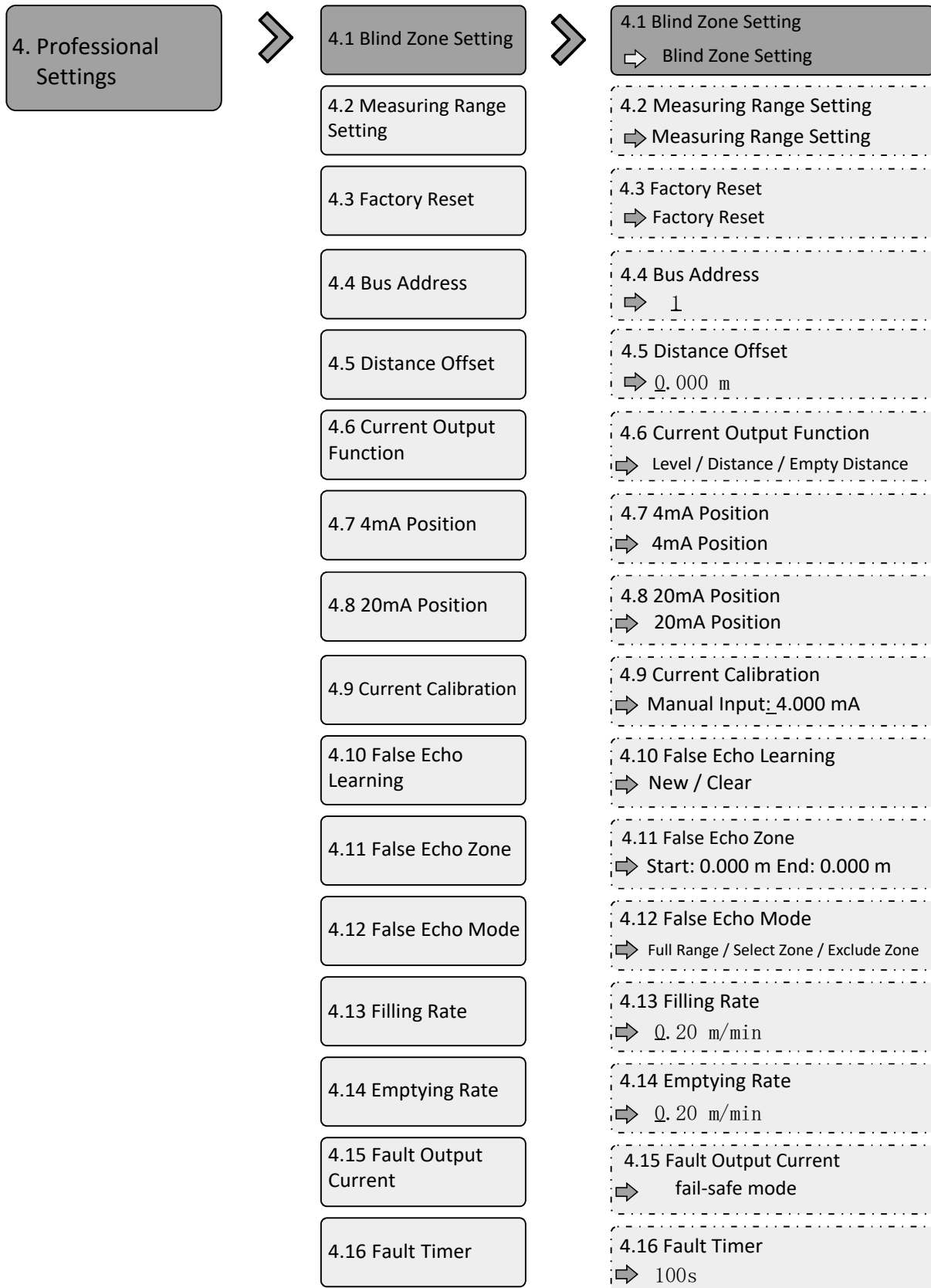

7.6 Submenu Tree – Information

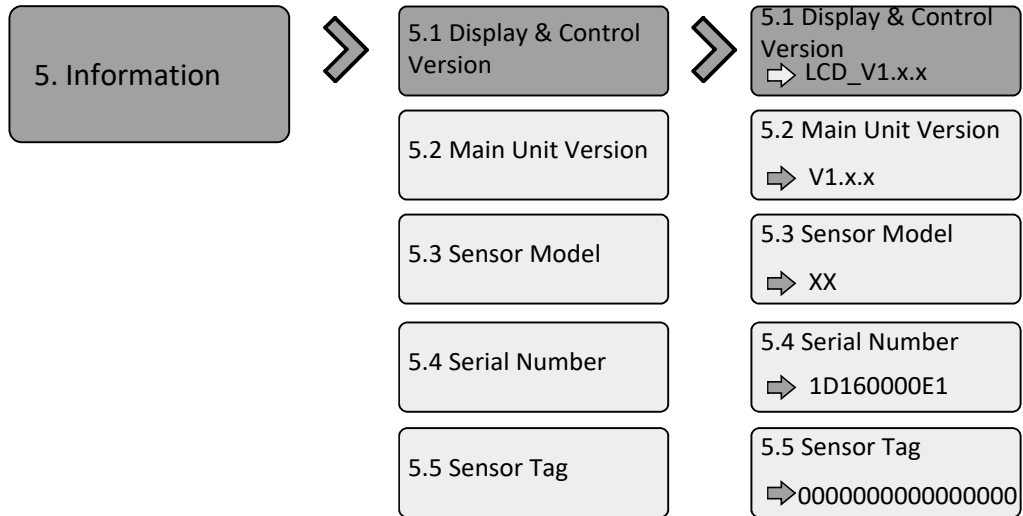

8.Troubleshooting

Symptom	Possible Cause	Corrective Action

9. Software Version History

Firmware Version	Release Date	Update Description
V1.1.9	20191019	Program optimized per modification recommendations
V1.1.17	20191203	
V1.1.24	20200212	

Display & Control Version	Release Date	Update Description
LCD_V1.1.7	20191019	
LCD_V1.1.16	20191203	
LCD_V1.1.24	20200212	

10. Appendix A: Status Codes

A status code is a 16-bit binary number (xxxxxxxxxxxxxxx) b, where each bit represents a specific error. A value of 1 indicates the corresponding error has occurred, while 0 means no error. The hexadecimal representation of the status code will be displayed on the LCD.

No.	Binary Representation	Hexadecimal Representation	Error Description
1	0000 0000 0000 0000	0000	Instrument operating normally
2	0000 0000 0000 0001	0001	No valid echo found within the given range
3	0000 0000 0000 0010	0002	Communication error with TR
4	0000 0000 0000 0100	0004	Factory threshold not learned
5	0000 0000 0000 1000	0008	4–20 mA current output abnormal
6	0000 0000 0001 0000	0010	Current manually set
7	0000 0000 0010 0000	0020	LCD communication error
8	0000 0000 0100 0000	0040	TR board connection error
9	0000 0000 1000 0000	0080	Signal processing clock error
10	0000 0001 0000 0000	0100	Processor hardware error
11	0000 0010 0000 0000	0200	Temperature sensor error
12	0000 0100 0000 0000	0400	Processor acquisition error

Multiple errors may occur simultaneously. For example, (0000 0000 0000 0011)b, which is (0003)_h in hexadecimal, indicates that errors No. 2 and No. 3 are occurring together.

11. Appendix B: Glossary

Beam Angle: The beam width defined at the -3 dB point relative to the maximum signal intensity. The minimum beam angle of the instrument is 3°, as shown in Figure 11-1.

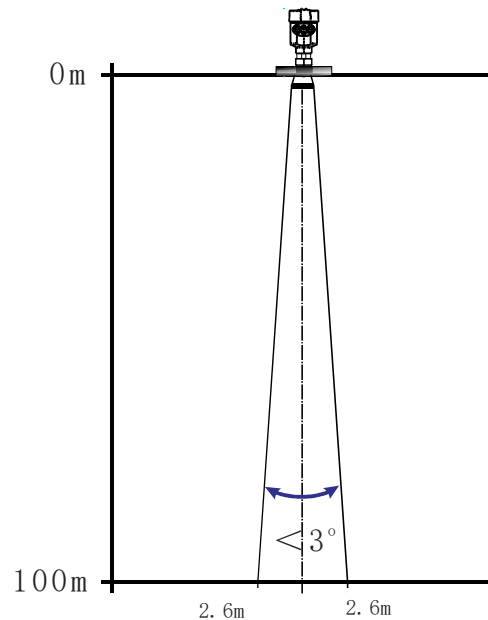

Figure 11-1 Radar Beam Geometry of the Instrument

Range Resolution: Range resolution refers to the minimum distance at which two closely spaced objects can be distinguished as separate targets by the level radar, instead of being detected as a single object, and their individual distances can be measured. If the distance between two objects is smaller than the radar's range resolution, the radar can only output one distance value. This value does not correspond to either object individually, but is a combined result of both. With a frequency modulation bandwidth of $B = 5.1 \text{ GHz}$, the minimum range resolution is calculated as: $\text{speed of light} / \text{bandwidth} / 2 \approx 3 \text{ cm}$.

Measurement Accuracy: Measurement accuracy refers to whether the level radar can detect small changes in distance when a single object moves slightly. The ability to distinguish small displacement of a single target is defined as accuracy. After internal IF signal processing and algorithm analysis, the instrument achieves a measurement accuracy of 0.7 mm.

Agitator: A mechanical device used for mixing or aeration; a device that generates turbulence.

Ambient Temperature: The temperature of the surrounding air in contact with the device housing.

Blind Zone: (1) The near-end measurement limit of the instrument. Measurements cannot be performed within the blind zone.

dB (Decibel): A unit used to express signal amplitude.

Dielectric Constant (DK): The ability of a dielectric material to store electrical energy under an electromagnetic field, often referred to as relative dielectric constant. The increase in dielectric constant is directly proportional to the increase in echo amplitude. The relative dielectric constant of vacuum/dry air is 1.

Echo: The reflected signal received by the radar.

Emission Cone: The extension of the antenna beam angle.

False Echo: Any echo that is not generated by the intended target. Generally, false echoes are caused by obstructions inside the container.

Multiple Echoes: Multiple reflected echoes appearing after the target echo distance, typically the 2nd, 3rd reflections, etc.

Polarization: A property of transmitted electromagnetic waves, describing the direction and magnitude of the electric field vector as it changes over time.

Measuring Range: (1) The far-end measurement limit of the instrument. (2) In a special sense, the maximum manually set distance beyond which the instrument does not process data.

Repeatability: The degree of deviation when measuring the same variable multiple times under identical conditions.

Speed of Light: The propagation speed of electromagnetic waves (including light in free space), approximately 299,792.458 meters per second.

Threshold Curve (TVT): A time-varying curve used as a threshold. Echoes above this curve are considered valid echoes.