

## Remote Temperature and Humidity Transmitter



### Function Overview

- High-precision and high-stability temperature and humidity sensor
- Oversized display with backlight
- Compact size, light weight, low power consumption and fast response
- Equipped with data logging function; maximum logging capacity: 12,800 points
- Supports USB and RS485 communication
- Dual power supply options: 9~36V (DC/AC)/USB 5V
- Built-in alarm function
- Built-in rechargeable lithium battery

### Accessory List

- 1 × Transmitter
- 3 × Fixing Screws
- 1 × User Manual
- 1 × USB Cable

### 1. Product Overview

The remote temperature and humidity transmitter is a high-performance industrial temperature and humidity transmitter with built-in battery and data logging function. It measures ambient temperature and humidity and displays readings digitally on the local display screen. When measured data exceeds the preset limit, the device outputs control signals and triggers an audible alarm. Meanwhile, it responds to commands sent by the host, uploads measured data to the host via the RS485 bus in data packets, and records data at the user-configured logging interval.

Featuring compact size, light weight, wide measuring range, high accuracy, fast response speed and excellent long-term stability, this temperature and humidity transmitter is widely applied in scenarios requiring precise measurement and control of ambient temperature and humidity, including building automation, HVAC signal acquisition, climate monitoring stations for museums and hotels, warehousing & logistics, medical industries, computer room temperature monitoring and other critical fields.

### 2. Product Specifications

1. Power Supply: 9~36V DC, USB 5V or built-in lithium battery
2. Display Resolution: 0.1 C / 0.1%RH
3. Operating Temperature: -20~+60 C, Accuracy: ±0.5 C
4. Operating Humidity: 0~99.9%RH, Accuracy: ±3%RH
5. Sampling Interval: external power: 2s; built-in battery power: 5s
6. Record Count: 12,800 (Max)
7. Power Consumption: external power: <20mA; lithium battery: <2mA
8. Sensitivity Drift: Temperature <0.1 C; Humidity <0.1%RH
9. Battery Endurance: ≥60 days
10. Output Signal: RS485 signal
11. Communication Protocol: Standard MODBUS RTU

### 3. Product Dimensions (mm)

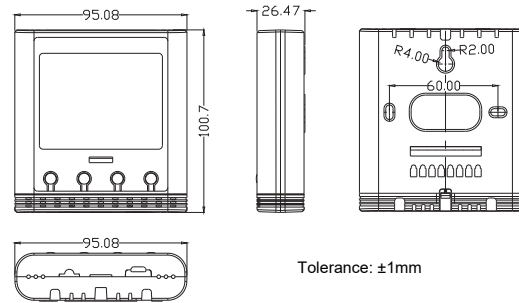

### 4. Product Installation and Wiring Instructions

#### Installation method of this product

1. Connect the four wires from the transmitter end of the 4-core (or shielded) connection cable to pins 1, 2, 3, 4 of the transmitter connector, respectively (connect the shield of the shielded cable to the power ground);
2. Connect the other end to the power supply and a computer (requires an RS485 converter) or other appropriate equipment;
3. Securely snap the front and rear casings of the transmitter together;
4. After verifying that the wiring is correct, turn on the power and check whether the transmitter's output is normal;
5. The transmitter is now ready for operation;
6. If an external alarm is required, connect it according to the RS485 typical application diagram.

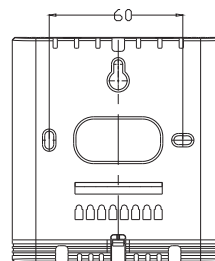

Figure 1 Fixed Hole

### Wiring instructions and typical RS485 applications

See Table 1 for wiring connection instructions.

Table 1: Wiring Connector Descriptions

No.	Label	Wiring Description	Description
1	B-	White	RS485 B terminal
2	GND	Black	Negative power input
3	V+	Red	Positive power input
4	A+	Yellow	RS485 A terminal

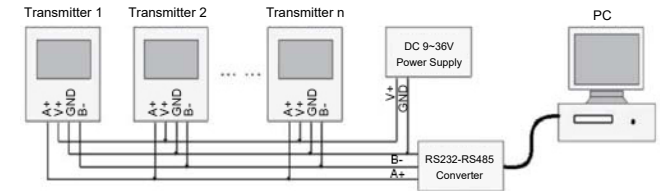

Figure 2 Typical RS485 Application

### 5. Menu and Display Instructions

#### Panel schematic description



Figure 3 Panel Illustration Explanation

#### Keyboard functions

Key	Function	Description
	Menu selection key	Switch display menu, enter the next level in multi-level menus
	Up key	In the parameter adjustment interface, execute the parameter "+"
	Down key	In the parameter adjustment interface, execute the parameter "-"
	Enter key	In the menu, execute the function of returning to the main interface or exiting the menu

#### Software power-on/off function

Display Item	Key Function	Value Range and Description	Default Value
	Instrument switch on/off	OFF/ON	OFF

**Power On/Off Function Instructions:** Press and hold the Up key to bring up the power switch interface. Select ON and press the Enter key to power off the meter. To power the meter back on, press any key; all recorded data will be preserved. (Data recording will stop after power-off).

**Reset Key Instructions:** The reset key marked with the symbol (Ⓜ) can be seen after removing the meter's rear cover. Use a toothpick or other thin, slender object to press the built-in reset key when necessary.

**Alarm Description:** The built-in alarm will sound when alarm conditions are satisfied. If you press any of these buttons while the alarm is sounding, the built-in alarm will be temporarily silenced; If the user takes no action, the built-in alarm will resume sounding after approximately 10 seconds. **Instructions for Viewing Recorded Data Points:** Press the menu selection key to enter the menu, then press the key nine times to switch to pages C.01~C.04, where the number of recorded points can be checked.

## ● Description of Function Display Items

Display Item	Key Function	Value Range and Description	Default Value
	RS485 address	1~254	001
	RS485 baud rate	1200\2400\4800\9600\19200	9600
	Alarm function	ON/OFF (Must be enabled first; the alarm function will activate only when temperature or humidity exceeds upper/lower limits)	OFF
	Temp alarm upper limit	(Low Temp Alarm Value +1) ~ 120°C	80
	Temp alarm lower limit	-40°C ~ (High Temp Alarm Value -1)°C	0.0
	Hum alarm upper limit	(Low Hum Alarm Value +1) ~ 99%RH	99.9
	Hum alarm lower limit	1 ~ (High Hum Alarm Value -1)%RH	1.0
	Temperature C/F switch	C/F	C
	Remote control switch	ON/OFF (When OFF, parameters cannot be modified via RS485 software)	ON
	Record mode	ON/OFF/AUTO	AUTO
	Storage mode	Cycle / Sequence	Sequence
	Normal recording cycle	1 min ~ 600 min	30min
	Alarm recording cycle	1 min ~ 600 min	1min
	LCD backlight switch	OFF/ON/DEL	OFF
	Backlight level	1/2/3/4/5 (1 = brightest, 5 = dimmest)	5
	Time set	Set Year, Month, Day, Hour, Minute and Second	

**Record Mode:** When record mode is set to On, the built-in automatic data recording function of the transmitter is enabled to record real-time monitoring data, which can be read via supporting software. When set to Off, the internal data recording function is disabled. When set to Auto, the intelligent recording function is activated, and data recording is controlled by the monitoring software of the system terminal. If no data recording command is received from the terminal device, the transmitter will switch back to the internal automatic recording function after 10 seconds.

**Storage Mode:** "Circular storage" refers to a mode in which, when the internal memory reaches its capacity, the system continues to store data in a repetitive manner, overwriting the previously stored data in a cyclical process; "Sequential storage" refers to a mode in which, when the internal memory reaches its capacity, the system stops storing data.

**Recording Cycle:** Time interval for recording monitoring data when measured values are within normal range.

**Alarm Recording Cycle:** Time interval for recording monitoring data when measured values exceed upper or lower alarm limits.

**Screen Backlight Switch:** Three modes: NO, NC, Delay (30s)

**Screen Backlight Level:** Five adjustable levels: 1/2/3/4/5. Level 1 is the brightest, Level 5 is the dimmest.

## 6. Examples of Communication Read Commands for Secondary Development

Note: [1] Download the complete product manual for detailed communication commands; supporting monitoring software is available for download via the designated website.

Host transmit message format: 01 03 00 00 00 02 C4 0B

The table below describes the function codes:

Master Transmission	Byte Count	Transmitted Information	Remarks
Slave address	1	01	Send to slave device with address 01
Function code	1	03	Read register
Starting address	2	0000	Starting address 0000
Number of registers read	2	0002	Read two registers totaling 4 bytes
CRC code <sup>[1]</sup>	2	C40B	CRC calculated by master, low byte (C4) transmitted first, high byte (0B) transmitted last

Format of the response message returned by the product: 01 03 04 Humidity (16-bit) Temperature (16-bit) CRC check code:

The table below shows an example of a set of temperature and humidity data returned: 01 03 04 01 D7 00 D6 CA 69

Slave Response	Byte Count	Return Data	Remarks
Slave address	1	01	From Data 01
Function code	1	03	Read Register
Return byte count	1	04	Return 4 registers with a total of 4 bytes
Register 0 high byte	1	01	Content of address 0x00 (Humidity high byte)
Register 0 low byte	1	D7	Content of address 0x00 (Humidity low byte)
Register 1 high byte	1	00	Content of address 0x00 (Temperature high byte)
Register 1 low byte	1	D6	Content of address 0x00 (Temperature low byte)
CRC code <sup>[1]</sup>	2	CA69	The CRC checksum calculated and returned by the slave transmits the low byte (CA) first

**Note:** Refer to the subsequent CRC check section for detailed calculation procedures. The CRC value needs to be recalculated if the address differs.

### ★ Temperature & Humidity Output Format

Temperature and humidity have a 16-bit resolution. They are output as actual positive and negative values, and the transmitted data is 10 times the real temperature and humidity values.

### ★ Numerical Calculations

Convert the temperature and humidity values read from the sensor to decimal via a PC calculator, then divide by 10 to get actual readings. Unit: temperature in °C, humidity in %RH.

Example of the data read above:

Humidity: 01D7 = 1 × 256 + 13 × 16 + 7 = 471 ⇒ Humidity = 471 ÷ 10 = 47.1%RH

Temperature: 00D6 = 13 × 16 + 6 = 214 ⇒ Temperature = 214 ÷ 10 = 21.4°C

### ★ CRC Calculation Method

- Pre-set one 16-bit register to hexadecimal FFFF (i.e., all 1s); call this register the CRC register;
- Perform an XOR operation between the first 8-bit binary data (i.e., the first byte of the communication information frame) and the lower 8 bits of the 16-bit CRC register, and store the result in the CRC register;
- Shift the content of the CRC register one position to the right (towards the lower bits), fill the highest bit with 0, and check the shifted-out bit;
- If the shifted-out bit is 0: Repeat step 3 (shift one more position to the right); if the shifted-out bit is 1: Perform an XOR operation between the CRC register and the polynomial A001 (10100000 0000 0001);

5. Repeat steps 3 and 4 until the data has been shifted right 8 times, thereby processing the entire 8-bit data;

6. Repeat steps 2 through 5 to process the next byte of the communication frame;

7. After calculating all bytes of the communication frame according to the above steps, swap the high and low bytes of the resulting 16-bit CRC register;

8. The final contents of the CRC register are the CRC code.

**Note:** [3] See the detailed manual for the CRC code.