

Features:

The ATO LT Series multi-tiered warning lights can be installed on various types of machinery to alert operators to unexpected situations through lights and audible alarms. Standard models and specifications can be customized to meet specific customer requirements. These lights use ultra-bright LEDs imported directly from Taiwan, with a service life exceeding 30,000 hours. A new anti-vibration design significantly reduces the risk of damage caused by severe machine vibrations. With their innovative styling and comprehensive features—including constant-on, flashing, and buzzer-equipped models—these lights are the top choice for lighting and audible alerts on all types of machinery and equipment.

Technical Specifications:

Model	Operating Voltage	Operating Current	LED Power	Incandescent Light Bulb Power	Function	Color
LT05-1 LT07-1	AC/DC12V	≤80mA	≤2W	5W	T—Constant-on Type W—Flashing Type TJ—Constant-on with Buzzer WJ—Flashing with Buzzer	Red Yellow Green Blue White
LT05-2 LT07-2	AC/DC24V	≤160mA	≤4W	10W		
LT05-3 LT07-3	AC110V	≤240mA	≤6W	15W		
LT05-4 LT07-4	AC220V	≤320mA	≤8W	20W		
LT05-5 LT07-5		≤400mA	≤10W	25W		

Installation Dimensions:

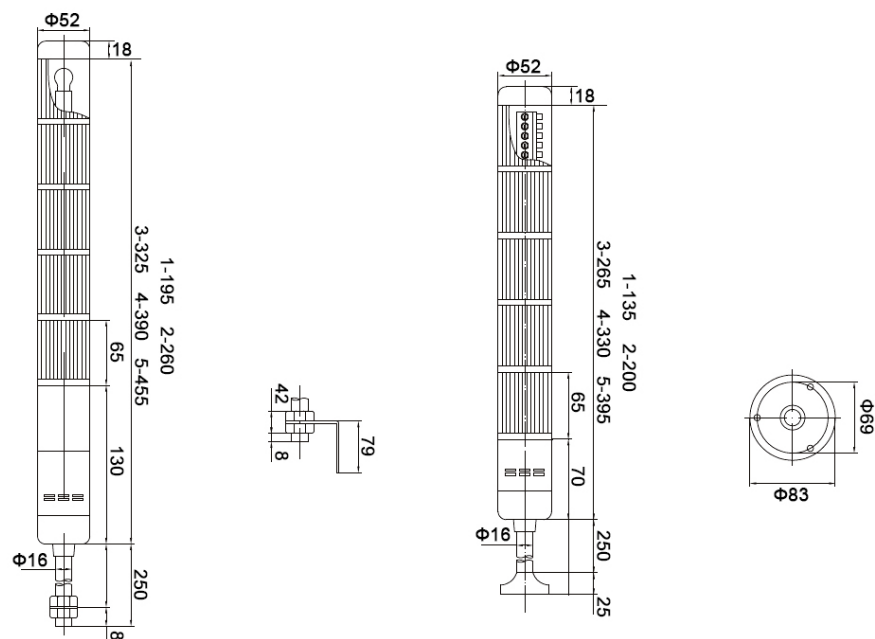

Wiring Diagram:

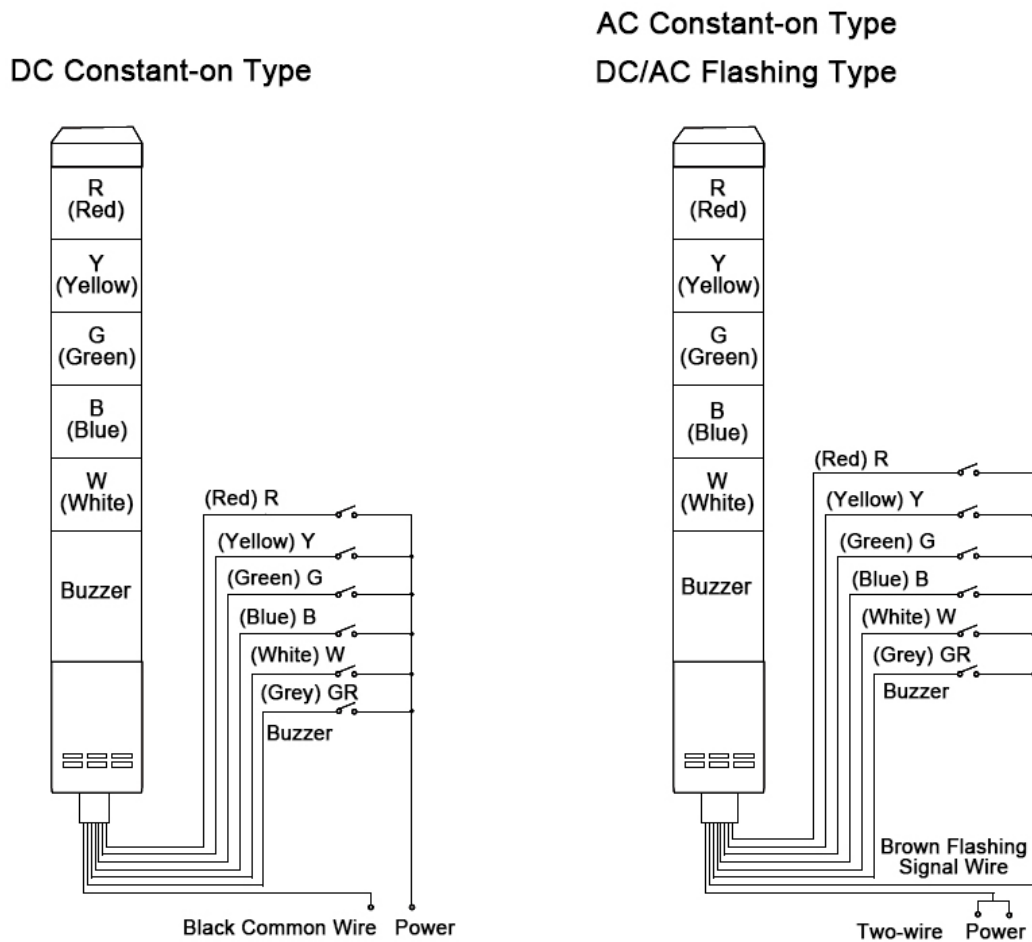

Packing List:

Warning Light	1 piece
Instruction Manual	1 serving
Certificate of Conformity	1 serving
Mounting Rod	1 piece

Important Notes: ▲

1. Be sure to disconnect the power supply before installation or maintenance.
2. The power supply voltage must match the product's rated voltage; products with different voltage ratings must not be used interchangeably!
3. Thank you for purchasing a product from ATO Store. To ensure safe and long-term use of this product, please read the user manual carefully before installation!