



U02 Fuel level sensor

TABLE OF CONTENTS



1	Product Description.....	1
	General	1
	Features	1
	Applications	1
2	Module Specification.....	2
	Operating specification	2
	Environment	2
	Electronics	3
3	Sensor Selection Instruction.....	3
4	Reliable Testing Condition.....	4
5	Notice.....	4
6	Mechanics.....	5
	Mechanical Dimensions	5
	Parts Description.....	6

Product Description

1. General

U02 fuel level sensor that uses ultrasonic detection technology to measure the height of oil and liquid substances. It's a non-contact liquid level measurement instrument. Compared with traditional detection equipment, U02 oil level has high measurement accuracy and is easy to use. It can be installed externally (without destroying the container structure) and can be connected to networked equipment to realize network monitoring and management. Ultrasonic fuel level monitoring sensor is designed to optimize the mode of vehicle monitoring. It can adapt to vehicles running or stationary at various road speeds, and can also output more stable data for other liquids loaded on the vehicle.

2. Features

- Non-contact measurement, no need to change the shape of the container, no need to polish the surface paint of the container.
- Metal shell, internal circuit potting treatment, waterproof design.
- External waterproof 3M glue, and equipped with a special metal fixing bracket, simple installation and firm fixation.
- Wide voltage operation, DC 12~48V power supply, suitable for various vehicles.
- RS232/RS485/0~5V voltage analog quantity/TTL-UART multiple output interfaces, compatible with the connection of various sensor signal acquisition equipment.
- High frequency ultrasonic detection, high solid penetration, suitable for containers of various materials such as metal and plastic.
- High stability measurement output, built-in anti-interference data processing model, intelligent filtering and compensation of environmental interference.
- High-precision measurement output, built-in high-precision calculation model, millimeter-level measurement resolution.

3. Applications

Vehicle fuel tank fuel level monitoring.

Liquid level measurement in liquid storage tank.

Container water level monitoring.

Filling liquid gas measurement.

Module specification

1. Operating specification

Item	Specification	Unit	Remark
Operating voltage	12~48	V	DC
Average operating current	≤25	mA	(1)
Measuring range	50~1000	mm	(2)
Accuracy	≤5	mm	(2)
Resolution	≤1	mm	
Beam angle	2~4°		(3)
Measurable container thickness	0.6~5.0	mm	(4)

Remark:

(1) The higher the power supply, the lower the current.

(2) Normal temperature and humidity, 1 standard atmospheric pressure, the measuring liquid is 0# diesel, other liquids need to be explained when ordering;

(3) The target container has a wall thickness of 2mm, a steel material, and a diesel fuel content of 50-100cm. Changing the tilt angle of the container can be tested.

(4) The measurement distance is affected by the material and thickness of the container. For special materials or test thicknesses greater than 5.0mm, it needs to be stated when ordering.

2. Environment

Item	Minimum value	Typical value	Max value	Unit	Remark
Storage Temp	-25	25	80	°C	

Storage Humidity		65%	90%	RH	(1)
Operating Temp	-15	25	60	°C	
Operating Humidity		65%	80%	RH	(2)

Remark:

- (1) Environment temperature is 0-39°C, max humidity is 90%(Non-condensation)
- (2) Environment is 40-50°C, max humidity is the highest at current temperature in nature.

3.Electronics

Item	Minimum value	Typical value	Max value	Unit	Remark
Operating voltage	10	24	48	V	
Peak current	150		500	mA	Peak value
Input Ripple			200	mV	Peak value
Input Noise			500	mV	Peak value
ESD			±4K/±8K	V	(2)

The probe shell and output pin comply with the IEC61000-4-2 standard.

Sensor Selection instruction

The sensor output interface has RS232, RS485, 0~5V voltage analog quantity (compatible with TTL-UART), and the user can choose the corresponding model according to the actual needs. The output interface corresponding to the sensor model is selected before leaving the factory.

No.	Model No.	Output Interface
1	DYP-U022M2W-V1.0	RS232
2	DYP-U022M4W-V1.0	RS485
3	DYP-U022MVW-V1.1	0-5V analog voltage/TTL-UART

Reliable testing Instruction

No.	Description	Testing condition	sample QTY	remark
1	High temperature and humidity	65°C, 85%RH, Power ON@5V, 72hrs	3	
2	low temperature	-20°C, Power ON@5V,72hrs	3	
3	High temperature and humidity storage	80°C, 80%RH, storage, 72hrs	3	
4	Low temperature storage	-30°C, storage, 72hrs	3	
5	Vibration test	10-200Hz,15min,2.0G, XYZ three axes, each axis is 0.5 hours	3	
6	Drop test	50 cm free fall, 5 times on wooden floor	3	

Note: After the test, the module is determined to be OK after the function test, and the performance degradation rate is $\leq 10\%$.

Notice

1. Default wire cable is 8 meters(1meter of sensor + 7 meters extended cable), If need to modify the size and length of the wire, please contact our after sale department.
2. When installing, ensure that the vehicle is parked on a flat road, and the height of the liquid level in the fuel tank is $\geq 20\text{cm}$.
3. When installing the ultrasonic sensor, you need to follow the installation instructions.
4. After refueling, the height change of the liquid level must be greater than 30mm, otherwise the oil level value will not be updated.
5. Test the alarm function, it takes one minute after power-on to be effective.

Mechanics

1. Mechanical Dimensions(mm-inch)

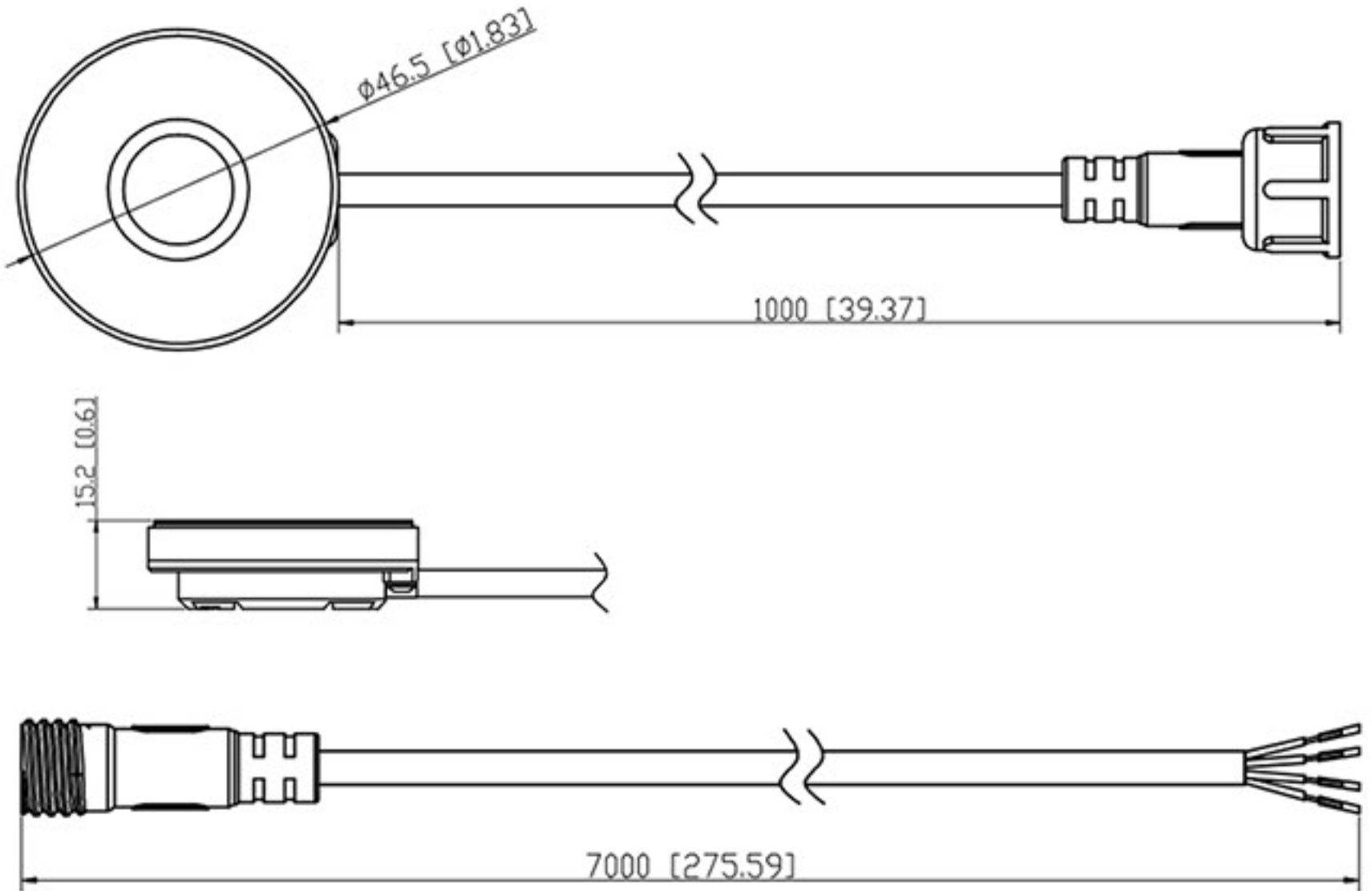

2. Parts Description

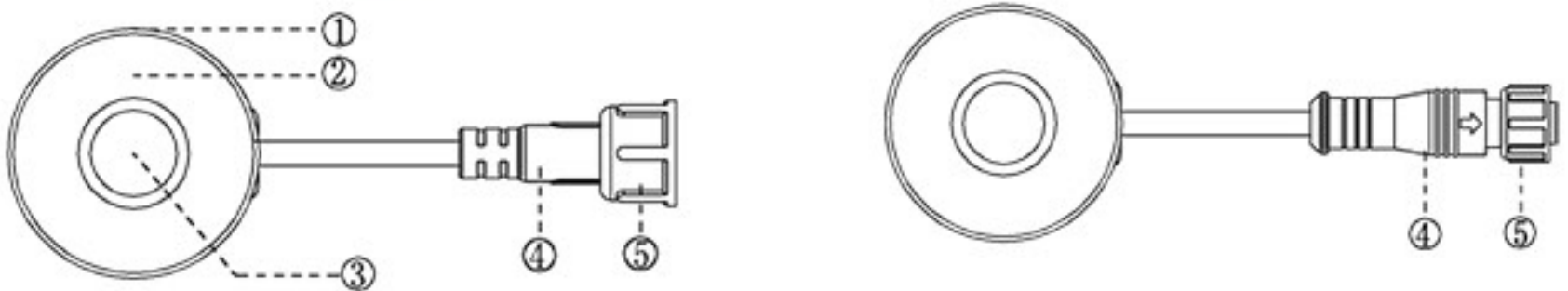

Pic 1 Sensor front view

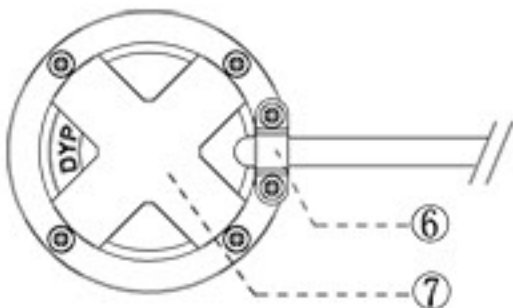

Picture 2 sensor back view

- ① The alloy case.
- ② Strong waterproof adhesive tape.
- ③ Ultrasonic transducer.
- ④ Sensor output connector.
- ⑤ The sensor connector fixing cap..
- ⑥ Sensor output wire fixing piece
- ⑦ The sensor's ultra-wide strap fixing groove.

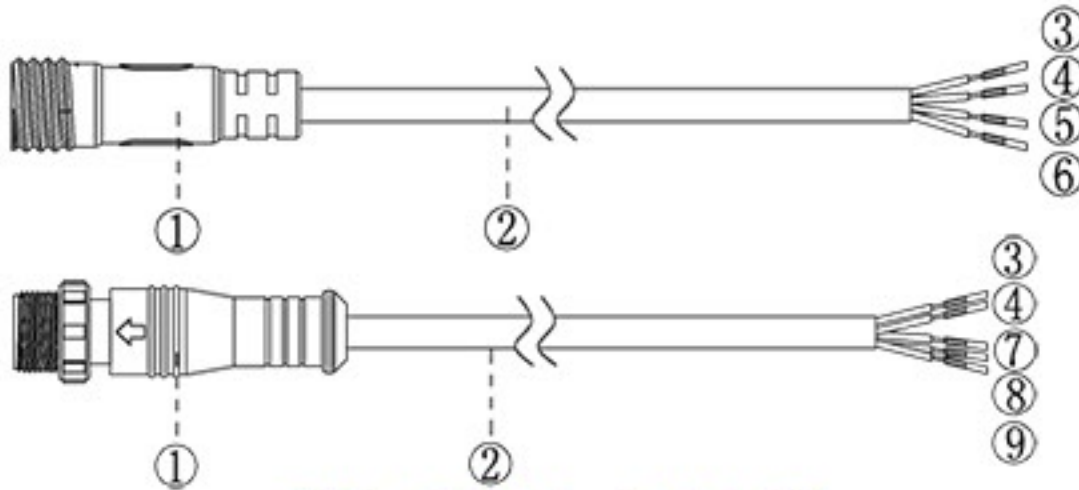

Picture 3 Signal extended cable

- ① Signal wire connection plug.
- ② 4-core signal line or 5-core signal line, standard wiring length is 7 meters.
- ③ Red core wire for sensor power supply(Positive).
- ④ Black core wire for sensor power supply(Negative).
- ⑤ 4-core green wire, sensor signal wire, marked as RS232-RX/RS485-A.
- ⑥ 4-core yellow wire, sensor signal wire, identified as RS232-TX/RS485-B.
- ⑦ 5-core green wire, sensor analog voltage 0~5V output wire.
- ⑧ 5-core yellow wire, sensor TTL-UART TX signal output wire.
- ⑨ 5-core blue wire, sensor TTL-UART RX signal receiving wire.